



PLAYER'S OPTION™: Combat & Tactics

Advanced Dungeons & Dragons® Rulebook



Advanced Dungeons & Dragons®

WORLD OF ADVENTURE Rulebook

PLAYER'S OPTION: Combat & Tactics



U.S., CANADA, ASIA,
PACIFIC, & LATIN AMERICA
Wizards of the Coast, Inc.
P.O. Box 707
Renton, WA 98057-0707
+1-206-624-0933



EUROPEAN HEADQUARTERS
Wizards of the Coast, Belgium
P.B. 34
2300 Turnhout
Belgium
+32-14-44-30-44

Visit our website at www.tsr.com

Foreword

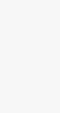

Way back in issue #39 of DRAGON® Magazine, I found a great article called *Good Hits and Bad Misses*. My friends and I had been playing the AD&D® game for a couple of years, and we took one look and adopted the article's critical hit and fumble system. We ignored every piece of advice about responsible use of the system and began using the critical tables in our next game.

Our epic battles turned into bloodbaths. Our group of adventurers left a trail of dismemberment and sucking chest wounds in our wake. I distinctly recall one battle in which my character, a dwarven fighter named Hendel, had the unbelievable misfortune of losing one leg, an arm, and the other leg at the ankle. He still had 30 hit points left, so Hendel kept on battling, swinging his axe with great war-cries as he crawled along after his enemies. Talk about your suspended disbelief!

Now it occurs to me that maybe, just maybe, even Conan (or Godzilla!) would have been incapacitated by these injuries. In fact, maybe Hendel, if role-played well, would have curled up into a ball and cried for his mother when he lost that first leg. I sure would have. But we had a great time with it, even when fumbles led to friendly-fire decapitations and other such incidents.

The point to all this is that any fantasy role-playing game has a pretty tough job in creating fast but semi-realistic combat rules, and the AD&D game, even with variant rules like the critical hit system we ran amok with, is basically an abstract game. The *Combat & Tactics* book is a compromise that adds some detail to combat—not to make it more *realistic*, but to make combat more *believable*. There are darn good reasons why people stop fighting after they lose a couple of limbs, why 12th-level fighters don't turn their backs on guys with knives in their hands, and why people ought to be polite to angry folks pointing loaded crossbows at them.

If you're one of those players who thinks, "Hey, it's only 1d4 points of damage, what do I care?" (and who hasn't, once in a while?) you'll find that this book's going to make you think twice. I can't think of a single example in all of fantasy literature where a character wasn't concerned about someone trying to put a knife or arrow in him; why should your character be any different? *Combat & Tactics* rewards common sense and quick thinking. Taking needless risks and making bad decisions can get a person killed in a fight. Don't you think your character would see things the same way?



Rich Baker
November, 1994

Before anyone ever thought about creating a role-playing game, there was a little set of rules called the CHAINMAIL™ game. With that slim booklet in hand, one could use miniature figures to conduct medieval battles, from sweeping conflicts in which huge armies of steel-clad men fought for honor and booty, to small bands of heroes storming formidable castles, to forces of elves taking up their bows against fearsome dragons.

The CHAINMAIL rules were hardly the last word in historical accuracy, but they were easy to learn and easy to play. They also did a great job of conveying what it might have been like to see a medieval battle unfolding before you. The CHAINMAIL game eventually gave rise to the first fantasy campaigns, but a set of miniatures rules is not a role-playing game, and it wasn't long before the D&D® game, and later the AD&D game, came along to replace it. Nevertheless, the CHAINMAIL rules for tabletop combat remain at the root of the AD&D game.

The AD&D game is about more than combat, but what fantasy adventure is complete without at least one pitched battle where the heroes prevail by the strength of their sword arms and the sharpness of their wits? The *Combat & Tactics* book is for anyone whose heart races (as mine does) at the thought of clashing arms; not just hack 'n slash, but heroic battles with swirling action, ringing steel, and eldritch flashes of magic. You won't find 20 pages of tables telling you exactly where a sword blow lands in this book, but you will find plenty of ways to make combat more than a dice-rolling contest or an exercise in subtracting hit points from your character's total. If along the way you learn to stay away from fights unless you're sure your party can win them, that's even better.



Skip Williams
November, 1994

Table of Contents



Chapter One:		
PLAYER'S OPTION™ Combat System6		
Does This Belong in My Campaign?6	Dexterity14	Moving Through Other Figures
The Battle Map7	Encumbrance14	in Combat22
Figures and Facing7	Simplified Encumbrance15	Overruns22
Scale8	Opening the Battle15	Choosing an Action23
Melee Scale8	Surprise15	The Actions24
Range8	Encounter Distance16	Attack24
Weapons8	Set-up16	Cast a Spell24
Monsters8	The Five Basic Steps	Charge24
Missile Scale9	of Every Combat Round16	Cover25
Switching Scale10	Step One: Monster Action	Fire/Throw Missiles25
Combined Scale10	Determination17	Guard26
The Combat Round10	Step Two:	Move26
Combat Rounds and	Player Action Declaration17	Parry27
Game Time10	Step Three: Initiative17	Run27
Spell Durations10	Step Four: Resolution of Actions17	Sprint27
Combat Status10	Step Five:	Unarmed Combat27
Clear11	End of Round Resolution17	Use A Magical Item27
Threatened11	Initiative17	Withdraw27
Unusual Monsters	The Initiative Roll17	Ending the Combat Round28
and Threatening12	Base Initiative18	Retreats28
Grappled12	Weapon Speeds18	Fatigue28
Attacks of Opportunity13	Critical Events18	Keeping Track of Fatigue28
Movement13	Combat Actions19	Effects of Fatigue28
Base Movement13	Combat Actions and Movement20	Recovering from Fatigue28
Exceptional Abilities	No-Move Actions20	Effects of Force Marching
and Movement14	Half-Move Actions20	on Fatigue29
Strength14	Full-move Actions20	Morale29
	Movement and Initiative21	Informal Morale Checks29
	Combat Movement	Formal Morale Checks29
	on the Battle Map22	Failing a Morale Check29

Credits

Design: L. Richard Baker III & Skip Williams

Editing: Thomas M. Reid

Project Coordinator: Steve Winter

Art Coordinator: Peggy Cooper

Cover Illustration: Jeff Easley

Interior Illustrations: Doug Chaffee, Les Dorscheid, Larry Elmore, Ken & Charles Frank, Roger Loveless, Erik Olson, and Alan Pollack

Graphics Coordinator: Paul Jaquays

Graphic Design: Dee Barnett

Production: Paul Hanchette

Typography: Angelika Lokotz

Photography: Charles Kohl

Diagrams: Paul Hanchette

Special Thanks: Dave Gross

ADVANCED DUNGEONS & DRAGONS, DUNGEONS & DRAGONS, AD&D, D&D, DUNGEON MASTER, DRAGON STRIKE, and DRAGON are registered trademarks owned by TSR, Inc. CHAINMAIL, MONSTROUS MANUAL, PLANESCAPE, PLAYER'S OPTION, and the TSR logo are trademarks owned by TSR, Inc.

This book is protected under the copyright laws of the United States of America. Any reproduction or other unauthorized use of the material or artwork contained herein is prohibited without the express written permission of TSR, Inc.

Random House and its affiliate companies have worldwide distribution rights in the book trade for English language products of TSR, Inc. Distributed to toy and hobby trade by regional distributors.

©1995 TSR, Inc. All Rights Reserved. Printed in the U.S.A.

Table of Contents

Status	29
Special Combat Conditions	29
Standard and Optional AD&D Rules	29
Movement and Footing	30
Cover and Concealment	30
Mounts	30
Rear or Flank Attacks	30
Sitting, Kneeling, and Lying Prone	30
Damage and Dying	31
Weapon Type vs. Armor Type	31
Firing Into a Melee	31
Additional Rules	31
Higher Ground	31
Knockdowns	31
Critical Hits	32
The Gray Areas	32
Example of Combat	32
Round One	33
Round Two	35
Round Three	37
Round Four	37

Chapter Two: Combat Options38

Does This Belong in My Campaign?	38
Battle Tactics	39
Shield Wall	39
Versus Missiles	39
Versus Melee	39
Spear Hedges	40
Mounted Charge	40
Archery from Horseback	41
Attack Options	42
The Opposed Roll	42
Block	42
Called Shot	42
Disarm	43
Grab	44
Overbear	44
Pull/Trip	45
Sap	46
Shield-Punch	46
Shield-Rush	46
Special Weapon Maneuver	47
Trap	47
Trap and Break	47
Unarmed Attack	47
Unhorse	49
Fighting Styles	49
Single Weapon	49
Two-handed Weapon	49
Size and Two-handed Weapons	49
One- or Two-handed Weapons	49
One-handed Weapons used Two-handed	49
Weapon and Shield	50
Two Weapon	50
Unarmed	50

Missile or Thrown Weapon	50
Multiple Loaded Weapons	50
Thrown Weapons	50
Weapon-Specific Styles	50
Dueling	51
What's A Duel?	51
Initiative	51
The Dueling Plot	51
Attacking in the Right Spot	51
Reading an Opponent's Move	53
Moving the Figures	53
Choice of Defense	53
Choice of Attack	53
Ending a Duel	54
Heroic Frays	54

Chapter Three: The Battlefield56

Does This Belong in My Campaign?	56
Battlefields	57
The Four Basic Battlefields	57
Dungeons or Caves	57
Town or Building	57
Outside	57
Castles or Fortifications	57
Battlefield Characteristics	57
Encounter Range	57
Lines of Fire	58
Cover and Concealment	58
Footing	58
Obstacles	58
Unusual Materials or Hazards	58
Terrain Types	58
Badlands	58
Caves	59
Desert	59
Fields or Farmland	59
Forest, Heavy or Jungle	59
Forest, Light	60
Hills	60
Marsh	60
Mountains	60
Plains	61
Ships	61
Swamp	62
Taverns	62
Town Streets	62
Generating a Battlefield	62
Step One: Scale	63
Step Two: Topography	63
Flat	64
Hilly	64
Broken	64
Slopes and Escarpments	64
Step Three: Ground Cover and Water	64
Clear	64
Thickets	64
Light Woods	64
Heavy Woods	64
Clear	64
Bog	64

Stream	64
Pond	64
Step Four: Obstacles	65
Step Five: Putting It All Together	65
Fighting in Unusual Conditions	65
Limited Visibility	65
Moonlight or Moderate Fog or Rain	65
Starlight or Dense Fog or Heavy Rain	65
Total Darkness	65
Water	65
Weapon Restrictions	65
Vision	65
Movement	66
Fighting Underwater Monsters	66
From the Surface	66
Climbing	66
Movement	66
Fighting	66
Fighting Flying Creatures	66
Aerial Combat	66
Initiative	66
Threatening	66
Movement	66
Attacks from Below	67
Attacks from Above	67
Unseating a Rider	67
Combat on Other Planes	67
Astral Combat	67
Ethereal Combat	68
The Effects of Magic on the Battlefield	68
Wizard Spells	68
Priest Spells	69
Magical Items	69

Chapter Four: Weapon Specialization & Mastery70

Weapon Proficiencies	70
Intelligence and Proficiencies	71
Proficiencies and the	71
Weapon Groups	71
Specialization and	71
Weapon Groups	71
Character Classes and Weapon Proficiencies	71
Kits and Barred Weapons	72
New Weapons	72
Shield Proficiency	72
Armor Proficiency	72
Weapon Mastery	72
Nonproficiency	72
Familiarity	73
Proficiency	74
Expertise	74
Specialization	74
Melee Weapons	74
Missile Weapons	74
Bows	74
Crossbows	74

Table of Contents



Firearms	75
Weapon Mastery	75
Effects of Mastery	75
High Mastery	75
Grand Mastery	76
Special DM Note	76
Fighting Style Specializations	76
Weapon and Shield Style	76
One-handed Weapon Style	76
Two-handed Weapon Style	77
Two-Weapon Style	77
Missile or Thrown Weapon Style	78
Horse Archers	78
Local Fighting Styles	78
Special Talents	78

Chapter Five:

Unarmed Combat82

Does This Belong in My Campaign?	82
Brawling	83
Brawling Attacks Against	
Armed Opponents	83
Temporary Damage	83
Opposed Rolls	83
Pummeling	83
Pummeling Procedures	84
Pummeling Skill Levels	84
An Example of Pummeling	85
Special Pummeling Maneuvers	86
Sapping	86
Kicking	86
Wrestling	86
Wrestling Procedures	87
Holds	87
Previously Established Holds	
and Locks	87
Breaking Free	88
Assistance	88
Locks	88
Wrestler Versus Wrestler	89
Wrestling Skill Levels	89
An Example of Wrestling	90
Overbearing	91
Overbearing Procedures	91
Pins	91
Effects of Pins	91
Maintaining and Breaking Pins	92
Assistance	92
Overbearing Skill Levels	92
An Example of Overbearing	92
Attack Options and	
Unarmed Attacks	93
Subdual Attacks	94
An Example of Subduing	94
Martial Arts	95
Martial Arts Procedures	95
Martial Arts Skill Levels	95
Martial Arts Weapons	96
An Example of Martial Arts	
Combat	97
Martial Arts Talents	97

Chapter Six:

Critical Hits100

Does This Belong in My Campaign?	100
Critical Hits: System I	101
Critical Hits: System II	101
Critical Hit Charts	102
Location	103
Severity	103
Resistance	103
Reading the Critical Hit Tables	103
Specific Injuries	103
Critical Hit Effects	105
Critical Hit Tables	107–115

Chapter Seven:

Weapons & Armor116

Equipment Groups	117
Reading the Equipment Lists	117
Stone Age or Savage Cultures	117
Tools/Common	118
The Bronze Age	
and Ancient Cultures	118
Roman	119
Dark Ages	120
The Crusades	121
Hundred Years' War	123
The Renaissance	123
Middle Eastern	126
Oriental	126
Firearms	126
Armor	127
Master Weapon List	128
Weapon Descriptions	129
Weapons Tables	130–133
Weapon Groups	145
Weapons and Ability Bonuses	146
Armor Descriptions	146

Chapter Eight:

Siege Warfare152

Does This Belong in My Campaign?	152
War Machines	153
Bombardment Engines	153
Ballista	154
Bombard	154
Cannon	154
Catapult	155
Trebuchet	155
Bombardment Engine	
Procedures	155
Indirect Fire Engines	155
An Example of Indirect	
Bombardment	157
Direct Fire Engines	159
An Example of Direct	
Bombardment	160
Vehicles	160
Chariot	160
Howdah	162

Carrying Capacities For Beasts	163
Wagon	163
Driving Checks	
and Flipping Over	164
Ramming	164
Miscellaneous War Machines	165
Battering Ram	165
Bore	165
Cauldron	165
Gallery Shed	166
Greek Fire Projector	166
Mantlet/Abatis	166
Ram Catcher	167
Rocks	167
Critical Hits and	
Knockdown Dice	167
Multiple Targets	167
Siege Tower	167
Escalades	168
The Approach of A Castle	168
Walls	168
Wall Defenses	168
Scaling Walls	168
Ladders	169
Grappling Hooks	169
War Machine vs. War Machine	169
Fires	169
Sapping	171
Petards	171
Creatures Inside	
Destroyed Targets	171
Magical Attacks	171
Sieges	173
Reduction	173
Reduction Procedures	173
Saving Throw Failure	173
Mines	174
Counter Mining	174
Investment	175
Mass Combat	175
Mass Combat Procedures	175
An Example of Mass Combat	176
Proficiencies	177

Chapter Nine:

Monsters178

Does This Belong in My Campaign?	178
Creatures in Battle	179
Intelligence	179
Alignment	180
Morale	180
Creature Types	181
Humanoid	181
Animal	182
Monster	182
Attack and Armor Types	187
Attacks	187
Armor	187

Index189

Chapter One: PLAYER'S OPTION™ Combat System



This chapter introduces the PLAYER'S OPTION combat system, an advanced set of skirmish rules designed to add detail and flavor to battles in an AD&D game. The combat rules from the *Player's Handbook* and *DUNGEON MASTER® Guide* have been expanded and streamlined to create more active, exciting battles.

In most forms of personal combat, there is a lot more going on than a cycle of swing-and-miss and swing-and-hit actions. In a fight, people move around. They press advantages or fall back when they need to get some room. Consider a pair of boxers. They're not just throwing punches; they're ducking, dodging, weaving, and trying different attack strategies such as jabs, hooks, or uppercuts.

Armed combat is much the same. Position is important. Enemies try to surround lone characters to get flank or rear attacks. Large creatures such as giants or dragons use their bulk to knock smaller opponents back and scatter defenses. These are not unusual attacks or special maneuvers; they're things that just *happen* in the chaos of a fight.

The PLAYER'S OPTION combat system incorporates these effects and tactics, making them available for heroes and monsters both. Your battles will never be the same again.

Does This Belong in My Campaign?

The PLAYER'S OPTION combat system is an integrated set of rules that dovetails with the later chapters in this book. However, you don't have to use this chapter in order to make use of the other systems.

This chapter presents several new combat actions, restructures the AD&D initiative system, and introduces retreats, fatigue, and critical events. Most of the material assumes that you will use these rules with character and monster miniatures on some kind of map. If you don't want to run combat like this, you'll still find that the new initiative system and actions can be used without any figures or maps at all.

Combat System

The Battle Map

The PLAYER'S OPTION combat system is played on a gridded battle map with 1-inch squares. The battle map becomes a diagram of the battlefield that can be used with figures, stand-up counters, or markers. The exact location of each character or creature is important, since facing and terrain are critical to the tactics of a fight.

A number of games and accessories, such as the DUNGEONS & DRAGONS® Adventure Packs, include gridded maps. Feel free to borrow mapboards and modify them for use in your own campaign.

You can also use dry-erase boards, magnetic dungeon tiles, or washable gridded mats to portray your battlefield. You can make your own maps to customize the battlefield for each combat. In fact, it's a good idea for the DM to prepare for an encounter by making a map of the battlefield beforehand. As long as the map is marked in 1-inch squares, it will do.

Some DMs and players may prefer battle maps marked with hexes instead of squares. Hexes, however, introduce certain inconveniences to the rules that do not surface with a square grid. (For example, can figures occupy partial hexes near walls?) Nevertheless, with a few modifications it is certainly possible to adapt the PLAYER'S OPTION combat system to a hex grid.

Figures and Facing

Every character in a fight is represented by a miniature, stand-up, or marker of some kind. Figures show the location of every creature in the battle and also show the *facing* of each creature. In melee scale, one Man-sized creature fills one square on the map.

In any fight, facing is very important. It's hard to punch someone standing behind you unless you turn around. Each figure or marker on the battle map should have an obvious front facing. For miniatures in strange poses, everyone should agree beforehand what direction is the front of figure. "This figure faces the square his sword is pointing at" is good enough.

All figures have *front*, *flank*, and *rear* spaces. The three spaces in front of a figure are its front spaces, the two spaces directly beside it are flank spaces, and the three spaces behind it are rear spaces. Facings can be at the side of a square or at the corner (see diagram).

Normally, characters can only attack enemies in their front spaces and gain attack bonuses when they attack an enemy's flank or rear.

There are two situations where more than one figure

can occupy a single square: grappled figures are both in the defender's square, and characters in *close order* (see Chapter Two) can fit two figures to a single square. If there is more than one figure in a square, each figure has the same front, flank, and rear spaces; no one is considered to be in the left side of the space, or the back of the space, or whatever.

Tiny (Size T) creatures can fit an unlimited number in one square, although it would be unusual for more than 10 to be in one space unless they were insect-sized.

Figures that are smaller than Man-sized (Size S) normally occupy one square each, but if space is tight they'll fight two to a square with no penalty. Small creatures in close order can fit three figures in a square.

Large (size L) creatures normally occupy one space on the map. They can fight in close order simply by occupying adjacent spaces.

Huge (size H) creatures occupy two to four spaces on the map, depending on their size and shape. Humanoids such as giants and ettins are two squares wide, creating an extra front space and an extra rear space. Horse-like or serpentine creatures have a narrow front and a long body, creating two extra flank spaces. Block-like or massive creatures occupy a four-space square.

Gargantuan (Size G) creatures occupy at least six spaces. They can be even bigger if the DM decides that the creature's proportions are truly immense. A dragon with a 40-foot body could take up a block of spaces two wide and eight long! Gargantuan creatures define front, flank, and rear spaces so that roughly one-third of the adjacent squares fall into each category.

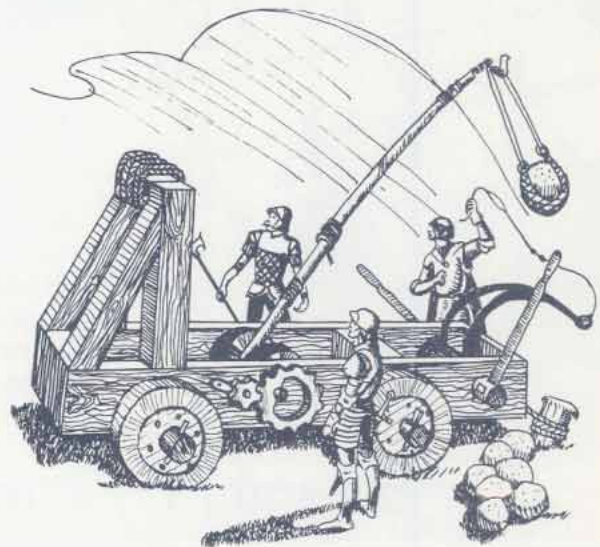

Chapter One



Scale In normal combat situations, each 1-inch square on the map represents an area 5 feet square. This is referred to as melee scale. Under certain special circumstances, each 1-inch square can represent 5 yards. This is known as missile scale.

Melee Scale

The melee scale is the default scale for battles that take place indoors, inside dungeons, in darkness or fog, or at close range. As long as the combatants are all starting within 50 or 60 yards of each other, most battle maps are big enough to run in melee scale from the start. This will save you the trouble of converting from missile scale to melee scale during the battle (see Missile Scale, below).

In melee scale, remember that spell and missile ranges are based on yards, not feet. A thrown dagger normally has a short range of 10 yards, or 30 feet. In melee scale, this is 6 squares on the battle map. A spell with a 30-yard range can be targeted 18 squares away.

Range

Most characters and monsters can only make melee attacks against creatures standing in one of their front spaces. However, some weapons provide extra reach for characters, and some monsters cover a greater area because of size.

Weapons

Many polearms are assigned a range, much like missile weapons. A polearm with a range of 2 can strike enemies standing in the character's front square or any adjacent square beyond the row of front squares.

Some weapons are defined as *range only* weapons. Pikes and lances fall into this category. These weapons can be used to make normal attacks in the squares they can reach but cannot be used against targets in between the wielder and the weapon's point.

Creatures wielding range 2 or larger weapons or natural attack forms cannot make melee attacks through an occupied square to another square unless as part of a spear or pike hedge (see Chapter Two).

Monsters

Any Large creature armed with a weapon adds 1 to its range, due to its great natural reach. For example, an ogre wielding a spear (normally range 1) has a range of 2 with the weapon. Any Huge creature armed with a weapon adds 2 to the weapon's range. A Gargantuan creature adds 3 to a weapon's range; a titan swinging a 15-foot sword endangers an enemy quite a ways off.

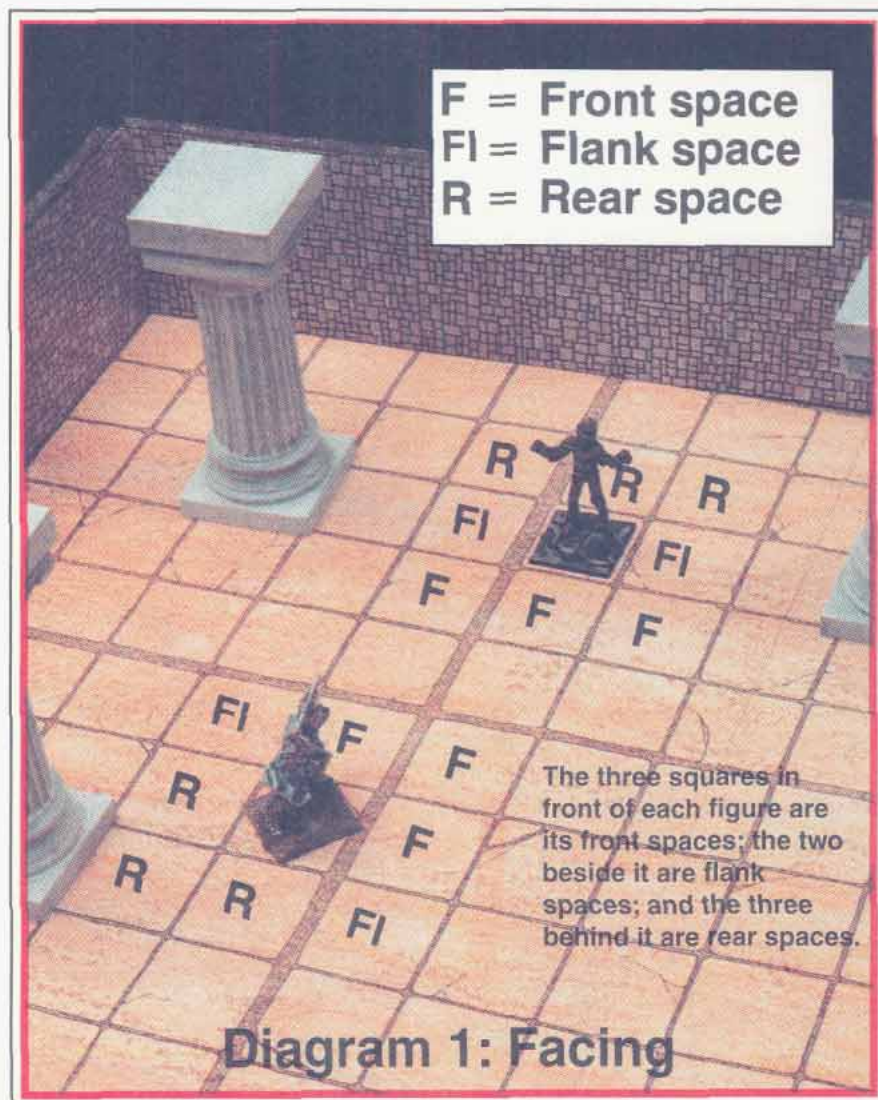

Combat System



Some monsters may also have natural attacks that allow them to strike opponents at ranges greater than 1.

Missile Scale

Some battles may open in missile scale, which is five yards to the square. The only reason to set up a battle in missile scale is when the two hostile forces try to engage each other with spells or missiles at ranges greater than 50 yards or so. Naturally, this usually happens in outdoor settings with good visibility. If neither side has any missile or spell capability, there is no reason to set up the battle in missile scale. Save yourself the trouble of converting and set it up in melee scale from the start.

For example, the heroes encounter a party of orcs while climbing a high mountain pass. The DM decides that the two groups spot each other at a range of 500 yards, since there isn't much cover. Nothing happens until the groups close to 210 yards, since that is the maximum range of the party's longbows. The DM tells the players that they begin the battle in missile scale, 42 squares away from the orcs.

In missile scale, characters and monsters move $\frac{1}{5}$ as fast as normal. A character that could normally move 12 squares in a combat round can only move four spaces per round in missile scale. There are nine melee squares in a single missile square, so up to nine Man-sized creatures can occupy a square when missile scale is in effect.

Diagram 2: Facing of Larger Creatures

F = Front space
FI = Flank space
R = Rear space

The larger figures shown here have extra front, flank, and rear spaces since they occupy more spaces on the map.



Chapter One



Since all spell and missile weapon ranges are expressed in yards, it is easy to figure ranges in missile scale. A target eight squares away is actually 40 yards distant.

Switching Scale

When two opposing creatures move adjacent to each other, it's time to switch the scale from missile to melee scale. Select one figure as an anchor, and move all the other figures three times as far from the anchor as they were. In effect, you're zooming in on the battle.

An easier but less accurate method of zooming in on the battle is to simply announce that you're switching scale and allow both players and monsters to get a second set-up. As long as everyone sticks by the spirit of the set-up, just eyeball it. Make certain that the opposing forces have three times as many squares between them as they did before the scale was zoomed in.

Combined Scale

A handy way to keep track of where the party members are in relation to each other is to have them set up their marching order in melee scale. Set up the monster group in melee scale in relation to each other. Now, assume that all the spaces between the party and the monsters are missile squares. Make sure you indicate where the scale changes by setting a pencil or ruler on the map.

This combined scale method assures that monsters trying to close under missile fire have to withstand the normal amount of attacks before they get close enough for melee. It's also useful for determining the areas of effect of any spells cast at the opposing group. When any two opposing characters come in contact, switch the scale.

The Combat Round In a standard AD&D game, rounds are assumed to be about one minute long. The combat system round lasts about 10 to 15 seconds, during which a typical swordsman will make about three to six swings. Most characters and monsters can only make one effective attack in this time; the rest of the swings are feints, parries, or just for show.

Higher-level characters with multiple attacks are able to make more of these swings count. Parries are followed up with ripostes. Feints suddenly become attacks

when an opening presents itself. With time and practice, a skillful swordsman can make every swing of his sword a potentially lethal attack.

Combat Rounds and Game Time

Combat rounds *replace* the one-minute round in normal AD&D combat situations. If you need to keep count, five combat rounds equal one normal round, and 50 equal a full turn.

To make things easy, the DM can rule that a battle, regardless of its actual length, takes one turn. Characters tend to spend several minutes checking on fallen enemies, surveying their own injuries, and making sure that the enemy has abandoned the field before dropping their guard. Unless time is an issue, this is reasonable.

Spell Durations

All spells with durations expressed in rounds last for the exact same number of combat rounds. Spells with durations measured in turns last for the entire battle. If a spell measured in rounds is in the middle of its duration when the fighting begins, the balance of its duration runs in combat rounds.

For example, a 5th-level mage casts a haste spell that lasts three rounds, plus one round per level, for a total of eight rounds. In the fifth round, the party gets into a fight. The haste spell lasts four combat rounds before expiring.

Everything else about the spell still functions on a round-by-round basis, as it did before. A cleric casting *heat metal* still inflicts 2d4 points of searing damage in the third, fourth, and fifth combat rounds. A wizard with a *feather fall* spell still falls at a rate of 120 feet per combat round. Remember, this is an abstract system; applying physics properties to every situation (such as the fact that the wizard with *feather fall* is now plummeting to the ground at a hasty 6.8 mph rather than the standard 1.4 mph) may reveal lots of facts, but it won't make for a better game.

Combat Status Any figure involved in combat falls into one of three categories: *clear*, *threatened*, or *grappled*. This represents the immediacy of an enemy threat and influences what actions the character can choose for

Combat System



that combat round. A character's options are extremely limited when he is caught in an owlbear's hug.

In addition to governing the character's choice of combat actions for the round, threatening is also important because it determines who is subject to what are known as *attacks of opportunity* (see below).

Clear

Characters who are standing free of the melee and aren't endangered by any adjacent monsters are considered clear. (The character can still be attacked by missile fire, charged, or have a spell thrown at him, of course.) As long as a character is not in the threatened spaces of any enemy figure, he is clear. The character's choice of combat action is unrestricted.

Characters who are clear are allowed to turn to threaten a figure that moves up to them in the course of a combat round. The character doesn't have to do this; he can ignore the danger. The character only gets this free facing change once per round, so he can elect to threaten the first figure that moves up to him or to wait upon the arrival of a more dangerous enemy.

Threatened

Any square that a creature can reach with its weapons or claws also *threatens* those squares and therefore any characters or creatures standing in one of the threatened squares. The character's own facing doesn't matter—it's possible to be threatened by someone standing behind you.

Diagram 3: Combined Scale

The shaded squares are in missile scale. Note the dice that have been used to mark the borders between missile scale and melee scale.



Chapter One

Threatened characters can choose to ignore the creature threatening them and take any combat action they wish, but if they do, the threatening creature gains an immediate attack of opportunity. The following actions create an attack of opportunity for the threatening creature:

- Attempting missile combat (other than at the threatening creature, and only in the combat round when it first threatens the character).
- Moving away from the threatening creature. This includes move, charge, and run, but not withdraw.
- Turning so that the threatening creature is now in a rear square.
- Attempting an unarmed attack against any foe except an unarmed human-like creature.

Monsters and characters threaten all eligible squares throughout the entire round. If a character tries to sprint through the threatened squares to get by the defender, the defender gets an attack of opportunity as the character runs by. If the creature being attacked suffers from a successful knockdown roll or if a critical hit from the attack of opportunity is suffered, then it must stop moving. Otherwise, it may run by the creature threatening it.

Unusual Monsters and Threatening

There are a number of creatures that do not have a clear front facing. Who can tell what the dangerous end of an ochre jelly or otyugh is? These amorphous monsters don't have rear or flank spaces, and therefore threaten any character who moves next to them.

Grappled

Grappled characters are physically restrained by their foes. There are a number of ways to grapple with an opponent; wrestling, martial holds, pinning, and grabbing are all possible. In addition, some monsters have special attacks that grapple their victims. For example, a giant scorpion can pin its prey in its claws, or an owlbear can hug a victim.

Grappled creatures *must* get free before they can move. The only combat actions a grappled creature can take are:

- Respond with unarmed combat.
- Attack the grappling creature with a size S weapon.
- Attempt to escape. Each grappling method defines a means of escape.

Grappling creatures occupy the same square on the battle map, unless there is something unusual about the monster doing the grappling. For example, a roper can grapple characters up to 10 squares away with its special tentacle attack.

Grappling figures never threaten other squares.

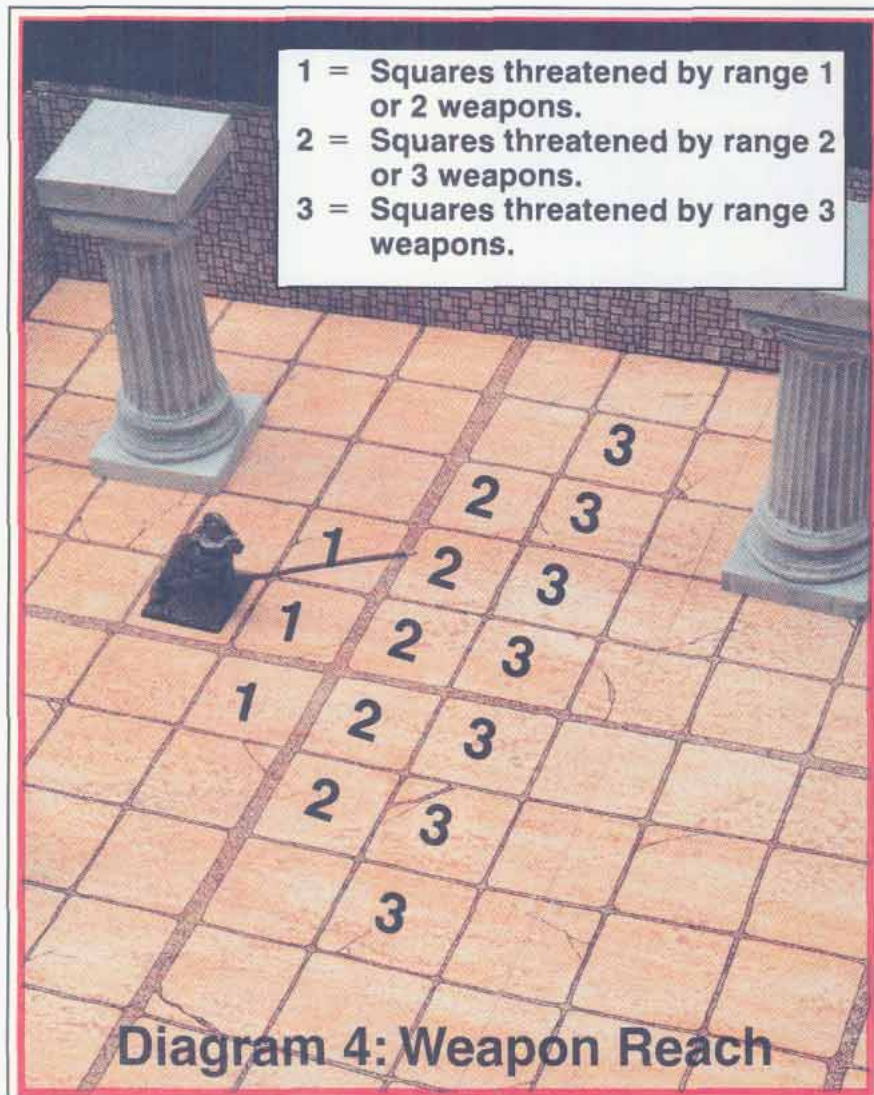

Combat System



Attacks of Opportunity

Attacks of opportunity occur when a threatened character or creature ignores the enemy next to it or turns its back on a foe. The threatening enemy gets to make an immediate melee attack (or sequence of attacks for monsters with multiple attacks) against the threatened creature. Attacks of opportunity cannot be performed with missile weapons. This is a free attack that does not take the place of any actions the threatening creature had already planned.

A creature can't make more than one attack of opportunity against a single opponent in the course of a combat round, but if several enemies leave themselves open, the creature can make one free attack against each one.

There is a limit to the number of attacks of opportunity a single creature may make in one round. Warriors and monsters can make three attacks of opportunity plus one per five levels or Hit Dice. All other characters can make one attack of opportunity plus one per five levels. Thirty kobolds trying to swarm past a fighter in a narrow passage will take losses, but some will still get through.

Surprised characters and monsters cannot make attacks of opportunity during the round in which they are surprised.

Movement Obviously, movement is an important part of a fight. If a character is wielding a sword, he can't hurt anyone with it unless he gets very close to them. The more time a character spends moving, the less he is able to do when he gets there.

In the standard AD&D game, every character and monster has a base movement rate. Since **PLAYER'S OPTION** combat rounds are shorter than AD&D rounds, each point of that base movement rate allows a PC, NPC, or creature to move one square per combat round in melee scale. A human fighter with a movement rate of 12 can move 12 squares, or 60 feet, in one combat round. If a character moves diagonally, it costs 3 movement points for each 2 squares, rounded up. If a character moves three squares diagonally, it costs 5 movement points: 3 for the first two squares and 2 for the the third square.

Remember, this is a conservative advance. Figures can exceed their normal movement rates by *charging*, *running*, or *sprinting* (see Attack Options, below). The same human fighter sprints 180 feet in a combat round, which isn't bad for an untrained runner wearing sturdy boots, heavy clothes, and carrying a sword.

Characters determine their combat system movement in three steps:

- Determine the character's base movement rate from his character race;
- Adjust the base movement rate for exceptional ability scores;
- Modify the character's movement due to his encumbrance.

Base Movement

Every character (and monster) begins with a base movement determined by race. For monsters, this information appears in the appropriate *MONSTROUS MANUAL*™ accessory under Movement. For characters, the base move varies by race:

Character Race	Movement Rate
Human	12
Elf or Half-elf	12
Dwarf	6
Gnome	6
Halfling	6

Unless the DM wants to generate ability scores for every NPC in the game, it's safe to assume that any generic member of the race has the base movement rate listed. However, player characters and exceptional NPCs may be able to move faster than normal.



Chapter One

Exceptional Abilities and Movement

Characters with exceptional Strength or Dexterity scores can increase their base movement rate beyond the normal limits of their race. Similarly, characters with weaknesses in these areas are slower than others of their kind.

Strength

Add the character's hit probability adjustment to her base movement rate. If you are also playing with the *Skills & Powers* rulebook, add the hit probability adjustment based on the character's Strength/Stamina (not Strength/Muscle) instead.

Dexterity

Add the character's reaction adjustment to his base movement rate. If you are also playing with the *Skills & Powers* rules, use the adjustment for Dexterity/Balance instead.

For example, Loftos the Swift, a human fighter, has a Strength of 17 and a Dexterity of 16. His Strength gives him a hit probability bonus of +1, and his Dexterity gives him a reaction bonus of +1, too. His base movement rate, therefore, is $12+1+1$, or 14.

Encumbrance

Even the fastest sprinter won't move so quickly when he's carrying 140 pounds of armor, weapons, and adventuring gear. A character's encumbrance falls into five categories: *none, light, moderate, heavy, and severe*. Encumbrance is described in the *Player's Handbook* in Chapter 6: Money and Equipment.

To determine the character's encumbrance category, find his Strength and read across the table. The numbers on the table are the breakpoints for each category. A character with a Strength of 14 is not encumbered until he has 56 pounds of gear, lightly encumbered until he has 86 pounds of gear, moderately encumbered until he carries 116 pounds of gear, and heavily encumbered up to a load of 146 pounds.

To calculate a monster's strength for this purpose, add $3\frac{1}{2}$ points per size category (rounded down) to the monster's base Hit Dice (ignoring plusses). Thus, an ogre has a generic Strength score of 18 (Large creature is size category 4, $\times 3\frac{1}{2} = 14$, plus 4 Hit Dice = 18).

**Diagram 5:
Movement**

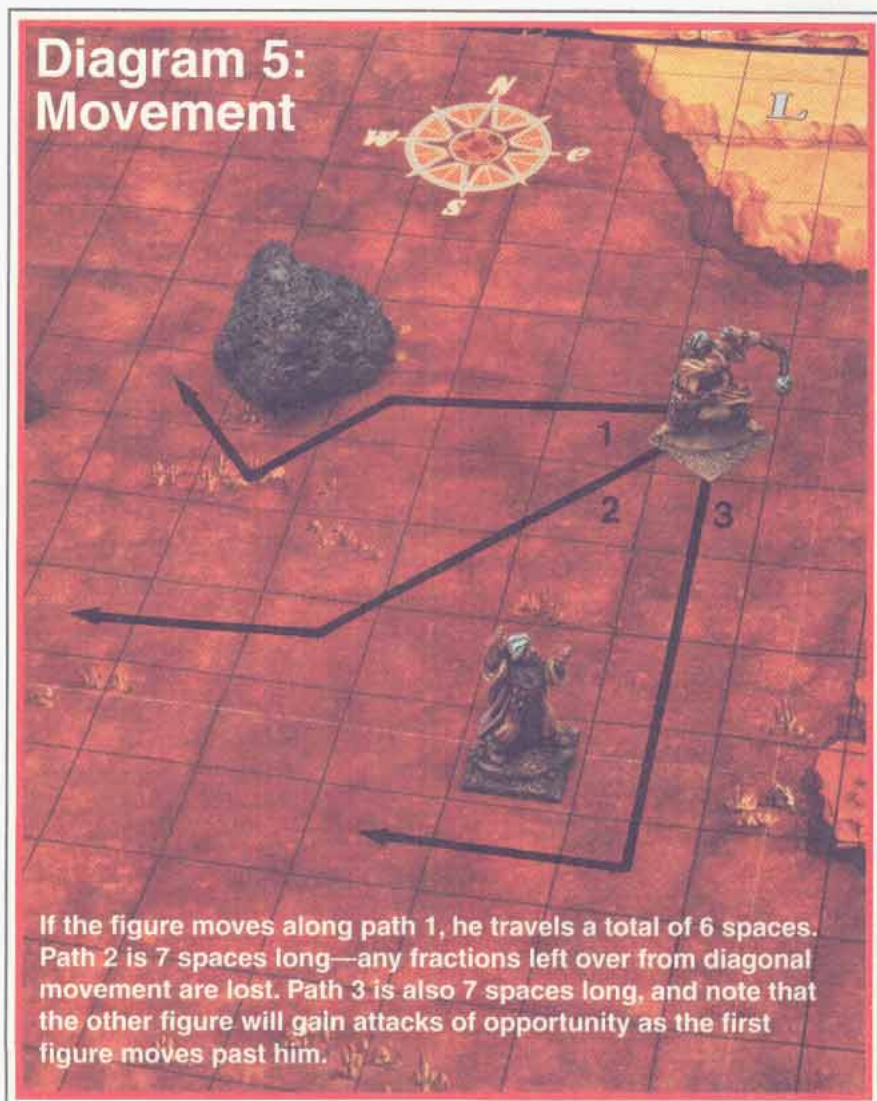

Combat System



Character Strength	Encumbrance Category			
	Lt.	Mod.	Hvy.	Severe
3	6	7	8	10
4-5	11	14	17	20
6-7	21	20	39	47
8-9	36	51	66	81
10-11	41	59	77	97
12-13	46	70	94	118
14-15	56	86	116	146
16	71	101	131	161
17	86	122	158	194
18	111	150	189	228
18/01	136	175	214	253
18/51	161	200	239	278
18/76	186	225	264	303
18/91	236	275	314	353
18/00	336	375	414	453

A creature's final movement is figured by comparing current encumbrance with natural base movement.

Base Move	None	Encumbrance Category			
		Lt.	Mod.	Hvy.	Severe
1	1	1	1	1	1
2	2	2	1	1	1
3	3	2	2	1	1
4	4	3	2	1	1
5	5	4	3	1	1
6	6	4	3	2	1
7	7	5	4	2	1
8	8	6	4	2	1
9	9	7	5	2	1
10	10	7	5	3	1
11	11	8	6	3	1
12	12	9	6	3	1
13	13	10	7	3	1
14	14	11	7	4	1
15	15	12	8	4	1
16	16	12	8	4	1
17	17	13	9	4	1
18	18	14	9	5	1

In addition to affecting how far a character can move in a combat round, encumbrance also affects how well a character can fight. Moderately encumbered characters suffer a -1 penalty to attack rolls. Heavily encumbered characters suffer a -2 attack penalty, and their Armor Class suffers a +1 penalty. If the character is severely encumbered, he suffers a -4 penalty to all attacks and a +3 penalty to his Armor Class. Fatigue may temporarily increase a character's effective encumbrance; see Fatigue for more information.

Simplified Encumbrance

If the standard encumbrance rules aren't worth the trouble, here's an easier way to do it. Most of the weight a character carries is in armor and weapons. To streamline things, only use the character's armor, shield, and largest weapon when figuring the total weight carried. This slightly favors PCs, but it's much faster than tracking every addition of weight.

In Chapter Seven, armor is rated with a base encumbrance. This is the typical encumbrance level of a human wearing that armor. For example, plate mail is rated as moderate encumbrance, with a movement of 6 for a typical human. These default values make it easy to eyeball NPC movement rates.

If you use the simplified encumbrance rule, make sure that it is not abused. If the DM feels that a PC is taking advantage of this rule (for example, carrying dozens of weapons or vast amounts of adventuring gear), he can insist on using the more detailed accounting of the normal encumbrance rules.

Opening the Battle Now that you know what the map looks like, how to handle long- and short-range battles, and how the figures interact on the map, it's time to discuss the set-up and presentation of a fight. What effect does surprise have? Where do terrain features go? Who sets up their figures where?

Surprise

Before a battle begins, one or both sides may have to check for surprise. The Dungeon Master has the final word on whether or not a surprise check applies. There are situations in which one side may have to make a surprise check but their opponents don't—for example, an ambush or a nighttime encounter with enemies carrying bright lights. Surprise conditions and modifiers are

Chapter One



discussed extensively in the *DMG* and the *PHB* (Chapter 11: Encounters for both).

The surprise check is a d10 roll, modified for the surrounding conditions and any special preparations one party or the other makes. Normally, a group is surprised on a roll of 1, 2, or 3. The surprisers get a free round of attacks, movement, or spells against the surprised members of the other group.

Encounter Distance

The distance between two groups is an important part of setting up the battle. The terrain and weather have a great effect on encounter distance; even an eagle-eyed character will have a hard time spotting his enemies in a dense fog or pitch-black night.

The DM can simply assign an encounter distance based on his estimation of the situation, or he can roll on the table below. In many cases, the range of the encounter is obvious; if a party of heroes kicks down a dungeon door and storms a guardroom, it stands to reason that the gnoll warriors are *somewhere* in that room.

Situation	Range (melee scale)
Both groups surprised	1d4 squares
One group surprised	1d6 squares
No surprise:	
Smoke or heavy fog	1d8 squares
Jungle/dense forest	2d10 squares
Light forest	4d6 squares
Scrub/brush/bush	4d12 squares
Grassland/field	10d6 squares
Dungeon/night	Limit of vision
No cover	Long missile range

Note that dungeon or night encounters refer to the vision limits of whoever can see the farthest. If a party of heroes equipped with lanterns can see 30 feet in a dark forest, a hunting party of orcs that can see 60 feet may try to open the battle with a volley of arrow fire out of the darkness.

If a situation arises where there is no real cover or the enemy's approach is detected hundreds of yards away, the encounter should be set up at the maximum range of the longest-range missile weapon in the fight. In this case, it will probably be necessary to begin the battle in missile scale and move to melee scale when the groups close.

Set-up

The last step before starting the fight is setting up the battlefield and the location of the combatants. The DM should first arrange the battlefield; if the fight is taking place in a room inside a dungeon, the DM notes the room's size, shape, and interesting contents before placing any creatures in it. Chapter Three describes battlefields of all kinds in great detail.

If one side has spotted the other without being seen, or has surprised the other group, they can make their opponents set up first and then place their own combatants to take advantage of the situation. (They still have to observe the encounter distance dictated by the DM, though.)

If neither side is surprised, or if other special circumstances exist, the DM can dictate the positions of all characters and monsters at the beginning of the battle. The PCs should be set up in their normal marching order, with any adjustments the DM deems appropriate. Someone had to open the door to the guardroom, after all. The monsters are placed by the DM as she sees fit.

If the DM knows something the players don't, there's no reason she can't keep some figures off the map until the players have reason to spot them. If there's a giant spider on the ceiling and no one looks up, the DM should feel free to spring a fiendish surprise when a character walks under it.

The Five Basic Steps of Every Combat Round

With the exception of two skilled fighters using similar weapons or styles, combat is utter chaos. It's ludicrous to believe that any set of game rules could begin to approach an accurate simulation of fights that range from barroom brawls to fantastic duels between archmages and dragons.

However, there has to be *some* way to resolve combat. In the **PLAYER'S OPTION** combat system, battles are divided into combat rounds, and each round is divided into five basic steps. These steps are:

- Step One: Monster Action Determination
- Step Two: PC Action Declaration
- Step Three: Initiative
- Step Four: Resolution of Actions
- Step Five: End-of-Round Resolution

Combat System



Step One: Monster Action Determination

Before the players announce what their characters are doing this round, the DM secretly decides what actions the monsters take. Once the DM decides what the monsters will do, he should stick by it—he's on his honor not to switch actions after learning the players' decisions. After all, the monsters don't know what the PCs are going to do before they do it. If necessary, the DM can make notes about monster actions to remind himself of what they intend to do.

Generally, monsters and NPCs have the same actions available to them that the player characters do. They can charge, attack, or withdraw, just like the PCs. Monsters normally choose the most advantageous and sensible actions for the situation. Refer to Chapter Nine: Monsters, for more information.

Step Two: Player Action Declaration

After the DM has decided what the monsters will do, each player must announce his character's action for the combat round.

Step Three: Initiative

In this step, all characters in a fight determine when their declared actions actually take place. The **PLAYER'S OPTION** combat system resolves actions in a series of initiative phases, with the resolution time of different actions affected by weapon choice, creature size, and other factors. See Initiative, below, for more information on the initiative system.

Step Four: Resolution of Actions

The declared actions of all characters and monsters are resolved using the initiative phase system. A character can abort his planned action and do something else, but the new action takes place at the very end of the combat round.

Step Five: End-of-Round Resolution

After all actions have been resolved, there are several things that need to be done before the round ends. The four parts of this step are *fatigue*, *retreats*, *morale*, and *status*.

Fatigue is a measure of the character's endurance

over a prolonged combat. At the end of each round, the character checks to see if the combat has lasted long enough for him to become fatigued or exhausted.

Retreats occur when a figure is forced to fall back by the press of the fight. This can have the effect of breaking up an enemy line or forcing the retreating character over a cliff, into quicksand, and so on.

The DM makes morale checks for the monsters, if appropriate. Most creatures don't care to carry a losing battle to their own deaths and will try to break off the fight if things aren't going their way.

Last but not least, characters who are suffering from spell effects, poison, or special critical hits suffer damage or fight off the effect. The exact procedure is determined by the type of condition the character is suffering from.

Initiative Timing is everything in combat. Does a fighter try to get in a quick blow before his enemy can react, or does he wait for a better opening? Who gets to go first when a barbarian warrior is trying to cut down a mage casting a spell? The initiative structure presented here is designed to answer those questions and provide your character with better alternatives for combat.

The Initiative Roll

The **PLAYER'S OPTION** combat system resolves actions in five action phases: *very fast*, *fast*, *average*, *slow*, and *very slow*. A character's action phase is determined by his *base initiative*, modified by his weapon speed and the combat action he selects for the round. Striking at an opponent standing next to you doesn't take much time at all, but running halfway across the battlefield in a long charge will take a little more time.

At the beginning of each round of combat, both sides roll a d10. The side with the lowest roll wins initiative. In each action phase, the side that has won initiative attacks and moves first. In any given action phase for one side of a fight, attacks and spells occur before movement takes place. (In other words, if you and your companion both take an action in the average phase, your buddy gets to fire an arrow or cast a spell down that hallway before you actually begin running down it.) If there are fast creatures on both sides of the fight, the fast creature that won initiative strikes before the fast creature that lost initiative. Fast creatures strike before average creatures, even if the average creature's side won initiative.

Chapter One

Some initiative rolls provide unusual results:

- A roll of 1 accelerates the action phase of that side by one, so a slow character gets to go in the average phase;
- A roll of 10 slows the action phase of that side by one step;
- A tie results in a critical event. Reroll the initiative dice until one side or the other wins, and then consult the Critical Event Table below.

Base Initiative

A creature's base initiative is the time it begins to move or makes an attack if it attacks without weapons. Monsters that normally fight with natural weaponry are simply assigned a base initiative determined by their size and speed.

Monster Size	Base Initiative
Tiny or Small	Very Fast
Man-Sized	Fast
Large	Average
Huge	Slow
Gargantuan	Very Slow

Improve base initiative one grade for a movement rate of 18 or better, and reduce base initiative one grade for a movement rate of 6 or less. Also, moderately encumbered characters and monsters suffer a one-phase initiative penalty, heavily encumbered creatures are slowed by two phases, and severely encumbered creatures suffer a three-phase initiative penalty.

Note that most player characters have a base initiative of fast. Remember, this doesn't take into account weapon speeds or combat actions. Record the character's base initiative on the character sheet—it's used in each and every round of combat.

Weapon Speeds

Characters armed with weapons modify their base initiative with their *weapon speed*. All weapons are assigned a speed rating of fast, average, slow, or very slow. When the character makes an attack, his action phase is his base initiative or weapon speed, *whichever is later*. A fast human armed with a two-handed sword, a slow weapon, attacks in the slow phase of the round. The base initiatives of magical weapons are modified as follows:

Magical Bonus	Base Initiative Modifier
+1	none
+2 or +3	one phase
+4 or more	two phases

Thus, a human wielding a *two-handed sword* +2 gains a one-phase modifier, attacking in the average phase rather than the slow phase.

Critical Events

Strange things happen in the fog of war. Many battles hinge on a lucky break or an unforeseen complication. In the **PLAYER'S OPTION** combat system, this is reflected by the critical event roll.

Critical events are provided to add color and excitement to the melee. They create openings or opportunities that quick-thinking PCs can take advantage of. They also allow the DM to present a more active and visual portrayal of the characters in battle.

The DM is free to rule that the critical event does not occur, or even alter it to reflect the exact circumstances of the battle. For example, if the battle is taking place on a mountainside beneath an overhang of snow, the DM can decide that the critical event is an avalanche triggered by the fighting.

As a general rule, critical events should not directly inflict damage to a character or creature, although they can force saving throw rolls or ability checks to avoid damage. Use critical events to create chaos and disorder on the battlefield, but avoid favoring one side or the other.

Critical Event Table

d20 roll	Result
1–2	Armor Trouble
3–4	Battlefield Damaged
5	Battlefield Shifts
6	Close Quarters
7	Item Damaged
8	Item Dropped
9–11	Knock Down
12	Lucky Break
13	Lucky Opening
14–15	Mount Trouble
16	Reinforcements
17	Retreat
18	Slip
19–20	Weapon Trouble

Chapter One

There are several factors involved in choosing a combat action. It is dangerous to do anything but attack or parry when your character is threatened by an adjacent opponent. It's downright useless to declare a charge when your character is grappled by a giant constrictor snake.

Player characters have the right to choose any action they like in combat, as long as they meet the basic requirements for it. (It makes no sense for a character without magical items to announce that he will use one for his combat action.) However, once the requirements have been met, all options are open. The DM should not disallow a combat action except under the most extreme circumstances. No matter how foolish or difficult something may seem, let the PC try it if he really wants to. (Of course, the DM can assign difficulty modifiers if she deems it necessary.)

The following choices are available as combat actions in the **PLAYER'S OPTION** combat system:

Attack	Fire Missiles	Run
Cast a Spell	Guard	Sprint
Charge	Move	Use a Magical Item
Cover	Parry	

Each of these actions is explained in more detail later in this section.

Combat Actions and Movement

A character's choice of combat action governs how far he can move in a given combat round. For example, a wizard certainly can't move a considerable distance, picking his way through swinging weapons and uneven footing, while attempting to cast a spell, which requires great concentration and precision. Likewise, a warrior cannot safely withdraw from a fight merely by turning and walking away at normal speed. Certain kinds of actions naturally preclude movement, while other choices are actually more effective when larger distances are crossed. Some choices allow for a range of movement options.

The various combat actions fit into three basic movement categories. These categories include no-move actions, half-move actions, and full-move actions. Some of the combat actions listed above may fit into only one category, while others may function with two or even all three types of movement.

No-Move Actions

No-move actions are just that—the character performs some sort of action during her proper action phase, whether it is fighting an opponent or using a wand, without moving significantly during the round. Even if a character chooses any one of the no-move actions, however, she can still adjust her position during her action phase. She can move one square in any direction and choose any facing as a free adjustment to her position. If the character is threatened, she can adjust her position without provoking an attack of opportunity by making sure that her adjustment does not take her out of the enemy's front squares or turn her back to him. No-move actions include:

- Attack
- Cast a Spell
- Cover
- Fire/Throw Missiles (normal ROF)
- Guard
- Parry
- Unarmed Combat
- Use a Magical Item

Half-Move Actions

Half-move actions allow a character to move up to half his normal movement rate and still perform some other action, such as attacking with a weapon or firing missiles. There are, however, limits to what can be done or how far a character can move and still accomplish these actions. Half-move actions include:

- Attack
- Charge
- Fire/Throw Missiles (half the normal ROF)
- Guard
- Unarmed Combat
- Withdraw

Full-move Actions

Full-move actions involve a character moving his full normal movement rate (or even more, in some cases) before attempting other actions. Full-Move actions include:

- Charge
- Move
- Run
- Sprint

Combat System



Armor Trouble

A random combatant has trouble with his armor. Roll 1d6 for the exact problem. The character can remedy the situation by spending one round standing still and repairing his armor.

d6 roll	Result
1–2	Helm lost, victim's head is exposed
3–5	Shield lost
6	Plate lost, +2 to AC (plate armor only)

Battlefield Damaged

Something in or around the battlefield gets broken. If the fight occurs indoors, it might be a piece of furniture, a window, or a keg of ale.

Battlefield Shifts

The tide of battle carries all figures 1d6 squares in a random direction from their current location. Nobody gains any attacks of opportunity.

Close Quarters

Two enemies that threaten each other find themselves inside one another's reach and are effectively grappled.

Item Damaged

A random combatant has something damaged by a wild swing. Choose anything except a weapon and roll an item saving throw to see if it broke.

Item Dropped

As above, but the item is spilled, dropped, or cut free from the owner's person.

Knock Down

A random combatant engaged in melee is knocked to the ground by a collision with someone near him. The nearest figure (friend or foe) must roll a successful saving throw vs. paralyzation or fall down next to him.

Lucky Break

A random combatant is favored by fate and gains a +4 bonus to his Armor Class and saving throws for this round only.

Lucky Opening

A random combatant sees his chance. He gets a +4 bonus to the attack roll against whatever enemy he had planned to attack this round.

Mount Trouble

A random mounted combatant experiences difficulty with his animal. Roll 1d6:

d6 roll	Result
1–3	Mount bolts. It sprints for 1d10 rounds in a random direction or until the rider rolls a successful riding proficiency check.
4–5	Mount rears. The rider must roll a successful riding proficiency check or fall off the mount.
6	Mount falls. The thrown rider must roll a successful saving throw vs. paralyzation or be stunned for 1d6 rounds.

Reinforcements

Allies of the DM's choice show up for one side or the other.

Retreat

The press drives back all threatened figures of one side or the other. See Retreats, below.

Slip

A random combatant slips and falls, spending the round on his back.

Weapon Trouble

A random combatant experiences difficulty with his weapon. Roll 1d6:

d6 roll	Result
1–2	Combatant disarmed unless a successful saving throw vs. paralyzation is rolled.
3–5	Hard parry may break weapon. Roll a successful item saving throw vs. crushing blow to avoid.
6	If the character killed an opponent last round, his weapon is stuck in the foe's body. Take a round to pull it out.

Combat Actions

Combat actions are basic strategies that a character can follow in a round of combat. Does Argath the Brave stand his ground and wait for the orcs to come to him, or does he charge rashly into the center of their line? Does Rowan the Mage cast a spell or spend her round moving to a better vantage point? You decide when you select your character's combat action for that round.

Combat System



Movement and Initiative

Compare these two actions: one character with a readied bow decides to fire at an orc chieftain 40 feet away, and a second character with a readied sword decides to run over to the orc and take a swing at him. Which action is resolved first? Obviously, the archer's attack will arrive before the swordsman gets his swing. Moving takes time, especially in a 10–15 second combat round.

Characters don't instantaneously blink across a battlefield just because it's their turn to move. They begin their move at one point in time and then finish moving sometime later. A character who begins his move when fast actions are resolved may finish his move while average or slow actions are resolved.

Movement always begins in a character's base initiative phase and is performed in half-move increments, one phase at a time. For a half-move action, the total amount of movement takes place in a single phase. For a full-move action, the character moves no more than half of his total movement in each of two consecutive phases, so a sprinting character is actually traveling 1.5 times his full normal movement in each of his two movement phases. After any movement is completed for the character, the rest of the combat action is resolved. Note that an action may be delayed by movement, but it will never occur sooner than normal because of movement. In other words, if a fast character with a two-handed sword (a slow weapon) chooses to make a half-move and attack, the half-move occurs in the fast phase, but the attack does not



Chapter One



happen until the slow phase (unless the character was charging; see below).

Note that when several allies (characters or creatures that all won or lost initiative together) are acting in the same phase, characters performing actions do so before their companions begin to move.

For example, Boldo the swordsman intends to take a half-move and attack an orc, while his companion, Fletcher the Bowman, prepares to fire an arrow at it. If Boldo's half-move and Fletcher's shot both occur in the same phase, the arrow actually streaks toward the orc before the swordsman lunges forward to close with it.

Also note that the 1-square adjustment of a no-move action is considered simultaneous with the action itself. Thus, the adjustment *and* the no-move action all occur before any normal movement is performed by allies who are eligible to do so during the same phase.

Combat Movement on the Battle Map

When a character actually moves across the battlefield, don't pick up the figure and then drop it back down again several spaces away. Trace the exact path the character is following from square to square on the battle map. A character never knows when there is a trap he may trigger or an invisible enemy threatening part of his planned move.

Characters can make any facing changes they want with no cost in movement points during their move. Remember, too, that characters can make a single facing change during an enemy's move if the enemy moves adjacent to them.

Moving Through Other Figures in Combat

A character can move through a square occupied by a friendly figure as long as that figure isn't threatened or attacking in the current round. Enemies can only occupy the same square if they are grappled or if one is prone. Otherwise, larger creatures can attempt to make an *overrun*.

Overruns

When a larger creature attempts to move into a smaller, standing enemy's square, it is called an *overrun*. Mounted figures use their mount's size for this purpose, so a human on a size L horse can overrun a

human on foot. Overruns create an attack of opportunity for the figure being stepped on. After the defender's attack, the defender must roll a successful saving throw vs. paralyzation or be knocked down. Even if he does successfully save, he is forced one square away from his current location. This save is modified by a -4 penalty for a creature two sizes larger than the defender, a -8 penalty for a creature three sizes larger, etc.

For example, a halfling (size S) gets in an ogre's way. After the halfling's attack of opportunity, he must roll a successful saving throw vs. paralyzation or be knocked down. The ogre is two sizes larger, so the saving throw is rolled with a -4 penalty. Even if the halfling successfully saves, he is forced out of the square.

When a defender is knocked down by an overrunning creature, he may suffer a trampling attack. The trampler gets an attack of opportunity that inflicts 1d4 points of damage per difference in size. Even though the defender is prone, no modifiers apply; trampling is an afterthought on the attacker's part. The DM can adjust the damage as he sees fit; very dense creatures such as clay or stone golems may not be seriously hurt by even a giant's trample.

Continuing our example, the halfling fails his saving throw and is knocked flat by the ogre's rush. The ogre gets a free attack of opportunity and rolls a hit. Since there is a two-category difference in size between them, the halfling suffers 2d4 points of damage. Being trampled by someone ten times your weight can be lethal.

A prone creature with an enemy in its square may get up by using a full-move action. Since two standing enemy figures cannot occupy the same square, size always wins; the larger of the two creatures displaces the smaller one. In addition, the standing figure always chooses which square the displaced figure enters. If the creatures are of the same size, an opposed Strength roll is made to determine who stays and who is displaced.

Concluding our example, the halfling decides to rise again to avoid getting trampled some more. Since the ogre is larger than the halfling, the halfling must be displaced one square in order to rise. Since the ogre is also the standing creature, it decides which square the

Combat System



halfling is displaced to. If the roles had been reversed, with the halfling in the square of a prone ogre that wished to stand, the halfling would still have to be displaced, since it is smaller. However, this time the halfling, which is the standing figure, chooses which square to be displaced to.

Of course, the standing figure might wish to keep the other figure from rising, or the prone figure might decide to fight it out rather than try to rise. If one figure wishes to keep another figure prone, an overbearing attack is necessary, but treat the situation as if the attack roll to hit AC 10 is automatically successful (see Overbearing, Chapter Five).

Choosing an Action

When it is time for a character to select an action for the round, the action is chosen independently without selecting a movement category beforehand. For example, if a warrior chooses to attack, there is no need to declare whether this is a no-move attack or a half-move and attack. The player simply announces that his warrior intends to attack.

This allows some flexibility in the system so that the ebb and flow of battle does not thwart the characters' actions each round. By waiting until a character's action phase occurs to determine how much movement is needed to perform a chosen action, much of this problem is eliminated.

Still, there are times when characters may be prevented from completing their action by a change in their situation. A spellcaster may have his spell interrupted, or a fleeing character may find himself trapped with no place to run. When a character's action is prevented by an enemy's interference, the action is lost for the round and the character can take no other action for that round.

On the other hand, characters may sometimes start an action and then think better of it. A character may begin a charge and then pull up short

when he realizes he is about to run into a hedge of pikes, or a character who had planned to fire a crossbow may suddenly recognize his target as a potential ally.

At that point, a character can choose to either hold or abort a combat action when his action phase arises. Holding an action simply involves delaying the intended action for one or more action phases.

For example, Tyar the Glorious wins initiative and declares that he will attack (because there is an orc in front of him). Tyar would normally perform his attack on the average phase, due to his long sword. However, on the fast phase Twillo the Sly, Tyar's thiefling companion, successfully kills the orc with a backstabbing attack. Tyar sees an ogre that will most likely advance during the average phase, but only after Tyar is eligible to take his attack (since Tyar won initiative). Tyar



Chapter One

decides to hold his attack until the slow phase so that he can attack the ogre after it advances.

A character may also choose to abort his planned action in favor of another. There are some limits to the new choice of actions, and the character's turn automatically bounces to immediately after the very slow phase of the combat round. It is treated like an extra phase and is resolved normally in all respects. See the individual action choices for more details.

The Actions

Below are listed each of the actions available to a character and how they are resolved.

Attack

This is the basic action for characters and monsters in a fight. When a character chooses to attack, he makes his normal hand-held weapon attacks. Characters and creatures can make a half-move and attack or they can stand their ground and attack as a no-move action.

Monsters with multiple attacks perform all their attacks on the same phase. If a dragon attacks with average speed, its bite, claws, tail, and wing buffets all take place in the average phase of the combat round. Characters using a weapon in each hand strike in the same fashion, during the action phase of the slower weapon.

Characters who have multiple attacks with the same weapon (such as high-level fighters or weapon specialists) make their first attack normally and then make one attack each phase thereafter until they've resolved all of their multiple attacks. A long sword specialist with two attacks in a round makes his first attack in the average phase and his second in the slow phase of the round.

Normally, a character can combine a move and an attack only by moving first and resolving attacks later. However, a character can choose to attack first and then make a half-move at the end of the round. Note that characters can adjust their position each time they attack, so a hero with multiple attacks could attack several creatures standing apart from each other.

Attacks of opportunity (see Threatening) do not count as a character's attack for the round. It is possible for a creature to get more attacks than normal if its opponent provides it with an opening for an attack of opportunity.

Characters and monsters may choose a number of *attack options*, such as *grab*, *block*, *trap*, or *disarm*. The fighter might use his bill-hook to pull a mounted opponent off his horse, or he might try to trip the animal. He

could even go on the defensive and try to block his enemy's blow. Refer to Attack Options in Chapter Two for more information about the various alternatives.

Cast a Spell

Wizards and priests may choose to cast spells during combat. All spells are assigned an action phase just as weapons are. The character is considered to begin casting in the very fast phase and to finish in the spell's action phase. If the spellcaster is injured by an attack during the casting, the spell is lost.

Spells and spell-like abilities are assigned action phases based on their casting times:

Casting Time	Phase
1-3	Fast
4-6	Average
7-9	Slow
1 round or more	Very Slow

When a character casts a spell, she loses any Dexterity benefit to her Armor Class, since she must hold still and concentrate to make the spell work. After the spell has been cast, the mage or priest may apply her Dexterity bonus to her Armor Class again. If the spellcaster doesn't cast a very slow spell, she can take a half-move at the end of the round.

Psionic powers take effect during a randomly determined phase, regardless of the psionic creature's regular Base Phase.

Random Psionic Initiative

d10 roll*	Base Phase
1-2	Very Fast
3-4	Fast
5-6	Average
7-8	Slow
9-10	Very Slow

*Add the power's Preparation Time to this roll.

Charge

Characters and monsters can charge to rapidly close for combat and make an attack. Charging is a full-move action, but a charging character may move $1\frac{1}{2}$ times his base movement when he charges. A knight with a movement of 6 can charge an enemy up to 9 spaces away.

Characters begin their charge on their base initiative, moving up to one-half the distance of the charge. In the following phase, they move the remainder of the dis-

Combat System



tance. Unlike most attack forms, the charge attack is resolved the moment the attacker arrives. If the knight above has a base initiative of fast and an opponent is standing 7 squares away, the knight moves 5 spaces in the fast phase and 2 more in the average phase, at which point he attacks immediately.

Charging (which might more accurately be called the reckless attack) gives characters several advantages but also imposes some penalties. The charging character gains a +2 bonus on his attack roll. Some weapons, such as lances, are suited for charging and inflict double damage when used in a charge.

Because they are so intent on the attack, however, charging characters are at a disadvantage defensively. They lose all Dexterity bonuses to Armor Class and suffer a +1 penalty to AC in addition to that. Guarding characters with weapons longer than the charger's automatically strike first. In addition, characters can set spears (see Guard) against charges.

Cover

A character with a cocked and loaded crossbow, or an arrow nocked and drawn in a bow, can announce that he is covering an opponent within his weapon's short range. The covering character can only choose to cover a single square on the board, as long as that square is within the weapon's short range and in sight. Only characters with a weapon proficiency slot in bow or crossbow can cover someone in this manner. Covering situations usually are created by the circumstances of the initial encounter; for example, an archer may surprise his enemy, cover him, and order him to drop his weapon. Characters can also declare a combat action to cover someone.

Since the arrow or bolt is ready to be fired, the covering character's first shot is fast (or very fast if the character is a specialist.) See Bows and Crossbows in Chapter Seven. The covering character automatically wins initiative against the covered target. It is possible for a very fast creature to beat out the shot of a proficient archer, but even very fast creatures can be covered by a specialist.

The character can hold his cover until later in the round, if he wants to see what his target is going to do. He can fire first in any later phase. After the first shot has been loosed, the covering character can perform the rest of his missile fire at the regular action phase and rate of fire.

The covering shot itself is made with a +2 bonus to the attack roll. Covering is handy for freezing opponents

in their tracks, since everybody knows how quickly an arrow or bolt can be released once it is drawn.

Covering can also be used with any hand-held bladed weapon—basically, the character puts her sword to an opponent's throat in a single adjacent square and menaces him. The victim must be stunned, dazed, pinned, unconscious, or surprised for a character to cover him with a melee weapon. As with bows and crossbows, the covering character automatically wins initiative against her target and can attack in the fast phase, or in the very fast phase if she is a specialist. The attack is made with a +2 bonus to hit, and the critical number (see Critical Hits in Chapter Six) drops to a 16.

Fire/Throw Missiles

Firing missiles and throwing hand-held weapons (including splashing holy water or oil) is another basic action that is very common in combat. The character can stand still and attack at his full rate of fire, or he can make a half-move and fire or throw missiles at $\frac{1}{2}$ his normal rate.

The one exception to this move-and-fire routine is for missile weapons that have a rate of fire less than 1/round (this includes large crossbows and most firearms). In this case, the character wielding such a weapon can move half his normal rate and still fire the weapon *only on the initial discharge of the weapon*. The weapon is assumed to be loaded and cocked. After this first shot, the character can only fire the weapon as a no-move action.

Firing or throwing missiles is dangerous when a character is threatened by another creature, since it creates an attack of opportunity. The only exception to this rule is during the same combat round that the threatening creature actually moves up to threaten the character. The character can get his shots in while his enemy closes, but after that he had better switch to a melee weapon.

Characters with multiple missile attacks in the same combat round perform their first attack on the normal action phase, and then follow with one missile per phase until they've completed their full rate of fire. For example, a dart specialist has 3 attacks per round with his darts, a fast weapon. He therefore throws his first dart in the fast phase, the second in the average phase, and the third in the slow phase.

Some monsters, such as manticores, may have multiple missiles that are fired simultaneously. These attacks are all resolved in the same phase.

Chapter One

Guard

When a character guards, she waits for her opponents to come to her. Guarding is a half-move action, or a no-move action if the character stands her ground. A guarding character strikes the moment an attacker moves into the guarding character's threatening squares, regardless of her actual initiative and action phase. The only way an enemy can attack a guarding character first is with a longer-ranged weapon.

If a guarding character is attacked by a charging character, the character that won initiative attacks first (unless one of the characters has a longer-ranged weapon than the other). If both the charging and guarding characters have weapons of equal range, then the character with the larger weapon strikes first. Guarding characters are considered to be *set for charge*, and spears and spear-like polearms inflict double damage

against charging creatures (see Chapter Seven).

For example, Aerwen loses initiative and is armed with a long sword, normally a weapon of average speed. A very fast size M creature takes a half-move to attack her with claws in the fast phase, but since Aerwen is guarding, she attacks first. If the very fast creature were charging, it would attack first since it won initiative for the round. If Aerwen had a long spear (range 2), she would get the first blow despite the creature's charge.

If no one attacks a guarding character, she can abort to an attack at the end of the round and take a half-move to reach someone.

Move

Moving allows a character to cover a lot of ground without dropping his defenses. Moving is normally a full-



Combat System



move action, but if a character only moves half his maximum move or less, he can consider it a half-move action instead.

Movement normally begins on a character's base initiative, without modifiers for weapon speed. Each half-move a character makes requires one phase, so a fast character does half his move in the fast phase and finishes his move in the average phase.

Parry

Sometimes the best thing to do is take cover and try not to get clobbered. Any character can choose to parry as a combat action. Parrying is a no-move action that is in effect for the entire combat round. If a character parries, he cannot move, attack, or cast spells.

Parrying reduces a nonwarrior character's Armor Class by one-half his level. A 6th-level wizard with an AC of 5 who parries reduces his AC to 2. Warriors who choose to parry reduce their AC by one-half their level, plus one. A 6th-level fighter gets an AC bonus of 4 by parrying.

Run

A character can double his base movement by running. Running is considered a full-move action; the character can't do anything else in the same combat round that he runs. Running on a battlefield is dangerous; the character loses all Dexterity bonuses to his Armor Class and suffers a +1 AC penalty on top of that. In addition, he is considered to be charging if he runs into a square threatened by an opponent with a set spear.

Characters can maintain a run as long as they have the necessary fatigue points (see *Fatigue*, below). Outside of combat, they can run for a number of rounds equal to their Constitution score. After that, they must stop and rest. See *Jogging and Running in the Player's Handbook* under Chapter 14: Time and Movement for more information.

Sprint

A character can triple his base movement by sprinting. Like running, sprinting is a full-move action that drops the character's defenses for the round.

Unarmed Combat

Any character may choose to make an unarmed attack instead of attacking with his weapons. There are four basic types of unarmed combat: punching, wrestling, overbearing, and martial arts. Refer to Chapter Five for more information on resolving unarmed attacks.

A character can perform an unarmed attack on his base initiative if he doesn't have to move to reach his target, or he can take a half-move action to close for combat. Attacking armed opponents (including monsters with natural attacks) is dangerous for an unarmed fighter; if the character attacks an armed creature that is threatening him, he suffers an immediate attack of opportunity from his intended victim. The armed defender gains a +4 bonus on his attack roll *and* his damage roll against an unarmed attacker.

Monsters with natural weaponry almost never make unarmed attacks. However, it is possible for intelligent creatures to "pull in their claws" and try to batter a character into unconsciousness. Monsters without natural attacks may resort to unarmed combat if they are disarmed or want to capture their enemy.

Use A Magical Item

Generally, a character can use a magical item as a fast action or make a half-move and use an item as an average action. Some magical items take more or less time, as noted below:

Item	Phase
Potion	Average
Scroll	Very Slow
Rod, Staff, or Wand	Fast
Miscellaneous Magical Item	Average

For most magical items with functions that do not emulate combat or spellcasting actions, the magic of the item is activated during the resolution step at the end of the round. In a few cases where powers take an unusual amount of time to activate, the DM is the final arbiter. If an item combines weapon-like characteristics and miscellaneous magic, such as a *rod of lordly might*, it should be treated as a weapon when being used to attack and as a magical item when its other functions are being used.

Withdraw

Withdrawing is the only safe way to leave a square that is threatened by an opponent. When a character withdraws, he backs carefully away from his opponent without turning his back or creating an attack of opportunity for his opponent.

Withdrawing is a half-move that takes place on the character's base initiative. A withdrawing character cannot attack or cast spells, although he can still get attacks of opportunity.

Chapter One

Ending the Combat Round

After all the combat actions have been resolved, it is time to finish up the round and get ready for the next one. The end of the round is a time to take care of any loose ends or bookkeeping that needs to be looked after. The four major items that are addressed at the end of the round are *retreats*, *fatigue*, *morale*, and *status*.

Retreats

When one character inflicts melee damage (but not as a result of missile combat) on an enemy without being hit in return, she may force her foe to retreat, driving him back with well-aimed blows. The attacker doesn't have to force her enemy back; she can decide to let him stand fast and not press the advantage. A defender can ignore the requirement to retreat if he is 4 or more levels/Hit Dice higher than the attacker or if he is two sizes larger than the attacker. A retreat cannot occur if the enemy was knocked down during the round.

When a character retreats, he must move backward into one of his rear spaces chosen by the attacker. If there is no place to retreat directly behind him, the attacker must choose one of the retreating character's flank spaces. If the character is unable to retreat into any rear or flank space, he must roll a successful saving throw vs. paralyzation or be knocked down in the space he is in. In some special situations, the DM may allow a retreating character a chance to avoid being forced back. This allows a character with his back to a cliff (for example) to avoid giving ground.

The creature who forces a retreat may follow her retreating enemy, keeping her foe in a threatened square. The attacker can instead choose to back her enemy off and then hold her own position.

Retreats are good for breaking up enemy battlelines or for maneuvering an enemy into a battlefield hazard. Retreats can also be used to disengage from a threatening creature by driving it back. Retreats don't create attacks of opportunity for the creature forcing the retreat; this is the end of the combat round and everyone is finished attacking for the round. However, the retreating creature may have been pushed into a situation where his rear or flank is exposed to an enemy during the next round of combat.

Fatigue

Fighting a prolonged battle can be exhausting. Only the most heroic characters can stand fast against wave after wave of foes without tiring. The various character classes gain a number of fatigue points equal to their base Hit Die value. In other words, a warrior has 10 fatigue points, a thief 6, etc. Warriors gain one additional fatigue point each time they gain a level; nonwarriors gain one fatigue point every two levels. This value is modified by the hit-point bonus or penalty for Constitution.

For monsters, fatigue points are equal to 8 (since monsters use a d8 for their Hit Dice) plus the number of Hit Dice, rounded down. Thus an ogre (4+1 Hit Dice) has 12 fatigue points.

Keeping Track of Fatigue

Characters and monsters start off in a *fresh* state. In every phase that a character or monster moves or attacks, check off one fatigue point. When the total reaches 0, the character or creature is *fatigued*. Reset the fatigue score back to its original value and check off *two* points in every phase that movement or combat takes place. When the score reaches 0 again, the creature is *exhausted*.

Effects of Fatigue

Characters and monsters who are fatigued move and fight as if they were encumbered one category more than they really are. For example, A character who was moderately encumbered becomes heavily encumbered when he is fatigued.

Exhausted characters move and fight as if they were encumbered two categories more than normal. An exhausted, moderately encumbered character moves and fights as if he were severely encumbered. Usually, exhausted characters are well-advised to catch their breath.

Recovering from Fatigue

If a character or monster spends one round resting, making no moves or attacks of any kind, he gets the chance to recover one category of fatigue (exhausted to fatigued, fatigued to fresh) by rolling a successful saving throw vs. paralyzation. Characters modify the die roll by a cumulative +1 bonus for each consecutive round they spend resting. The character's hit-point bonus for exceptional Constitution is also used as a modifier to the recovery roll.

When a character recovers a fatigue category, his fatigue number is re-set all the way back to its original value. He gets a second wind and can rejoin the fray.

Combat System



Effects of Force Marching on Fatigue

Whenever characters have failed a Constitution check as a result of force marching and are still in the process of recovering (see the *PHB*, Chapter 14: Time and Movement, under Cross-Country Movement), they automatically begin the combat in a fatigued state rather than fresh. Fatigue points are consumed at the doubled rate and all the penalties for being fatigued (as well as the penalties for force marching) apply, until a state of exhaustion is reached. Furthermore, creatures cannot return to a fully fresh state during the battle; only the noncombat recovery period for force marching can remove this restriction.

Morale

The end of the round is also the time for morale checks. Remember, player characters never need to check morale; they're smart enough to know when to cut and run, and foolish enough not to run when they should. However, NPC allies or followers of the PCs may decide to abandon them if things go poorly.

Morale is discussed at length in the *DUNGEON MASTER Guide*, so it won't be reiterated here. The DM is not required to make a morale roll every round; he can use his own judgment to decide when someone might be thinking of calling it a day. Some good guidelines of when monsters or NPCs might make morale checks:

- When surprised;
- When faced by an obviously superior enemy force;
- When an ally is slain by magic;
- When 25% of their group has fallen;
- When 50% of their group has fallen;
- When their leader deserts or is killed;
- When they are fighting an enemy that can't be hurt by their weapons;
- When they are offered a chance to surrender and they've already met one other condition for a morale check.

Informal Morale Checks

The DM can always just decide if a creature or NPC passes its morale check, without even rolling dice. The DM should be fair with this; it'll quickly annoy the players if their trusted henchmen run away through DM capriciousness at the first sign of trouble.

Formal Morale Checks

A formal morale check is a comparison of a 2d10 roll against the creature's base Morale rating, modified for the situation. An extensive list of modifiers appear on the DM Screen and under Morale in Chapter 9: Combat in the *DUNGEON MASTER Guide*.

Failing a Morale Check

When a character or group of monsters fails a morale check, their first consideration is to get away from the fight. If they fail by a small margin (say, 1 or 2 on the die roll), they try to withdraw in good order. If they fail by a large margin, they break off the fight and flee for their lives. Intelligent creatures may try to surrender if there is no place for them to run, or if they think they won't be able to get away.

Status

This is a catch-all phrase for any condition or situation that may affect the actions next round. Did a character get knocked down during the fight? He'll start the next round prone. Generally, magical effects and continuing damage (poison, burning, acid, etc.) actually inflict their damage in this part of the combat round.

Special Combat Conditions

There are a number of special situations that can arise in the course of a fight, through natural circumstances or military planning. Someone might fall down or be incapacitated by a spell. A battle fought in a thick, tangled forest may limit archery to shots of 30 feet or less. Stinging snowstorms or sandstorms may limit visibility and carry away light missiles. The side that considers the characteristics of the battlefield in its tactics often gains an advantage over its enemies. Chapter Three describes battlefields in great detail, but there are a few special rules that should be mentioned here.

Standard and Optional AD&D Rules

These rules can all be found in the *Player's Handbook* and/or the *DUNGEON MASTER Guide*. Even if they are listed as optional rules in the core rule books, they are a standard part of the *PLAYER'S OPTION* combat system. They are presented again here (with any necessary combat system alterations and additions) for ease of reference. Refer to Chapter 9: Combat in the *PHB* and *DMG* for more details.

Chapter One



Movement and Footing

Ground characteristics may drastically limit a character's ability to move in a fight. The movement reductions listed below apply to the character's base movement, so a character with a normal move of 12 spaces would be reduced to a move of four spaces in heavy brush. If a character passes through multiple ground types in one round, he uses the worst of the modifiers.

Condition	Reduce Move by
Heavy brush or thicket	$\frac{3}{4}$
Light brush or forest	$\frac{1}{2}$
Ice or slippery footing	$\frac{1}{2}$
Steep slope or rough ground	$\frac{1}{2}$
Knee-deep snow, water, or soft sand	$\frac{1}{2}$
Waist-deep snow or water	$\frac{1}{2}$
Shoulder-deep snow or water	$\frac{3}{4}$

Cover and Concealment

Concealment and cover work only against missile fire, and cover also provides a bonus to saving throw rolls where an effect causes physical damage, like a *fireball* spell.

The amount of the target that is concealed or covered determines the penalty to any missile attacks made against the target.

Target is:	Cover	Concealment
25% hidden	-2	-1
50% hidden	-4	-2
75% hidden	-7	-3
90% hidden	-10	-4

A target is impossible to hit when it is completely blocked from the archer by cover.

Line of Fire. A figure's line of fire is considered to run from the center of its square to the center of the target's square. If the line of fire passes through any part of a square containing an obstacle, the target is considered to be covered or concealed to some extent. The DM can decide whether the target is 25%, 50%, 75%, or 90% screened, or he can roll randomly if it is not clear. If the line of fire passes through a square containing a figure engaged in melee, the archer must use the rules for firing into a melee to determine where his shot goes.

Note that intelligent creatures who are facing the archer will usually use the screening object for its maxi-

mum effect, while animals and monsters that aren't intelligent (Int 1 or less) will rarely try to screen themselves against an archer's fire.

If there's any question about which squares the line of fire passes through, you can use a string, a ruler, or the edge of a card to check the missile's path.

Mounts

Mounts provide their rider with a +1 bonus to attack rolls when fighting against unmounted opponents, while the opponents suffer a -1 penalty to attacks against the rider (there is no penalty to attack the mount itself). Most mounts are fairly large and can overrun smaller creatures. A normal human on horseback can use his mount's speed and size to trample his opponents underfoot (see *Overrun*). Many mounts are also capable of making attacks along with their rider.

Rear or Flank Attacks

If a creature is able to position itself for a rear or flank attack, it gains a significant advantage. Flank attacks get a +1 bonus to hit, and rear attacks a +2 bonus. A thief attacking from the rear can declare a *backstab* and gain a +4 bonus to his attack roll. In addition to the attacker advantages, the defender's shield doesn't help against flank attacks on his unshielded side nor on *any* rear attacks. Last but not least, the defender's Dexterity adjustment doesn't count against rear attacks, since the defender can't see the attack coming and attempt to dodge it.

Sitting, Kneeling, and Lying Prone

Characters may sit, kneel, or fall prone as a no-move action. Getting up from sitting or kneeling is considered a half-move action, so a character can stand and still fire a missile or make an attack. Standing up from a prone position is treated as a full-move action, so the character can do nothing else in that round except rise.

Sitting or kneeling characters are slightly harder to hit with missiles or thrown weapons; they gain an Armor Class bonus of -1 against any ranged attacks. However, they're at a disadvantage in melee. Anyone making a melee attack against a sitting or kneeling character gains a +2 bonus to hit them.

Prone characters present very small missile targets and gain an AC bonus of -2 versus ranged attacks. However, they are very vulnerable to anyone close enough to threaten them. Melee attacks against prone characters gain a +4 bonus to hit.

Combat System



Kneeling characters can use any weapon with no penalty. Sitting characters can only use crossbows without a penalty; with any other weapon, they suffer a -2 penalty to their attack rolls. (Note that characters on horseback are mounted, not sitting!) Prone characters can only use crossbows or size S weapons while they're on the ground. A prone character firing a crossbow attacks at one-half the normal rate of fire and makes any melee attacks with a -4 penalty to hit.

Damage and Dying

Creatures reduced to negative hit points are incapacitated and begin losing 1 hit point per round until they reach -10, at which point they die. A creature's loss of hit points can be halted by binding its wounds, using the healing proficiency, or casting some kind of curative magic on the victim.

Characters who have been reduced to 0 hit points or less are helpless; they can't tend their own wounds or take any actions. At exactly 0 hit points, the character is simply unconscious, and remains so until healed or until 2d6 full turns pass. If a character's death is prevented by binding his wounds or healing him, the character is completely helpless for at least 24 hours.

It is dangerous to leave characters at a negative hit point total for long. Each day that a character begins with negative hit points, roll a d10 and compare it with the absolute value of the character's hit points (in other words, take into account only the numerical value of the hit points, ignoring the negative sign). If the die roll is less than this numerical score, the character loses 1d4 additional hit points. This additional loss of hit points can be avoided if someone with the healing proficiency is there to tend to the patient, or if curative magic is used.

For example, Gorathan the Unlucky was badly mauled by a dire wolf and reduced to -5 hit points. His companions bound his wounds, but no clerics or proficient healers were nearby, so Gorathan didn't recover any hit points. The next day, a d10 is rolled to see if he worsens or not. If the roll is a 4 or less (which is less than the "5" of Gorathan's -5 hit points), Gorathan loses 1d4 additional hit points. If the roll is a 5 or better, Gorathan recovers hit points normally for a day of bed rest. If Gorathan has some bad rolls, he might not make it.

Weapon Type vs. Armor Type

Some weapons have an innate advantage against certain types of armor. In the Middle Ages, hundreds of

weapons were designed for the purpose of penetrating heavy armor. Weapon types and armor types are explored in more detail in Chapter Seven.

Firing Into a Melee

Throughout the ages, friendly fire has been a significant threat on the battlefield. In the PLAYER'S OPTION combat system, the shorter combat round means that archers can't wait to pick and choose their shots. They have to fire or hold their fire in an instant.

A melee is defined as any situation in which one creature threatens another. Firing or throwing missiles at either of the two engaged creatures requires the shooter to roll to see which figure he actually attacks. All creatures that are threatened or threatening one another in the same group are included, so the archer is guaranteed of at least firing at the right engagement.

To determine the actual target, assign each Man-sized target 1 point on a die. Small-sized targets get ½ a point, Large targets 2 points, Huge targets 4 points, and Gargantuan targets 6 points.

Additional Rules

These rules are specific to the PLAYER'S OPTION combat system.

Higher Ground

If the attacker's waist is higher than his opponent's head, he gains a +1 bonus to his attack rolls. Stairways, tabletops, and steep slopes may create higher-ground opportunities for a character in combat. This doesn't apply to colossal creatures such as giants who are fighting on level ground against much shorter characters, nor does it apply to mounted characters; they already get a bonus.

Knockdowns

Some creatures can smash their opponents to the ground with raw strength or heavy weaponry. Knockdowns are based on the size of the attacker's weapon compared to the size of the defender.

Every weapon (including monster attacks) is assigned a *knockdown die* that is rolled when a hit is scored. Light weapons have a small die, while heavy weapons use a d10 or d12 for knockdowns. The size of the target determines what roll is required for a knockdown.

Chapter One



Target Size	Knockdown Roll
T	3
S	5
M	7
L	9
H	11

Don't confuse the knockdown die with the actual damage caused by the hit; they are two different things. It is a little quicker to roll the knockdown chance along with the damage dice, but don't feel like you have to.

Obviously, some creatures are immune to knockdowns. An ochre jelly, black pudding, or fire elemental can't really be knocked down, nor could a crocodile or shark in the water. In addition, some monsters may be unusually resistant to knockdown effects.

Knockdown Effects. Creatures who suffer a knockdown must roll a successful saving throw vs. death or be knocked prone. The victim can stand up by forfeiting a half-move or an attack. If he has already completed his actions for the round, he has to wait until next round to stand up. Refer to Sitting, Kneeling, and Prone above for more information about being on the ground.

Any character or creature armed with a loaded and cocked crossbow or firearm that is knocked down must roll a successful saving throw vs. paralyzation or accidentally fire the weapon.

Monsters and Knockdowns. Monsters who wield weapons can use the knockdown die size that is listed for that weapon, and then modify the die for their own size. Increase the die one step for each Size category larger than Man-sized, or decrease it for each one under. For example, an ogre is wielding a morningstar, which normally has a knockdown die of d10. Because the ogre is Size L, one size larger than Man-sized, the knockdown die increases to a d12.

For monsters with natural attacks, choose a weapon that seems close to the attack type and then modify it for the monster's size. An adult dragon's claws may be like long swords. A wyvern's sting might be similar to a spear. Monsters may resist knockdowns better if they have four or more legs, are exceptionally dense or low-built, or seem generally tougher than normal.

Critical Hits

Although critical hits are mentioned in the core AD&D rules as an option, this system works differently than any provided there. A critical hit may occur when a

character rolls exceptionally well during his attack. The attack roll must be a natural 18 or higher, and the roll must hit the target by at least 5. A 1st-level fighter with a THACO of 20 can achieve a critical against an opponent with AC 5, since he can roll a 20 and hit him with 5 to spare, but he can't get a critical against an opponent with AC 4 (or better).

As a basic rule, critical hits inflict double damage. However, Chapter Six is devoted to the topic of critical hits and presents an integrated system that accounts for the strength of the blow, the location injured, and a dash of luck.

If PCs can get critical hits with great attack rolls, monsters should be able to as well. Otherwise, the balance of the game shifts in favor of the player characters.

The Gray Areas

Opponents who are facing off across squares that are partially blocked by solid obstacles may or may not be able to effectively attack one another. For example, two opponents are facing each other diagonally where a wall corner abutts the intersection of their squares. Half of the people using the PLAYER'S OPTION combat system will argue that they can attack each other, and half of them will argue against it. The same problem arises when considering whether or not figures can occupy half squares (like any square that is bisected by a diagonal wall). Some people will argue for such a rule, and some will argue against it.

The answer to these and other similar gray areas of figure placement and movement is, it doesn't really matter, as long as the solution is equitable. If characters *can* attack around corners, then so can monsters. If you don't want it to happen, then it doesn't—for characters or monsters. Neither choice skews the system to favor anyone, so both solutions are equally viable. Just decide as a group beforehand how you want to handle the situation, then stick with it. These kinds of situations and conditions are way too numerous to mention or adjudicate within these pages, but the guidelines set out above should give the DM and players enough to work with.

Example of Combat

Here's the scenario: four adventurers are exploring the dungeons beneath a ruined temple when they encounter a guardroom with six bugbears armed with morningstars. The heroes are Dain, a dwarf fighter with 13 fatigue points; Pascal, a human paladin with 10 fatigue points; Lyssa, an elven

Combat System



mage with 4 fatigue points; and Damiar, a half-elven thief with 6 fatigue points. The bugbears each have 11 fatigue points (Monsters get 8 points plus their Hit Dice, in this case 3+1). None of the members of either group are considered encumbered.

No one is surprised, so the DM places the bugbears in their room and tells the players to arrange their heroes in the doorway. Since Damiar opened the door, the DM decides that Damiar must be in front, even though Dain usually takes point in the marching order.

Round One

First, the DM decides what the bugbears are going to do. The two on the flanks move to take cover, the one in the middle flips the table for cover, his companions

close for combat, and the last bugbear is still getting out of bed and decides to wait and see what happens. Now the DM asks each of the players what their characters will do:

Damiar: "I'll shoot at the nearest bugbear."

Pascal: "Bugbears? We can take them. I'll close for an attack!"

Lyssa: "I'll throw a sleep spell."

Dain: "There might be more of 'em around. I'll cover the hallway with my crossbow."

Everyone has declared an action, so it's time to roll initiative. The DM rolls a 5, but the players beat him with a roll of 3. Now, the DM begins with very fast actions and starts working through the round.

Diagram 6

Opening Positions

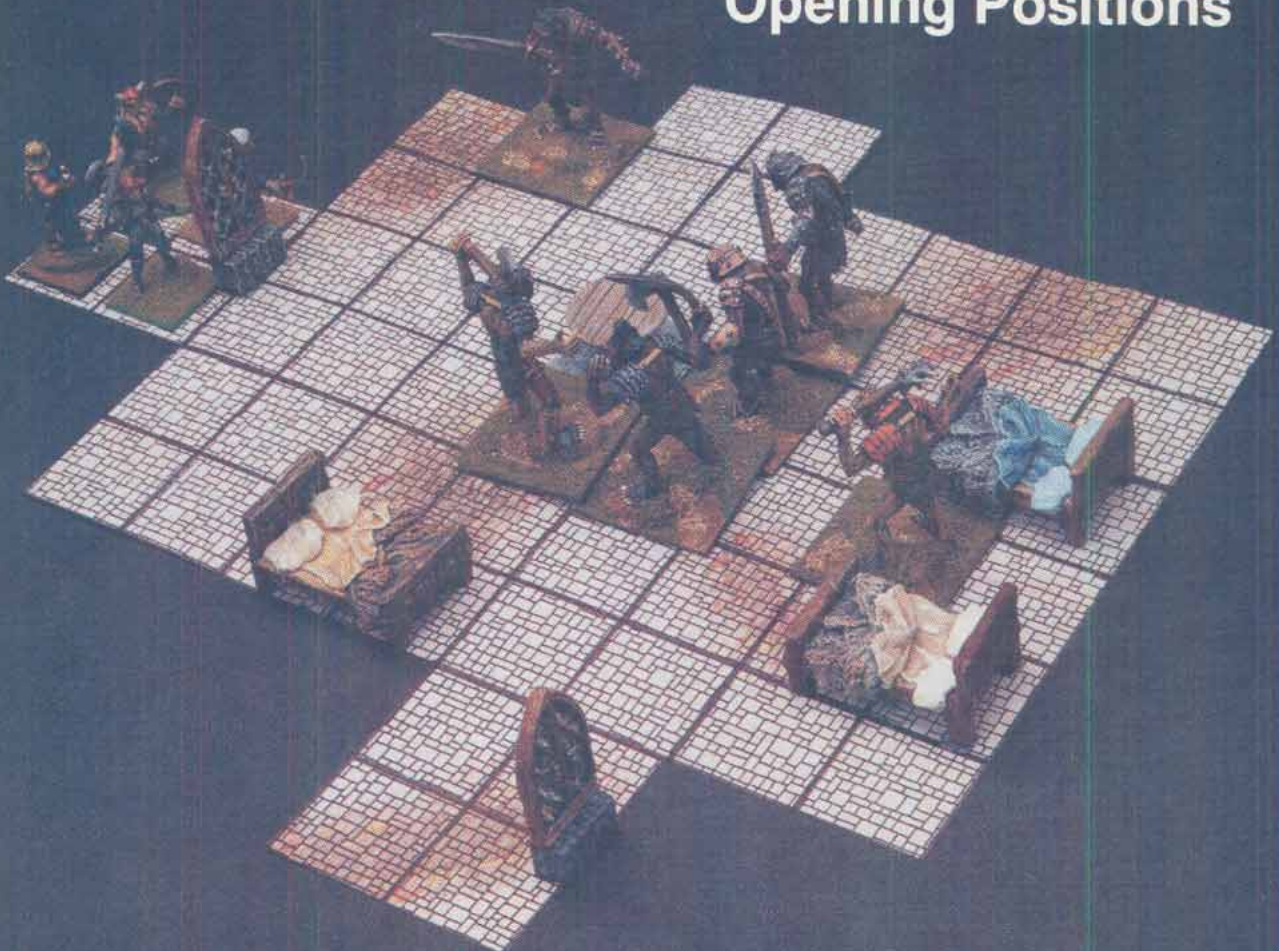

Chapter One

DM: "Okay, nobody's very fast this round. You guys won initiative, so who's fast?"

Lyssa: "My sleep spell's fast."

Pascal: "I start moving."

DM: "Where do you want to center your spell, Lyssa?"

Damiar: "Don't catch us with it!"

Lyssa: "I'll center it on the bugbear in the middle of the room." (Rolls effect) "My spell affects 5 Hit Dice of bugbears."

DM: "Sorry, that's only one. He's out."

Pascal: "I'm moving! I'll jump on the table in front of them."

DM: "No problem. You threaten the bugbear, and he threatens you. Don't forget to mark a fatigue point off. That's it for fast. Let's go on to average actions."

The bugbear's base initiative is average, but the players won initiative and get to resolve their average actions first. Pascal is wielding an average-speed long sword.

Damiar: "My first bowshot is average. I rolled a 20! Is that a critical hit?"

Damiar's adjusted THACO with his longbow is a 16, so he hit an AC -4 with his roll of 20. The bugbears are only AC 5, so he easily hits the bugbear with a good enough roll to critically hit the monster. The basic critical rule is double damage dice, but the DM could use the critical hit rules in Chapter Six if he wanted to. With doubled damage, Damiar rolls 2d8 for his sheaf arrow and tags the bugbear for 15 points of damage, dropping it with one shot!

Diagram 7

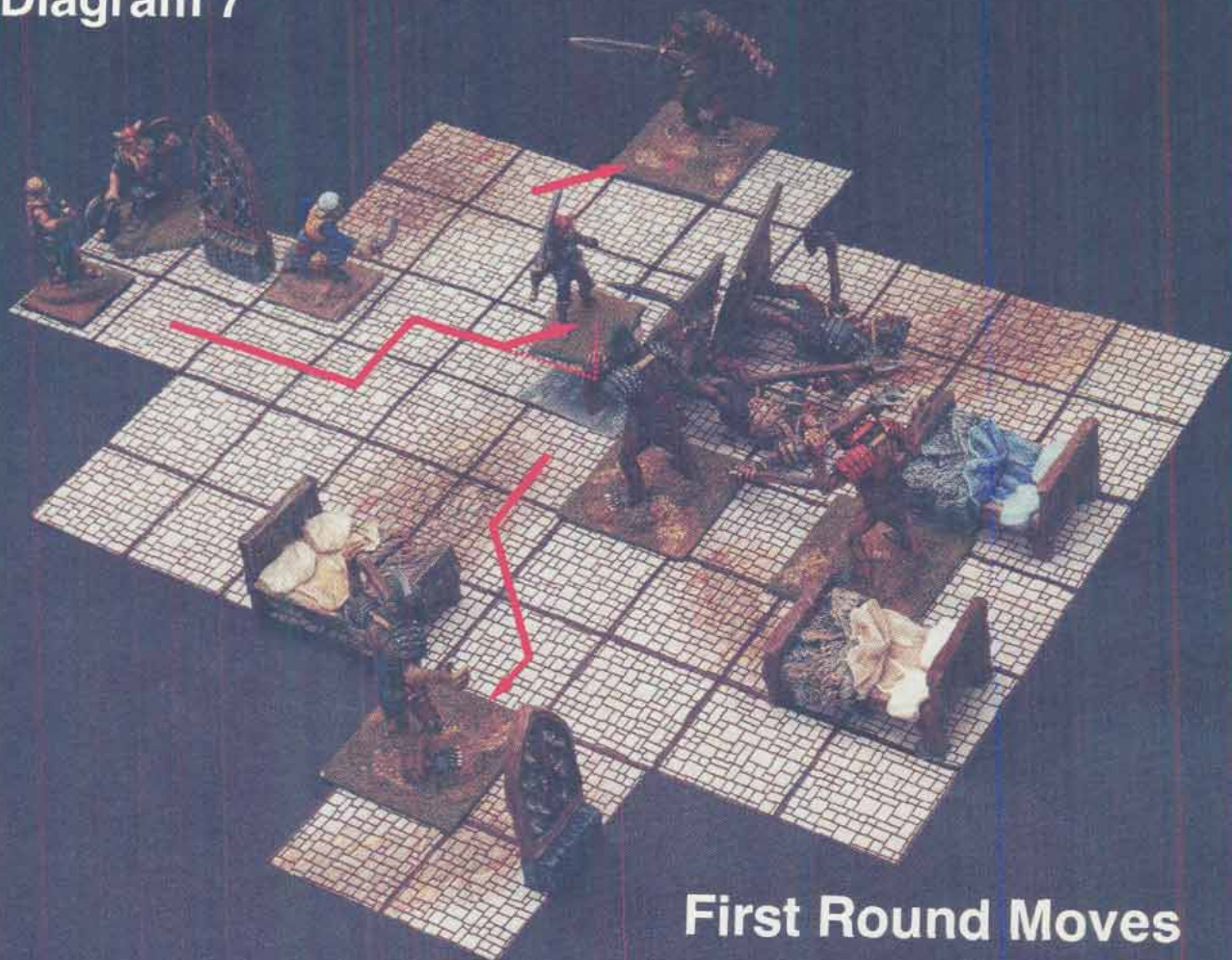

Combat System



The two bugbears moving under cover begin their moves now. The last bugbear meets Pascal. Pascal gets her attack first, but even with a +1 bonus for height advantage, she misses. Her opponent misses her as well. Damiar uses his second bow shot and fires at a bugbear using cover, missing by a mile.

At the end of the round, Pascal and Damiar have each used two points of fatigue, while Dain and Lyssa have used none. The two bugbears that took cover have each used one, while the one locked in combat has used two. There are no retreats, but the DM decides that a morale check is in order since the bugbears have seen two of their fellows knocked out of action. The bugbears pass the check, and the round is over.

Round Two

The DM decides that the two bugbears on the flanks remain under cover this round and guard. The bugbear engaging Pascal decides to take a half-move and attack, looking to open the range and take advantage of its longer reach. The last bugbear will move up to join the fight and engage Pascal. The players state their actions:

Pascal: "I'll stand my ground and attack."

Lyssa: "I'm going to move into the room to find a place to cast my next spell."

Damiar: "I'll try and shoot at the bugbear hiding around the corner. Maybe I'll get lucky."

Dain: "You guys are doing okay without me. I'll keep covering this hallway."

DM: "Roll initiative, everybody."

Diagram 8



Second Round Moves

Chapter One

The players win initiative again, rolling a 1. This accelerates their actions by a phase. In the very fast phase, Lyssa moves into the room. This time, Pascal's average sword attack becomes a fast action, as does Damiar's bow shot. Pascal misses her bugbear, but Damiar rolls another 20!

This time, Damiar's 20 is not a critical hit. The DM rules that the bugbear is under 75% cover, so it has a 7-point bonus to its Armor Class, making it effectively AC -2. Since Damiar's adjusted THACO is a 16, he only hit by 2, and he needed to hit by 5 to get another critical hit. The bugbear is wounded but still has some fight left in it.

In the average phase, Damiar fires his second arrow but misses. Finally, the bugbears can begin to move. The bugbear that is threatened by Pascal backs away,

provoking an attack of opportunity. Pascal rolls her free attack but misses. The last bugbear closes to within two spaces. Since the bugbears are Large creatures armed with weapons, they can still reach Pascal.

DM: "We're up to slow actions, and the two bugbears fighting Pascal get to make their attacks." (Rolls two attacks.) "You're lucky, they both missed. At the end of the round, nobody has to retreat. Everybody keep track of how many fatigue points you've used. Pascal, you used up two again this turn, due to your attack of opportunity."

Pascal: "Don't the bugbears have to make another morale check?"

DM: "No, nothing's changed since the last one."

Diagram 9



Third Round Moves

Combat System



At this point, Pascal has 6 fatigue points left, Damiar 2, and Lyssa 3, while Dain is still at his full amount, since he hasn't moved or fought. The bugbears attacking Pascal have 7 and 9, respectively, while the two taking cover still have 10 each.

Round Three

The DM smiles to himself—the bugbears have maneuvered the heroes right where they want them. The two bugbears fighting Pascal can guard, getting the first attack against the paladin because of their longer range. The two bugbears hiding behind the room's corners will move forward to engage Pascal's flank and Lyssa. The DM asks the players to state their actions for the round:

Pascal: "I'll move up and attack again."

Lyssa: "Cast acid arrow at the bugbear hiding in the corner there."

Damiar: "Keep firing!"

Dain: "I'll move and take a shot at a bugbear. Nothing's coming down this hallway."

The initiative roll is won by the players again, beating the bugbears with a 2. There are no very fast actions this round.

In the fast phase, Pascal moves up to threaten the bugbears facing her, but they both get attacks since they were guarding and out-ranged her. One bugbear misses, but the other hits for 5 points of damage and a roll for a knockdown. A morningstar is rated as a d10 for knockdowns, and since the bugbear is a Large creature, that is stepped up to a d12. It takes a 7 to knock down a Man-sized creature, and the Bugbear rolls a 9. Success! Pascal rolls a saving throw vs. paralyzation and fails. She is on the ground and has to use this round to stand up again.

Lyssa's spell is again fast. She throws *Melf's acid arrow* at the bugbear previously wounded by Damiar and hits it for 8 points of damage. Dain takes a half-move and steps into the doorway beside Damiar.

On the average phase, Damiar fires his first arrow of the round and misses. Pascal would have attacked this round, but decides to stand up again. The bugbears hiding around the corners move up to threaten Pascal and Lyssa.

Pascal: "Sure, now they break cover since I got knocked down."

DM: "You didn't think those two bugbears were going to stay out of the way forever, did you?"

Lyssa: "We're in trouble."

DM: "We're up to slow actions now. Dain and Damiar have shots, if they want to take them. You'll be shooting into a melee now, since there aren't any bugbears clear of the fight."

Damiar: "I'll take my chances."

Dain: "Me, too!"

Lyssa: "Hey, you could hit us!"

Dain (shrugging): "So? You can take it."

There are three bugbears who are threatening Pascal. Using the Firing into a Melee rules, the DM determines that a d8 roll should be used to resolve who becomes the target. (The three bugbears are Large and count for 2 each, and Pascal counts for 1 target. An 8 result will be rerolled.) Damiar and Dain are lucky—the target rolls end up being bugbears. Unfortunately, both characters miss with their attacks.

The two bugbears who moved in this round get to attack in their half of the slow phase. One attacks Pascal, and the other attacks Lyssa. Pascal is hit again for 5 more points of damage, but this time she isn't knocked down. Lyssa gets clobbered for 6 points of damage and begins to consider a strategic withdrawal.

At the end of the round, everyone marks off their fatigue points. Pascal loses two more, as do Dain and Damiar, but Lyssa cast a spell and loses none. The bugbears who broke cover and attacked Lyssa and Pascal lose two, but the others who were already engaged only lose one each.

Since Pascal was hit without hitting her opponents, the bugbears can force her to retreat. She is driven back one square, but the bugbears hold their ground to keep their reach advantage. The continuing damage from the *Melf's acid arrow* spell doesn't begin until next round, since Lyssa just cast the spell this round.

Round Four

In the next round, the heroes get a little lucky. Pascal downs one of her attackers with a critical hit, and Dain covers Lyssa's withdrawal and inflicts serious damage against the bugbear who had injured the mage. Another bugbear falls when the *Melf's acid arrow* finishes it off at the end of the round. With two more down, the DM rules that the survivors choose a fighting withdrawal, and the heroes let the bugbears retreat.

Chapter Two: Combat Options



Even the greenest recruits have more options in combat than to stand in one place and swing at opponents over and over again. This chapter covers tactics, options, and styles of fighting that are available to *anyone* on a battlefield. Battles aren't just a matter of who gets the lucky rolls now; smart characters can make their own luck by using sound tactics and common sense in the thick of the fight.

There are five parts to this chapter. The first is *Battle Tactics*; it covers common tactics for fighting a battle, including *shield walls*, *pike hedges*, and *mounted charges*. *Attack Options* discusses different ways to use a character's attack to achieve specific results. *Fighting Styles*, *Dueling*, and *Heroic Frays* discuss the various tactics of personal combat and how characters can employ them to their advantage.

Does This Belong in My Campaign?

Battle Tactics relies heavily on the PLAYER'S OPTION combat system, presented in Chapter One. Although the basic concepts are still sound, you won't see much game benefit to these strategies unless you are resolving battles with the combat system.

The other four parts of this chapter—*Attack Options*, *Fighting Styles*, *Dueling*, and *Brawling*—can all be incorporated into existing campaigns together or independently. They do not require the combat system to be used in your campaign. The information in this chapter replaces the related topics in the *Complete Fighter's Handbook*.

Combat Options



Battle Tactics

Over thousands of years, the tactics of battle have changed many times. Innovations of equipment and maneuver often gave armies domination of their world. Alexander's phalanxes of spearmen were nearly unstoppable. Pikes and bows brought about the end of the knight's battlefield supremacy long before firearms were effective weapons.

Some of these same tactics can be used to good effect by player characters and their opponents. Even the most foolhardy barbarian should think twice before charging a band of orcs who have formed a spearhead to receive his attack.

Shield Wall

In Chapter One, we described how figures can crowd together in close order, placing two Man-sized creatures in a single space. If the creatures stay along an even line in close order, they can form a shield wall by overlapping their shields. The shields must be medium or kite shields. Fighting with a shield wall has several benefits.

Versus Missiles

All members of the shield wall and any allies behind it are considered to be behind 50% cover (-4 AC bonus) versus missile fire. Shield walls block lines of fire indoors or underground, so in dungeon settings any *allies* behind the wall can't be targeted by hostile missile fire. The creatures actually *forming* the shield wall can still be struck, however.

Versus Melee

Since the members of the wall are in close order, shield walls allow them to concentrate their fighting power. They are also good for controlling enemy movement, especially in narrow areas such as dungeon corridors. Because the shields overlap, all members of the wall gain a -1 bonus to their Armor Class.

Creatures forming a shield wall must be of the same size or the wall

won't work. In addition, they have to move together if they want to stay linked. A shield wall can only take a half-move without breaking apart.

Creatures in a shield wall are slightly limited in their choice of armament. They can fight only with one-handed weapons since they're using a shield in the other hand. If they use a slashing or bludgeoning (Type S or B) weapon, they suffer a -2 penalty to attack rolls unless the weapon is a smaller size category than they are, because the close order interferes with the weapon's swing. Piercing (Type P) weapons aren't affected by close order.

As an example, a human barbarian (size M) forms a shield wall with his companions. He can use his short sword (Type S, size S) or spear (Type P, size M)

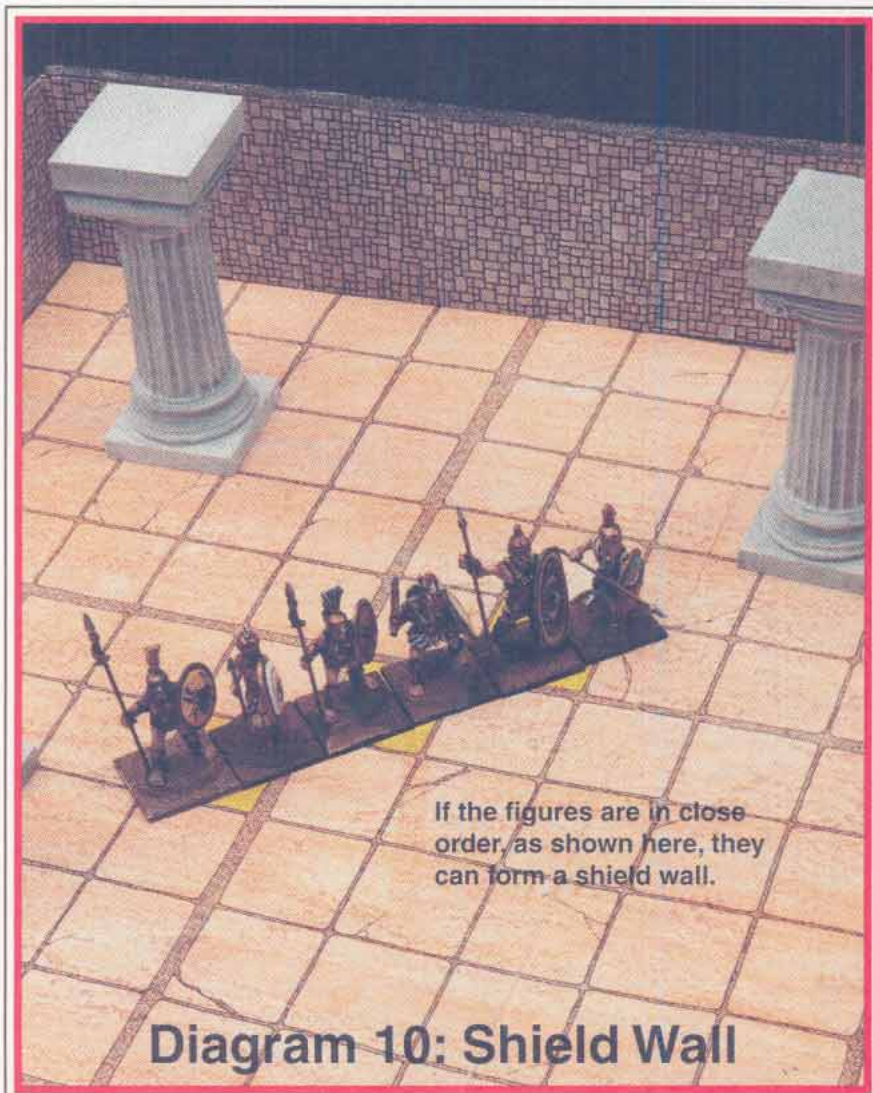

Chapter Two

without penalty, but if he fights with his battle axe (Type S, size M) he suffers a -2 penalty to his attack rolls because he's so close to his allies.

Another excellent tactic for shield walls is to place long-range polearm wielders immediately behind the shield wall. Since the polearms can reach over the shield line, enemies can be exposed to several attacks at once when they close to melee range. Using a polearm over a friend creates a -2 penalty to attack rolls, however.

Spear Hedges

Spear or pike hedges are extremely effective against creatures trying to close in for melee. Swiss pike formations could defeat the most powerful mounted charges and

could cut through many foot troops as well. Hedges don't have to be formed in close order, but they're more effective if they are. Hedges can be made doubly dangerous by adding an extra rank of spearmen or pikemen to create a defense in depth against an enemy's approach.

To form a spear hedge, characters need to stand side-by-side in an even line. A second rank can form up behind the first rank and attack over the front rank with a -2 penalty to attack rolls. If the polearm is a range-only weapon, such as a pike, then the penalty does not apply. If the troops are equipped with range 3 weapons, a third rank can be added behind the second rank.

Spear hedges are most effective when all characters choose the guard action, since any foe foolish enough to approach could be subjected to as many as 6 attacks before he could strike back. Spear hedges can only make half-moves and still remain together.

Like shield walls, spear hedges can be extremely effective in limited areas where opponents can't flank them.

Mounted Charge

One of the most spectacular battle maneuvers is a cavalry charge. There are no special considerations or formations necessary for a mounted charge; a single knight on horseback can use this tactic.

The mounted charge against foot troops gives the charging character a +2 bonus on his attack for charging and a +1 bonus for being mounted. If he's armed with a lance, he inflicts double damage if he hits. In addition, the lance's superior range may allow him to strike before the defender has a chance to attack.

The charging character can also use his mount to move through enemy figures, possibly knocking them down or trampling them. A line of armored knights can literally ride down infantrymen, although they'll provoke attacks of opportunity once they get into the press. Still, the initial shock of such a charge can decimate most infantry formations.



**Diagram 11:
Pike Hedge**

A pike hedge three ranks deep. Each figure threatens the square its pike extends into. The number of pikes could be doubled by forming the hedge in close order.

- Front Row
- - - → Second Row
- ... → Back Row

Combat Options



A great defense against the mounted charge is missile fire at the mounts. Usually, the horses are easier to hit than the riders. Any time a mount is injured, the rider must make a riding check (or roll a successful saving throw vs. paralyzation) to keep control of the animal. The riders of any animals following the injured mount must also make riding checks or be stopped by the downed animal.

Archery from Horseback

Archers on horseback are very effective against foot troops without missile weapons. (If the character on foot has a weapon to reply to the horse archer's fire, it's a different story.) Weapons suitable for use while mounted include short bows, composite short bows,

hand crossbows, light crossbows, and size S firearms.

If the archer remains still (takes a no-move action), his rate of fire and range modifiers are unaffected by his mount. If he rides a half-move, his rate of fire is reduced by one category and he suffers a -2 penalty to his attack rolls. If his mount takes a full move, his rate of fire is reduced as above, and he suffers a -4 penalty to his attack rolls. These penalties can be reduced by expertise in mounted archery; refer to Chapter Four for more information.

The best way to exploit the archer's mobility is to gallop in for a round of fire and then retreat when the foot troops try to respond. This tactical system was one of the most successful ever devised, and for a time rendered infantry nearly obsolete.



Chapter Two

Attack Options

Heroic swordsmen don't just stand still and hack at their opponents; they dash back and forth, trading parries and ripostes with skill and agility. A great way to add excitement and flavor to your battles is to allow PCs the chance to try flashy maneuvers or special tactics against their dastardly foes.

In a melee, characters can choose any number of tactics instead of a simple strike or thrust. The following attack options are available to any character proficient with the weapon he is using:

Block	Pull/trip
Called shot	Sap
Disarm	Shield-punch
Grab	Shield-rush
Overbear	Unarmed attack
Pin	Unhorse
Special weapon maneuver	

The Opposed Roll

Many of the attack options described below use a game mechanic known as an *opposed roll*. In an opposed roll, whoever comes closest to their success number without going past it wins the contest.

For example, two characters wrestling for control of one sword could be required to make opposed Strength checks to see who gets the weapon. The character with the highest d20 roll that doesn't exceed his Strength score wins the contest.

Because the goal of an opposed roll is to come as close to missing as possible without doing it, attack rolls are won by the character with the *lowest* roll that doesn't go under their required to-hit number, and ability checks are won by the character with the *highest* roll that doesn't exceed his ability score. Ties extend the contest one round, unless stated otherwise.

Block

A character can declare that she is using one of her attacks to block an opponent's strike. Blocking is a hard parry with a weapon that deflects an opponent's attack. Any weapon except rope-like things such as nets, lassoes, or slings can be used to block.

When a character tries to block an attack, she makes a normal attack roll against AC 4. Her opponent makes a normal attack roll against her Armor Class. The strike

is blocked if the character succeeds with a lower roll than her enemy succeeded with. If the attacker failed anyway, it's a miss no matter what the blocking character rolled. If the blocking character failed but her attacker succeeded, it's a hit despite the block attempt.

For example, Arweth is a 5th-level fighter with an adjusted THACO of 14 with her long sword. She is fighting a hill giant with a THACO of 9. Arweth decides to use an attack to block the hill giant's next strike. She rolls a 15 and succeeds with her roll. The hill giant rolls a 12; Arweth is AC 1, so the giant succeeds, too. His roll of 12 is lower than her 15, so Arweth's block fails.

If the character announces her block before initiative is rolled, she can block an attack even if it beats her action phase. If she decides to wait, she can only block attacks in her action phase or later.

Blocking is an excellent tactic for characters with multiple attacks to use against characters or monsters with only one attack. A rapier specialist with a main-gauche in her off hand can use her off-hand weapon or one of the rapier attacks to block while using the rest of her attacks offensively.

Called Shot

A called shot is an attack at a specific location on the target. For example, a called shot can be used to attack the head of an enemy who isn't wearing a helm, the unarmored legs of a character wearing only a breastplate, or the special weakness of a monster with an Achilles' heel.

Called shots have to be announced before the attack roll is made. When the called shot is announced, the character's action phase is delayed by one category; a bowshot that would normally be in the average phase becomes a slow action if the archer decides to make a called shot. If you're not playing with the initiative system described in Chapter One, assume called shots receive a +1 initiative penalty.

Called shots normally present the attacker with a -4 penalty on his attack roll, but the DM can modify this for the circumstances. If the target is surprised or not expecting the attack, the called shot modifier may not apply at all. On the other hand, a particularly difficult called shot (stabbing an enemy through the eyeslit of his visor, for example) may inflict a -6 or even a -8 penalty to the attack roll. Called shots are disrupted if the character attempting it suffers a knockdown.

Combat Options



Although called shots are normally most useful for special combat effects, like breaking a beaker of acid in an evil wizard's hand, they can also be useful against partially unarmored opponents. An enemy in full plate mail with no helmet has an AC 10 head; it's easier to make the called shot with a -4 penalty against that AC 10 than to swing at the enemy's normal AC of 1. If a called shot is used to strike a specific body area and results in a critical hit, ignore the location die of the critical hit roll and just roll the effect for the area struck. (See Chapter Six for more information on critical hits.)

Called shots can also be used to fire missile weapons into a melee without the risk of hitting an ally. If the called shot misses, no one else is in danger of being hit by the missile.

As an optional rule, the DM may allow called shots to be used to force an automatic retreat or knockdown effect, rather than inflict damage.

Disarm

There are two types of disarming maneuvers, offensive and defensive, and they both work essentially the same way. A character who wishes to use either type of disarm must allocate one of his attacks for the round to the feat. If the disarm is a defensive one, it is resolved *before* the attacker rolls to hit. A disarm works very much like a block, but the character attempting the disarm must roll against AC 0, while the intended victim of the disarm still rolls against an AC 4.

Anyone involved in a disarm that is using a two-handed weapon receives a 4-point bonus to the *target Armor Class* for the purposes of the opposed roll. It's impossible to disarm a weapon two sizes larger than your own, so a fighter with a dagger can't try to disarm a mage with a quarterstaff. Disarming can occur using a missile weapon, but the missile's size is the factor used to determine whether or not the attempt can succeed, not the weapon firing the missile.

For example, Dain the dwarf warrior is fighting a human sellsword named Torath. Dain announces before initiative that he will use one of his attacks for a defensive disarm on Torath's attack that round. Before Torath attacks, he makes an opposed roll against AC 4 while Dain rolls against AC 0. Torath's THAC0 is 17 and Dain's is 13. Torath rolls a 15, good enough to hit AC 4, while Dain rolls a 12, not quite enough to hit AC 0. Torath avoids Dain's disarm attempt and proceeds normally with his attack roll.

If Dain had been wielding a two-handed axe, his roll would also have been against AC 4 (the 4-point bonus to AC 0), and his 12 would have been good enough to hit. Since his 12 was lower than Torath's 15, Dain would have won the opposed roll and disarmed Torath.

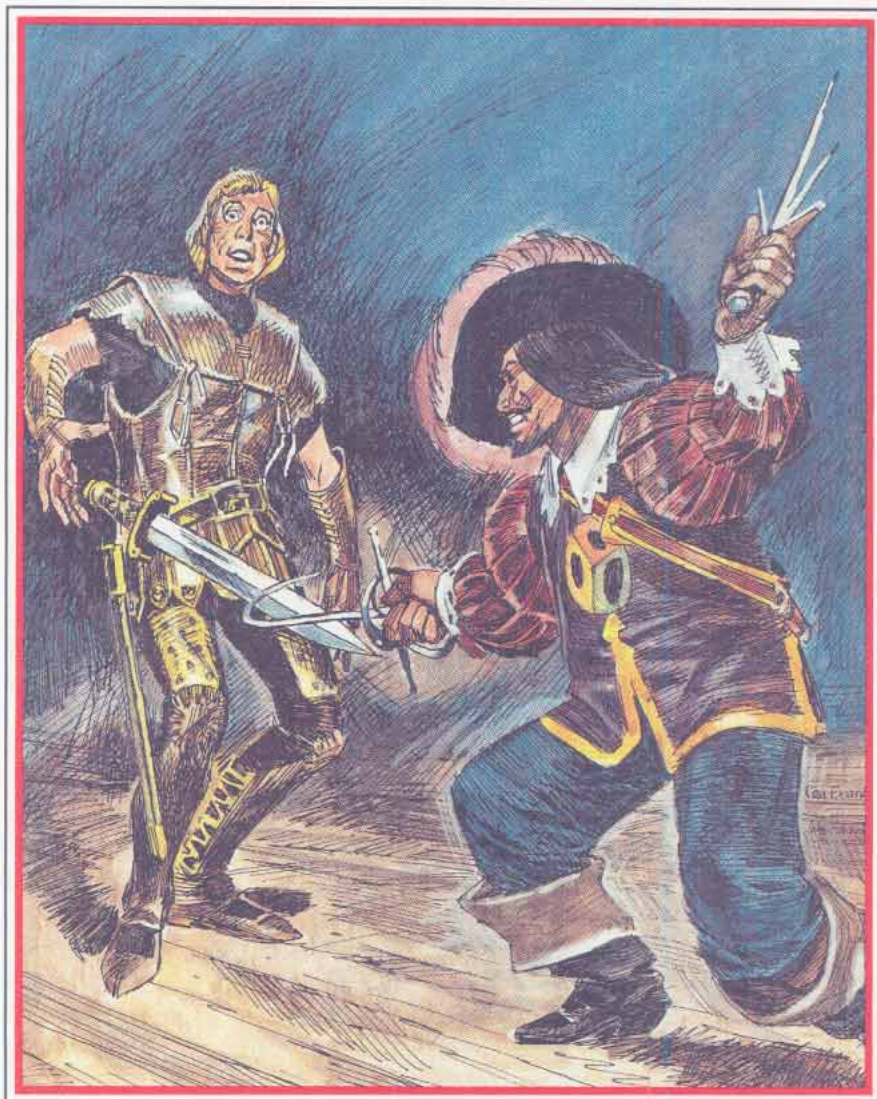

Chapter Two

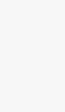

Defensive disarms work just like blocks for initiative; if announced before the roll, they can be attempted against attacks that beat the character's action phase. Otherwise, they can only be used on the character's action phase or later in the round. Offensive disarms work like called shots; when announced, they delay the character's action phase by one step. The intent to disarm has to be announced before any rolls are made.

When a weapon is disarmed, it falls 1–10 feet away (1d3–1 squares) in a random direction. Recovering a disarmed weapon requires a half-move. A disarmed character can be immediately covered if the attacker has an attack remaining in the round.

Disarms work best against low-level opponents who don't have good THACOs, since it's difficult for them to make their opposed rolls.

Grab

Characters can grab weapons or important items away from their opponents. If the character wants to grab his opponent directly, he should consider it a wrestling attack and resolve it as unarmed combat; see Chapter Five. A character has to have a hand free to grab; if both hands are full, he's got to drop something in order to attempt the grab. (Two-handed weapons can be held in just one hand, but the character can't attack this way.) The attacker must announce the grab attempt before he makes his attack roll.

Trying to grab an enemy's possessions while he threatens you is a bad idea; the defender receives an immediate attack of opportunity against the grabber.

Generally, the grab attempt works the same way a disarm attempt does. The character attempting to grab an item must make an opposed roll against AC 0 while the intended victim rolls against AC 4. The DM may assign certain penalties to the character attempting the grab, depending on circumstances; grabbing a tiny ring on someone's finger might incur a –8 penalty to the target Armor Class for the grabbing character. If the opposed roll results in a tie, the item may be dropped or broken at the DM's discretion.

For example, Euserio the Bold is behind the evil wizard Warjo and decides to grab Warjo's wand of lightning. There's no attack of opportunity, since the hero wasn't threatened by Warjo. The DM rules that there is no penalty to Euserio's attempt, since Warjo has the wand in his hand and isn't paying Euserio any atten-

tion. Euserio and Warjo make the opposed roll, Euserio against AC 0, Warjo against AC 4. Euserio's THACO is a 16, while poor Warjo's is still a 20. Euserio scores a hit with a roll of 18, while Warjo rolls a 12 and misses, so Euserio gets his hands on the wand.

Once the grabbing character succeeds in grasping the item, the opponents must wrestle for control of it using opposed Strength checks. If a character only grabs (or was originally holding) the item with one hand, then his Strength is reduced by 3 points.

Continuing our example, Euserio and Warjo now struggle for control of the wand, making opposing Strength checks. Euserio's 17 Strength is reduced to an effective 14 because he only got one hand on the wand, and Warjo's 13 becomes a 10. Euserio makes his Strength check with a 6, but Warjo rolls a 9 and wins, jerking the wand away! Wonder what he'll do with it next round?

Overbear

The best attack against a warrior of heroic prowess is often a simple rush. Overbearing is a common tactic when several creatures are confronting a lone enemy who can cut them to pieces one at a time. Overbearing attackers throw themselves at their opponent, using whatever holds they can find to get him on the ground and restrain him.

Overbearing is hazardous; the defender gets an attack of opportunity against any attacker he threatens (up to the limits imposed in Chapter One). It can take a concerted rush of a dozen or more to get through a high-level fighter's guard. Overbearing is treated as an unarmed attack, and is resolved on the base initiative of the slowest attacker in the pile.

The overbearing force resolves the attack by making a single attack roll at the THACO of their best member. The attackers get a +1 bonus to hit for each additional attacker. The attack is made against the defender's natural Armor Class (AC 10 for most PCs), only counting magical and Dexterity adjustments—a man in plate mail is just as vulnerable to being pulled down as a man in leather armor.

If the attackers hit, they must make an opposed Strength check against the defender to see if they drag him down or not. Use the Strength of the largest attacker, and apply the following modifiers:

Combat Options

- 4-point bonus or penalty per size difference of the largest attacker versus the defender;
- +1 per additional attacker;
- -4 if defender has more than two legs.

Monsters can be assumed to have a Strength of $3\frac{1}{2}$ points per size category (3 for Tiny, 7 for Small, 10 for Man-sized, 14 for Large, etc.) plus their Hit Dice. If the defender wins the Strength check, he keeps his feet and shrugs off the attack. If the attackers win, the defender is knocked down. The defender can be pinned and restrained if he is successfully overborne again in the next round.

For example, six kobolds are fighting Alvoth, a human knight. The monsters decide to use their numbers against Alvoth and overbear him. Alvoth kills one of the kobolds in an attack of opportunity as the monsters close, but the other five try to overbear anyway. Alvoth is normally AC 0, but his chain mail and shield don't help him here, only his Dexterity of 18. The kobolds attack against an AC of 6, with a +1 bonus to hit since they outnumber him.

The kobolds score a hit, so Alvoth engages in a Strength contest to keep his feet. Kobolds should have a Strength score of 7 based on the formula above ($3\frac{1}{2}\times 2$ for Small). However, their effective Strength is increased to an 11 due to their numbers (4 extra kobolds). Alvoth has a Strength of 17 and rolls a 9, making his Strength check. The kobolds roll an 11, just making their check with a higher roll and winning the contest. Alvoth goes down beneath the brutes' rush.

As an option, a saving throw vs. paralysis can be substituted for the opposed Strength checks. This works a little faster, but it's not as accurate as the system described above.

Pull/Trip

A good tactic against moving enemies or characters who aren't paying attention is a trip or tangling maneuver. To pull or trip an opponent, the character must be armed with a weapon that has the ability to snare someone's legs. The following weapons all qualify: bill, bola, bow, light or heavy crossbow, horseman's flail, harpoon, javelin, khopesh, lasso, mancatcher, net, footman's or horseman's pick, any polearm, quarterstaff, scourge, spear, staff sling, and whip. These weapons feature long, staff-like pieces, chains or ropes, or heads that can catch and pull an enemy's legs out from under him.

To pull or trip an enemy, the character makes a normal attack roll. If he hits, he makes an opposed roll of his Strength against the defender's Dexterity or Strength,



Chapter Two



whichever is better. If the attacker wins, the defender is knocked down. If the defender wins or if both fail, the attack fails. If the roll is a tie, they both fall down.

For purposes of this maneuver, a monster's normal movement rate can be considered its Dexterity score. Its Strength is equal to $3\frac{1}{2}$ points per size plus its Hit Dice. There are several modifiers that apply to the attacker's Strength, however:

- 4-point bonus or penalty per size difference of the attacker versus the defender;
- -2 to attacker's Strength if the target has four legs or more;
- +3 if the defender was unaware of the pull or trip attack;
- -6 if the defender was stationary.

For example, Alvoth is waiting in ambush for the king's messenger to come galloping down a wooded lane. He decides to use his halberd to trip the horse when it comes by. If he hits, he'll use his Strength against the horse's move of 18. Alvoth's Strength is modified by -4 for the size difference and -2 for the horse's extra legs, but +3 because he is hiding, so his 17 Strength is an effective 14 for purposes of tripping the horse.

Optionally, the opposed roll can be replaced by a simple saving throw vs. paralyzation. It's not as accurate, but it may be more convenient for the DM and players to remember.

Sap

Sapping is an attempt to knock out an opponent by striking with the flat of the blade or slugging him from behind with a sturdy sword-hilt. It doesn't work very well against characters or monsters that are expecting it; any character attempting to sap a creature that threatens her provokes an attack of opportunity for the defender. Hand-held weapons and thrown weapons may be used in sap attempts.

A sap is a type of called shot; it has a one-phase initiative penalty, and the attacker has a -4 penalty to hit. The penalty increases to -8 if the defender is wearing some kind of helmet. Only Small or Medium creatures can be sapped; Large monsters can't be knocked out like this.

If the attacker scores a hit, she may knock out her opponent. There is a 5% chance per point of damage of knocking out the victim, up to a maximum of 40%. Thus, if the sapper inflicts 5 points of damage, she has a 25%

chance of knocking out her opponent. Sapping damage is like unarmed combat damage; 25% is real and the rest is temporary. Naturally, if her damage roll exceeds the victim's hit points, he's knocked out anyway.

The knockout chance increases to 10% per point of damage (max 80%) if the victim is surprised, asleep, restrained, or magically held in some way. Sapped characters remain unconscious for 3d10 full rounds.

Shield-Punch

Any character equipped with a shield can choose to forego its protection and gain an extra attack known as a shield-punch. The shield-punch is treated as a normal, secondary weapon attack; the primary weapon suffers a -2 penalty to attack rolls that round and the shield-punch attack is rolled with a -4 penalty. A character may use his reaction adjustment due to a high Dexterity score to offset these penalties. Alternatively, the character can *substitute* his normal attack for a shield punch, with no penalties.

The exact characteristics (i.e., damage and speed) of each type of shield are noted on page 51. If the character is trying a shield-punch, he must announce his intention while declaring his combat action and forfeits the defensive benefit of the shield for the round. The character moves into the square of his opponent on his base initiative, then executes the shield punch and backs out into his own square again on the following initiative phase.

Shield-Rush

The shield-rush is an attempt to knock someone down by running into them with your shield. The character must have 10 feet (2 spaces) of running room to make an effective shield-rush. Making a shield-rush is treated as a charge attack for purposes of guarding characters with set spears.

When the character makes a shield-rush, he makes a normal attack against his enemy's AC. Some shields may provide modifiers or bonuses to the rush; refer to Chapter Seven. After a shield has been used for a rush, it provides no AC bonus for the rest of the round for its bearer. Making a shield-rush also costs the character a normal attack, but it isn't considered an off-hand weapon like a shield-punch.

If the shield-bearer hits with his attack, he makes an opposed Strength roll against his opponent to see if he knocks him down. The loser of the opposed roll falls

Combat Options



down; if both characters fail their Strength rolls, they both fall down. The following modifiers apply to the attacker's Strength score:

- 4-point bonus or penalty for each size difference of the attacker versus the defender;
- +3 if the defender was unaware of the shield-rush;
- -2 if the defender has four legs or more.

As noted before, monsters can be assumed to have a Strength of $3\frac{1}{2}$ per size category plus their Hit Dice. Instead of an opposed roll, the DM can substitute a saving throw vs. paralyzation for the defender to save time.

If the shield-rusher misses with his attack roll, he must roll a successful Dexterity check to stay on his feet as he rushes past his target. If he fails, he falls down.

Special Weapon Maneuver

Several weapons have special properties that can be used to great effect by a skilled wielder. The bolas, chain, harpoon, lasso, mancatcher, and net all have special effects that can be used against opponents. The exact nature of each weapon's special maneuver is discussed in Chapter Seven.

Generally, using a special weapon maneuver requires a called shot that delays the wielder's action phase by one step and gives him a -4 penalty on his attack roll.

Trap

It's possible to use your weapon or shield to pin your enemy's weapon against his body or to trap the weapon on your own sword-hilt or weapon haft. This maneuver is known as a trap. Traps are much like blocks; the character can get a chance to trap an attack that comes before his action phase by declaring the trap before initiative is rolled, or he can trap any attack that comes in his action phase or later without declaring his action beforehand.

Like with a disarm, the trap is resolved *before* the normal attack roll is made. A character attempts to trap an enemy's attack by rolling an opposed attack roll versus AC 0 while his opponent rolls against AC 4. If the trapping character wins the opposed roll, the weapon is successfully pinned. Otherwise, the pin fails and the normal attack roll is made.

Once an enemy's weapon is trapped, he loses any additional attacks he could have made with that

weapon in the current round. At the end of the round, the trapping character and his victim make opposed Strength rolls to see if the victim can free his weapon. In each subsequent round, one Strength check is made on the fastest character's base initiative, and a second one at the end of the round.

A character with a trapped weapon can always attack with a secondary weapon or simply abandon the weapon that's been caught. The character who performs the trap cannot use the weapon or shield he's pinning the opponent's weapon with.

Trapping is an excellent tactic to use against an opponent with fewer attacks. It is also a good tactic for a two-weapon fighter to use against a single-weapon fighter; by sacrificing one weapon's attacks, he completely stops his opponent's offense. Another sneaky trick is to have an ally trap a tough opponent's weapon to free up unanswered flank or rear attacks for a second character. Trapping is tougher than a simple block, but worth the effort.

Trap and Break

Some weapons, such as the sai or the swordbreaker, are suited for breaking a trapped enemy weapon. When a weapon of this type is used to trap an enemy weapon, the trapping character can declare an attempt to break the weapon. The trapped character must roll a successful item saving throw vs. crushing blow for his weapon or it breaks; for metal weapons, this is a 7 or better on 1d20. The weapon's magical bonus applies.

If the break attempt fails, the trapped blade is automatically freed. Otherwise, the weapon is broken. Only swords, knives, or weapons with sword-like components (such as a halberd's spike or a glaive) can be broken.

Unarmed Attack

Throwing a punch or trying to get a wrestling hold on the enemy is always a legitimate attack. As noted in Chapter One, trying to engage an armed opponent in unarmed combat is risky; if the armed character threatens the attacker, he gets an immediate attack of opportunity.

There are several types of unarmed attacks that can be employed by a character, including punching, wrestling, martial arts, and overbearing. The various types of unarmed combat are described in great detail in Chapter Five. Note that a character has to have a hand free to punch or wrestle someone.



Combat Options



Unhorse

A mounted enemy can be knocked off his steed by a number of methods. Whenever a character is in danger of falling off his horse, he must roll a successful riding proficiency check (or a saving throw vs. paralyzation if he doesn't have the riding proficiency) to remain in the saddle. If he fails, he's considered to be knocked down and is lying prone on the ground.

Some ways to unhorse a mounted character include:

- **Knockdown:** Striking a mounted character or the mount hard enough to create a knockdown chance;
- **Damage:** Striking a mounted character for 10 or more hit points of damage;
- **Pull/Trip:** Hitting a mounted character or the mount itself with a pull/trip attack;
- **Overbearing:** Successfully grappling a mounted character with an overbearing attack (he may also be pulled down by losing the opposed Strength check to fight off the overbearing attempt);
- **Damage to the Mount:** Wounding a mount during the battle (killing the steed always unhorses a character, no questions asked).

Fighting Styles There are almost as many different ways of fighting as there are fights. Every character and monster has his or her favorite weapon and preferred means of attack. Fighting styles are general ways in which a character can equip himself for a fight and execute his attacks during the battle.

If a character doesn't know a fighting style, he can learn it at the cost of a proficiency slot. Warriors can actually specialize in fighting styles to gain bonus attacks or defenses; this is covered in Chapter Four.

Single Weapon

In single-weapon style, the character wields a one-handed weapon and leaves his off-hand empty. There are some disadvantages to this style, in that the character is shorting himself the protection of a shield or the extra offense of a secondary weapon. However, single-weapon style *does* leave the character with a hand free for using magical items, grabbing, or punching an opponent.

If the single-weapon character makes an off-hand attack, such as a punch or grab, he's considered to be

fighting with two weapons. His primary weapon suffers a -2 penalty to attack rolls and his secondary attacks suffer a -4 penalty to hit. These penalties are offset by the character's reaction adjustment for his Dexterity score.

All player characters, regardless of class, know the single-weapon fighting style.

Two-handed Weapon

The largest and most damaging weapons available to PCs are usually two-handed weapons. Obviously, a character with a two-handed weapon is not going to be able to use a shield or a secondary weapon, but he does have a lot of offensive capability.

Many two-handed weapons are polearms and extended-range weapons that provide the wielder with special tactical benefits in addition to their raw damage potential. Note that a character doesn't have to use both hands just to hold a two-handed weapon; he can hang on to it with one hand to free up the other for another activity, but he can't attack until he gets both hands on the weapon again.

Size and Two-handed Weapons

Generally, a character can use a weapon equal to his own size in one hand, and a weapon one size larger in two hands. For example, a halfling (size S) can use a short sword or hand axe in one hand, since they're size S weapons, but if he used a broadsword (size M) he'd have to use it two-handed, and there's no way he could use a longbow or halberd.

One- or Two-handed Weapons

Several weapons can be used as one-handed or two-handed weapons. These include the bastard sword, harpoon, javelin, spear, long spear, and trident. These weapons' characteristics change when used two-handed; refer to Chapter Seven.

One-handed Weapons used Two-handed

Several other weapons are normally one-handed weapons that can be used two-handed if the wielder so desires. There's no particular reason to do this, unless the character's too small to wield the weapon any other way. These weapons include the battleaxe, club, footman's flail, horseman's flail, long sword, footman's mace, horseman's mace, morning star, footman's pick, horseman's pick, and warhammer.

Warriors, priests, and mages normally know the two-handed weapon fighting style.

Chapter Two



Weapon and Shield

One of the most common fighting styles in the AD&D game, this style provides the character with the defensive benefits of a shield and still allows a decent offense. In addition to the AC benefit of the shield, this style also gives the character the attack options of shield-punch and shield-rush.

There are two disadvantages to this style: first, the character is limited to using a single one-handed weapon, since his other hand has the shield; secondly, if he wants to quickly empty a hand, he has to drop his weapon. Most shields are strapped to the character's arm and take a full round to remove.

Warriors and priests normally know the weapon and shield fighting style.

Two Weapon

Not to be confused with the two-handed weapon style, two weapon style uses a weapon in each of the character's hands. The advantage of this is clear: the character either has more attack power or can use the secondary weapon defensively to block incoming blows. Another benefit lies in the fact that even if the character loses a weapon, he's still armed.

The character can use any one-handed weapon in his primary hand, but his secondary weapon must be a size smaller than his primary weapon. Knives and daggers can always be used, regardless of the primary weapon's size. The character suffers a -2 penalty to attacks with the primary weapon, and a -4 to attacks with the secondary weapon. This penalty is offset by the character's reaction adjustment for high Dexterity.

Important Note: While the character receives his normal number of attacks for class, level, and specialization with his primary weapon, he only receives *one* additional attack with his secondary weapon.

Warriors and rogues know two weapon fighting style.

Unarmed

Some characters prefer to fight with their fists and feet instead of weapons and shields. Generally, a character can make one wrestling or overbearing attack or two punching attacks per round. If a character is using a weapon in one hand, he can use his second hand for an additional attack, just like fighting in two-weapon style. However, the bare-handed attack creates an attack of opportunity for the defender if he threatens the attacker.

All characters can punch or wrestle; it doesn't even require a weapon proficiency. It's possible to specialize in unarmed combat and become better at hand-to-hand fighting—refer to Chapter Five for more information.

Missile or Thrown Weapon

Fighting with missiles or thrown weapons is an excellent option, as long as you can keep your target at a range where you can hit him without being hit. Once an enemy threatens an archer or slinger, it's a good idea to either withdraw or change weapons.

Regardless of a character's size, using a bow, crossbow, sling, blowgun, or firearm at its normal rate of fire requires both hands. Crossbows and firearms can be loaded with both hands and then aimed and fired in one hand, if the attacker's size is equal to the weapon's size or larger. However, heavy crossbows, arquebuses, calivers, and muskets suffer a -2 penalty to the attack roll if aimed one-handed.

Multiple Loaded Weapons

If a character is able to cock and load several crossbows or ready several firearms for firing, he can get several shots off very quickly. As long as the character has loaded weapons close at hand, he can *triple* his normal rate of fire. When he runs out of loaded weapons, he'll have to resume firing at the normal rate.

Thrown Weapons

Most thrown weapons only require one hand to use; there's no reason why a character couldn't carry a shield or a second weapon in his off-hand. A character can't throw weapons and make a melee attack in the same round—he has to choose one or the other.

Size M or larger thrown weapons can be used in conjunction with a charge attack. The character performs his charge as normal, but he pulls up short of his target by 10 to 20 feet and uses his momentum to add to the javelin or axe throw. This attack confers the movement and $+2$ attack bonus of a charge, but the attacker suffers the charge penalties, too.

Weapon-Specific Styles

Many specialized fighting styles and weapon combinations have developed over the history of personal combat. Some examples of these special cases include the net and trident, matched sai, nunchaku or fighting sticks, and the rapier and main-gauche.

Combat Options



The exact benefits of each weapon-specific style are described in Chapter Four. Generally, these efficient weapon pairings tend to offset the penalties of fighting in two-weapon style or provide extra defense when used together.

Dueling When two skilled fighters meet in personal combat, their contest runs far deeper than simple attacks, blocks, or traps. If a boxer dodges to his left when his opponent throws a right jab, or ducks when his opponent throws a body punch, he's at a distinct disadvantage. The same thing can happen in a melee between two armed combatants.

The subtle patterns of attack and defense create temporary advantages or disadvantages for characters involved in a duel. Leaping over a low axe sweep is a great way to avoid getting hit . . . but what if you guessed wrong and your opponent aimed high? This section presents an optional set of rules for resolving duels between skilled warriors.

What's A Duel?

For our purposes, a duel is any fight that takes place between a PC and one humanoid enemy armed with a weapon of some kind. It doesn't begin, though, until the two combatants have actually engaged in melee. Don't begin using these rules, including the special initiative system below, until this happens.

Generally, it's not worth the extra time and effort to use

the dueling rules unless the enemy is close to the PC's own skill level; if the hero can clean the villain's clock within a round or two, don't bother to use these rules.

Duels are best saved for confrontations with major NPC villains. If more than one character or creature is engaged on either side, the fight doesn't count as a duel anymore; the subtleties of attack and defense are quickly lost when several combatants become involved. The DM has the authority to declare that a duel has turned into a normal melee whenever he sees fit.

Initiative

In a duel, initiative works differently than it does in a normal melee. Roll initiative normally at the beginning of the fight, but disregard any critical events—this is a contest of skill, not luck. The character that wins initiative is called the attacker, and his opponent becomes the defender.

After the first round, duels don't have initiative rolls. Instead, the attacker retains the initiative until one of the following events occurs:

- He chooses a combat action that does not require an attack roll in a round;
- The defender disarms or traps the attacker's primary weapon;
- The attacker is knocked down or forced to retreat by the defender;
- The defender overbears, trips, or otherwise grapples the attacker.

When the initiative shifts, the effects are immediate—if an attacker loses the initiative in the fast phase, his opponent is considered to have the initiative in the average, slow, and very slow phases of that same round, as well as the following round (or at least until the new attacker loses the initiative.)

The Dueling Plot

Before a duel begins, both of the participants should have a copy of the dueling plot (provided on the opposite page for you to photocopy). There are two basic parts to the diagram: the positioning symbols and the attack and defense lists.

At the beginning of each round of a duel, the attacker and defender both secretly choose their strategies of attack,

Shield Punch

Shield Type	Size	Speed	Reach	Damage	Knockdown
Small	S	Fa (2)	1	1d3	d6
Medium	M	Av (6)	1	1d4	d8
Large	L	Sl (8)	1	1d6	d10

Shield Rush

Shield Type	Size	Speed	Reach	Damage	Knockdown**
Small	S	Base*	1	1d3	0
Medium	M	Base*	1	1d4	+1
Large	L	Base*	1	1d6	+3

*A Shield Rush is performed in the attacker's base initiative phase.

**The knockdown bonus is used during the opposed Strength check that takes place if the attack hits (see Chapter Two, page 46). If the character's Strength check succeeds, add the listed number to the roll before the two rolls are compared.

PLAYER'S OPTION™

Dueling Plot

High

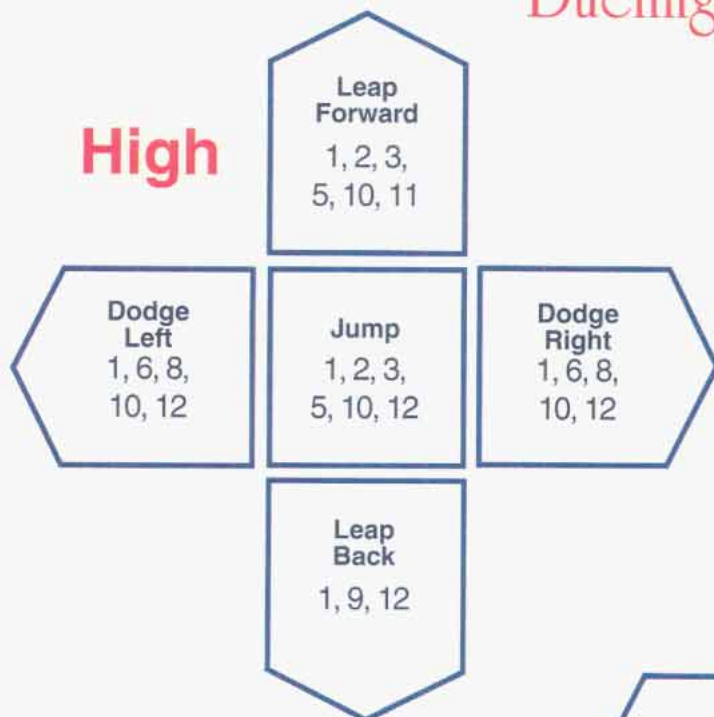

Defenses d6

1. None
2. Block
3. Defensive Trap
4. Defensive Disarm
5. Shield Disarm
6. Parry

Press
1, 2, 3, 5, 11



Middle

Backpedal
1, 5, 9

Tumble Forward
1, 4, 11

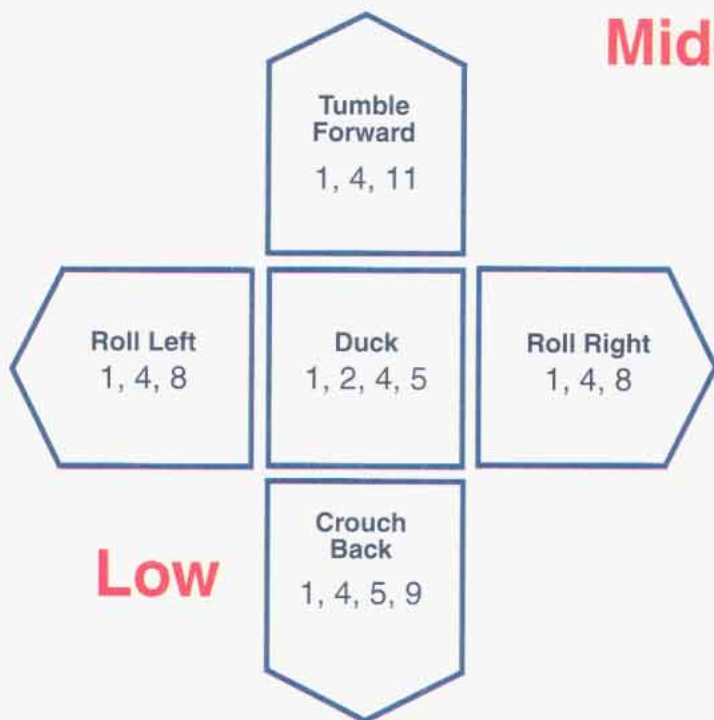

Low

Attacks d12

1. Normal Attack
2. Shield Punch
3. Sap
4. Pull/Trip
5. Trap
6. Offensive Disarm
7. Feint: +1 vs. riposte, disarms
8. Outside Attack: +1 vs. shields, slides
9. Riposte: +1 vs. smash, wild swing, outside attack
10. Smash: +1 vs. block, parry
11. Close Attack: +1 vs. longer weapons
12. Wild Swing: +1 vs. no defense

Combat Options



defense, and position. The attack and defense forms are represented by numbers on a concealed die; the attack form uses a d12 and the defense a d6. The lists on the dueling plot indicate which forms are available and what effects and adjustments apply. The position symbols are used to indicate how the duelist moves *defensively* in the round.

To set up a maneuver, each player first takes the defensive die (the d6) and chooses a defense form, then positions it in the space desired. Next, an attack form is selected on the attack die (the d12). Note that not all attack forms are allowed with every defensive maneuver. The numbers in the position spaces indicate which attack choices are valid with that kind of defensive movement. After all, it's pretty hard to perform a close attack on someone when you're leaping back. Finally, the attack die is positioned where the duelist anticipates his opponent will go.

Attacking in the Right Spot

Anticipating where your opponent will go is an important part of the duel. If you apply your attack to the exact point that your opponent is moving defensively, your duelist gains a +2 bonus to the attack roll. For every direction (stationary, forward or backward, left or right) and every level (low, middle, high) that you are off, a 2-point penalty is applied.

For example, Eusebio is involved in a duel with his archnemesis, Darius the Dastardly. Eusebio's player secretly chooses to step to the left and perform a defensive block maneuver. At the same time, Eusebio will perform a normal attack, anticipating that Darius will leap back.

Darius, however, decides to tumble forward, making a normal defense and a normal attack. Since Eusebio guessed incorrectly two direction places (from back to stationary, stationary to forward) and two levels (high to medium, medium to low), he will suffer a -6 penalty to his attack roll (he starts with a +2 bonus, but loses four 2-point penalties for the four displacements).

Reading an Opponent's Move

After both characters have set their attack pattern, but before they are revealed, one duelist can attempt to "read" the other's moves. The duelists make an opposed Intelligence check. Whichever duelist wins has

picked up on some telegraphed move by his opponent. If neither duelist makes a successful check, no pattern reading occurs. Alternatively, the duelist who holds initiative automatically gets to make a "read."

In either case, the winner gets to ask about *one* aspect of his opponent's pattern. He may choose to ask what kind of attack is coming, what kind of defense is being used, or the position of his opponent's defense. Once this is done, the duelist who has made the read may adjust *one* aspect of his own pattern accordingly. If he chooses to change the position of his attack, then he may only adjust it by one space, either directionally or by one level.

Continuing our example, Eusebio wins an opposed Intelligence check and questions Darius's player on the direction Darius intends to move defensively. Upon seeing how badly he miscalculated, Eusebio decides to adjust his attack from a leap back to a backpedal, reducing his penalty from a -6 to a -4. Alternatively, he could have chosen to change his attack style to a wild swing, gaining a +1 bonus to hit, but his final penalty would have been at -5.

Moving the Figures

After the patterns are established and read, combat is conducted as per the combat system in Chapter One. If a figure must close to make an attack, the figures are moved accordingly. At the end of the round, the players must move their figures on the board one space in the direction they chose as their defensive positioning. In other words, if a duelist tumbled forward, that figure moves forward one space.

If for some reason the two figures end up in the same square, an opposed Strength check is made to see who

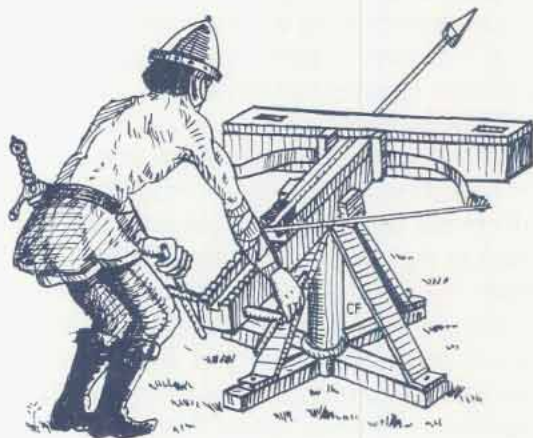

Chapter Two



gains the square and who is pushed back a square. The combatant who wins the square always pushes his foe in the opposite direction from where the winner came in.

Choice of Defense

There are six different defenses that a dueling character can choose from when building his attack pattern for the round. The defenses are:

- 1 **None:** The character chooses to use a standard defense, not utilizing any unusual maneuvers.
- 2 **Weapon Block:** The character allocates an attack for the block maneuver, using a weapon to catch one of his opponent's attacks.
- 3 **Defensive Trap:** The character allocates an attack to perform the trap maneuver. The trap itself can be performed with a primary or secondary weapon or even a shield.
- 4 **Defensive Disarm:** The character allocates an attack to perform a defensive disarm.
- 5 **Shield Block:** The character allocates an attack for the block maneuver, using a shield to catch one of his opponent's attacks.
- 6 **Parry:** The character chooses the combat action parry, making no attacks this round. Parrying provides the character with a bonus to his AC equal to $\frac{1}{2}$ his level, or $\frac{1}{2}$ his level plus one if he is a warrior.

Choice of Attack

Duelists can also choose one of twelve types of attack:

- 1 **Normal Attack:** The duelist uses no unusual maneuvers, simply attempting to land a normal blow with her weapon.
- 2 **Shield Punch:** The duelist allocates one of her attacks to performing a shield punch.
- 3 **Sap:** The duelist attempts to use her attack to knock her opponent unconscious.
- 4 **Pull/trip:** The duelist tries to use her weapon to hook or snare her opponent's legs and pull him off his feet. She must allocate an attack for this option.
- 6 **Offensive Disarm:** The character allocates an attack to the offensive disarm option.
- 7 **Feint:** The character tries to draw out her opponent by faking an attack in one location and then attacking somewhere else. The feint is particularly effective against ripostes and disarms, and therefore provides a +1 bonus against those types of attacks.

- 8 **Outside Attack:** The character tries to attack around her opponent's guard, striking to the side of a shield or at a sliding opponent. This maneuver offers a +1 bonus against a shield block or a slide position. Flails are also very good for this and get a +1 attack bonus above and beyond any other bonuses for this maneuver.
- 9 **Riposte:** The character waits for her opponent to launch an attack and expose a weakness, and then she strikes in return. A character who ripostes must wait until after her opponent has attacked before she can make her own attack in that round. However, the riposte maneuver offers a +1 bonus to hit against smashes, wild swings, and outside attacks.
- 10 **Smash:** It's not elegant, but beating down a weaker character's defenses is a legitimate tactic in a fight. This type of maneuver offers a +1 bonus to hit versus blocks and parrys.
- 11 **Close Attack:** The duelist tries to get inside her opponent's guard and attack at close range. This maneuver provides a +1 bonus against opponents with larger weapons, but it cannot be used if the character's own weapon size is larger than her opponent's.
- 12 **Wild Swing:** Foregoing all thought of defense, the character tries to make as many attacks as possible by raining a fusillade of blows on her opponent. Wild swings gain a +1 bonus to attacks against normal defenses.

Ending a Duel

Duels don't have to be fought to the death; in fact, there are lots of villains and monsters that would rather not get killed if it's possible to surrender and live. Some other common conditions for duels include fighting to first blood, fighting until someone is wounded (usually 25% or 50% loss of hit points), fighting until disarmed or knocked down, and any number of other alternatives. In social confrontations, the area's culture may have dueling traditions that define the normal forms of combat and victory.

For example, in Norse cultures, duels might be resolved in a *holmgang*, or island-going; the two parties involved meet on a small island, with no seconds or bystanders, and only one is permitted to return. Other duels may be considered over when the blood of one of the fighters stains a white sheet on which they fight, or when an impartial judge rules that one character or the other has been defeated.

Chapter Three: The Battlefield



For thousands of years, climate and terrain have played critical roles in the development of military tactics and the evolution of the battle. In flat, open lands, cavalry became the dominant force on the battlefield because the terrain favored mobility. But even the best horsemen lose most of their mobility in heavy forest, swamp, or rugged mountains. The commander who learns to use the terrain to his advantage becomes a formidable enemy.

In many AD&D games, the battlefield itself is often ignored or portrayed in a colorless, abstract manner. This chapter explores the various types of battlefields and their characteristics, with two goals in mind: creating more scenic and visual sites for your PCs' heroic encounters, and providing players and Dungeon Masters with another level of battlefield detail to reward quick thinking and sound tactics.

The first section of this chapter, *Battlefields*, discusses sites common to adventurers in role-playing situations and defines battlefield characteristics and terrain. Settings ranging from ice plains to tropical jungles are all included. The second part of this chapter, the *Battlefield Generation System*, provides the DM with an easy way to quickly create a complete battlefield for any encounter. The last part of this chapter is *Combat Under Unusual Conditions* and deals with a variety of strange situations.

Does This Belong in My Campaign?

Even if you are not using the PLAYER'S OPTION combat system presented in Chapter One, you'll still find that most of the material in this chapter can be useful in any AD&D campaign. The information on movement, cover, and encounter ranges can go a long way toward making your battles more visual and exciting. Your players will also enjoy the new tactical opportunities (and problems) this chapter presents.



Heroic Frays

The most heroic and inspirational stories of battle are about the stand of the few against the many. The legend of Roland holding the pass of Roncesvalles, or Davy

Crockett at the Alamo, or Tolkien's tale of the Fellowship standing against the orcs of Moria in Balin's tomb—these stories live forever in the imaginations of people everywhere.

In a heroic fray, the PCs are fighting against hordes of individually weak monsters such as goblins, kobolds, or giant rats. Warriors facing adversaries far less skillful than themselves can *double* their normal rate of attack. This only applies to their primary weapon; if the character is fighting with a weapon in each hand, the secondary weapon still adds only one additional attack per round. Any attacks of opportunity the heroic warrior receives must be counted off against these additional attacks, however.

In addition, warriors gain one extra attack per round

which may be used to perform a shield-punch, shield-rush, unarmed punch or kick, or grab maneuver against any opponent that they threaten when they begin resolving their attacks for the round. The normal penalties for these attacks don't apply, so the shield maneuvers don't cost the warrior his AC bonus, and the unarmed maneuvers don't provoke attacks of opportunity.

Characters can only engage in a heroic fray against creatures of 1–1 Hit Dice or less, or creatures whose Hit Dice or levels are 10 less than the hero's. A 12th-level fighter can declare a heroic fray against monsters of up to 2 HD, a 13th-level fighter can stand against 3-HD monsters, and so on.

The other requirement of a heroic fray is numbers. The hero's side must be outnumbered by the enemy for the warrior to gain his extra attacks. If there are fewer monsters left than attacks available, the excess attacks are lost.

The Battlefield



Battlefields Every fight the player characters participate in has to happen somewhere. Defining the setting for an encounter may provide players with ideas for ways to use the terrain against their enemies, or present the DM with an opportunity to make an encounter tougher by giving the monsters the same opportunities.

The Four Basic Battlefields

In most fantasy role-playing games, battles tend to take place in one of four environments: a dungeon or cave, a town or building, a castle or fortification, or outside. There are exceptions, of course, but most battles occur in one of these environments.

The DM can prepare four basic battle maps to represent each one of these areas, and then modify the map for the particular details of each new battle. For example, TSR's DRAGON STRIKE® game includes maps of a town, a meadow, a dungeon, and a cave—with a little work, the DM could use these generic maps to handle almost any fight.

Dungeons or Caves

There are three basic problems with fighting in a dungeon or cave: first, the fight usually takes place in a confined area; second, lighting may be a critical issue for characters who don't have infravision; and last but not least, the monsters usually know their own homes well. Unfortunately, most PCs end up going into dungeons or caves to confront monsters in their lairs.

Overall, dungeons or caves may be the most dangerous places to have a fight. The lighting is poor, the footing is questionable, and there are all kinds of possibilities for traps and ambushes. The cramped quarters eliminate all but the most rudimentary choices of tactics and strategy.

When preparing a dungeon battle for the PCs, the DM should note the characteristics of the area in advance. Just about anything can live in a dungeon, and almost any kind of furniture or obstacles can be found there.

Town or Building

Fighting inside buildings or in the streets of a town is almost as risky as fighting inside a dungeon. Ambush lurks around every corner, and at times it may be hard to distinguish between enemies and bystanders. Many town fights involve thieves or cutthroats who know their turf far better than the PCs, who are often visitors.

The biggest consideration in a fight in a civilized area is the possibility of help or interference from the local watch or nosy bystanders. Unless the PCs are willing to accept a price on their heads, they'll want to cooperate with the local constabulary. The DM should make a point of preparing for the arrival of the watch, since it's likely that someone will call for help before too long.

Outside

Battlefields in the great outdoors range from featureless to impassable, depending on the terrain and ground cover. From the DM's point of view, an outside battle is a difficult one to run, since there aren't many maps of forests or hillsides around. A second consideration is the possibility of long-range combat that becomes a melee, forcing a change of scale.

The battlefield generation system in the next section of this chapter deals with battlefields in all kinds of terrain. Using this system, the DM can randomly create a detailed battlefield in no time at all.

Castles or Fortifications

It doesn't take a genius to realize that storming a castle or fort of some kind is dangerous and bloody work. The defenders have the advantage of full cover and deadly traps or devices to make short work of attackers. Even high-level characters should think twice before entering the killing zones of a well-designed gatehouse or keep.

As with dungeons or buildings, the DM should prepare accurate and detailed maps, with notes about cover and trap locations, before the gaming session. This will save a lot of time during the game and eliminate the half-hour pauses in the game while the DM sets up the fight.

Battlefield Characteristics

The characteristics of a battlefield can often change the nature of an encounter by limiting movement, visibility, or missile fire. For example, charging is impossible in waist-deep water, and archery is ineffective in dense forest. Battlefields are described with six general characteristics: encounter range, lines of fire, cover, footing, obstacles, and materials or hazards that can be found there.

Encounter Range

This is the distance at which one group sights another group. The encounter range is governed by the ground cover and terrain; obviously, it's much harder to sneak up on someone on a flat plain than it is in heavy forest.

Chapter Three



Tactical encounter ranges are found in Chapter One under *Opening the Battle*.

These ranges may seem very short, but keep in mind the fact that these distances assume that both parties are trying to avoid being spotted. If one side or the other doesn't care about being seen, it's fair to double or triple the listed encounter ranges.

Note that encounter range is always the shortest of two ranges: the visibility from the surrounding terrain, and the visibility from the ambient light. A character may be able to see for miles on an open plain in daylight, but on a moonless night that open land is fairly well hidden. On a dark night in the forest, people can pass within five feet of a patient enemy without knowing that he's there.

Lines of Fire

This is related to encounter range, since terrain types that limit visibility also restrict missile fire. A battlefield's lines of fire are described as *clear*, *impaired*, or *severely impaired*. Clear lines of fire are *easy*: the battlefield has no effects on missile fire.

Impaired lines of fire have no effect on missile fire within the terrain's minimum encounter distance; for example, light forest has an encounter range of 4d6 squares, so the first 4 squares of any missile fire are unaffected. After this minimum distance, targets are treated as if they had one step of hard cover more than they actually do; a target in the open actually has 25% cover, 25% covered targets are bumped up to 50%, and so on. This is because low branches or trees are obscuring the line of fire.

Severely impaired lines of fire have no effect on fire within the terrain's minimum encounter range, similar to impaired lines of fire, above. In severely impaired lines of fire, the maximum range of any missile fire is reduced to three times the minimum encounter range, and all targets in this area gain two levels of cover.

Cover and Concealment

Most battlefields offer a fair amount of cover or concealment. This tends to be related to encounter range and lines of fire. Cover is simply described as available or unavailable; if there is cover present, its range from the character looking for cover is noted.

Footing

The ground's movement characteristics can have a drastic effect on the course of a battle. This is referred to as footing. Footing is briefly described in Chapter

One; the terrain descriptions that follow this section go into more detail on the footing for each type of battlefield.

The principal effect of poor footing is to limit movement to a fraction of normal. A character with a normal movement rate of 9 who is in heavy brush is limited to a MV of 3. The character's full-move and half-move combat actions are all affected by this limitation.

Obstacles

Assuming that the basic battlefield is a flat, barren plain, obstacles are anything that interrupt a character's movement or provide cover against missile fire. They include streams, ponds, bogs, trees, thickets, dunes or drifts, slopes or bluffs, boulders, buildings, or walls.

As noted above, obstacles have two basic effects: limiting movement and providing cover. For example, most characters have to go around a tree trunk and can stand behind it to use it for cover. If an obstacle just limits movement instead of blocking it completely, it can usually be crossed or climbed at the cost of a half-move for the character.

Unusual Materials or Hazards

This last category is a catch-all for items that just can't be described above. Some battlefields may have the makings for spears, lassoes, or slings just lying around. Other battlefields may have special hazards such as fires, quicksand, or water deep enough to drown in.

Terrain Types The following list of terrain types is not meant to be exhaustive; a book this size could be filled with descriptions of topography and ground cover for every conceivable battlefield. If you don't see something to match what you want, pick something close and approximate.

Badlands

Badlands are rocky wastes or broken terrain with jagged escarpments, deep gulches, and little plant cover. The Black Hills of South Dakota and parts of the western United States fall into this category. Rugged, knife-edged hills tend to limit vision and confine the fight to a small area.

Encounter Range: 10d8 squares (50–400 feet)

Lines of Fire: Clear

Cover: Random hard cover available within 1d6 squares of any character.

The Battlefield



Footing: Rocky slopes reduce movement by $\frac{2}{3}$; characters can move normally if they avoid climbing or descending hills.

Obstacles: Deep gulches and boulders.

Unusual: Rocks for slings are handy everywhere. Falling down a rocky slope is dangerous—if a character slips, is knocked down, or fails a Dexterity check while descending a slope, he rolls 10–40 feet (1d4×10) and suffers 1d4 damage per 10 feet fallen.

Caves

Adventurers seem to find fights in caves all the time. A typical cave is small, twisted, and dark, with uneven floors and hanging stalactites and sharp stalagmites. If the battle is taking place in a colossal cavern, it's better to consider it an open field or hillside under total darkness.

Encounter Range: By range of visibility.

Lines of fire: Impaired.

Cover: Hard cover is available within 1d3 spaces of any character.

Footing: Some cave floors may be muddy or slick, but generally footing is okay.

Obstacles: Rock formations and crevasses.

Unusual: If the lights go out, caves are pitch black. Fighting in total darkness gives the attacker a –4 penalty on attack rolls and a random chance of attacking anyone engaged with him, including friends.

Stalagmites can skewer an unfortunate character who falls on one; any character who is tripped or knocked down has a 1 in 10 chance of falling on a stalagmite. The stalagmite "attacks" with a THACO of 15 and inflicts 2d10 points of damage if it hits. A successful saving throw vs. paralyzation for half damage applies.

Desert

This is the classic sandy desert of motion picture fame. Most deserts are actually dry, rocky areas that are more like badlands or plains. The great dunes of a sandy desert tend to restrict vision and slow movement.

Encounter Range: Longest missile range.

Lines of Fire: Clear.

Cover: Available by lying behind a dune crest, but none otherwise.

Footing: Climbing a dune face reduces a character to $\frac{1}{3}$ movement.

Obstacles: Dunes block lines of sight and may shorten the encounter range. Dunes range from a couple of

feet to several hundred feet in height and may stretch for miles.

Unusual: Nothing of note.

Fields or Farmland

Vast areas of civilized nations are farmland. Usually, cultivated fields indicate a settlement, homestead or village within a mile or two. In late summer and autumn, full-grown crops such as corn or wheat may be taller than a human and provide excellent concealment.

Encounter Range: Winter/spring: long missile range. Summer or wild fields: 10d6 squares (50–300 feet); autumn: 5d6 squares (25–150 feet).

Lines of Fire: Clear.

Cover: None. Concealment is available in summer or fall by lying down.

Footing: Excellent, no penalties.

Obstacles: None.

Unusual: Nothing of note.

Forest, Heavy or Jungle

This is dark, dense forest with heavy undergrowth and closely spaced trees. The thick growth severely limits visibility and it is very easy to blunder into an enemy without ever knowing he was there. The Appalachian forests and the Pacific Northwest are good examples of heavy forest.

Encounter Range: 2d6 squares (10–60 feet)

Lines of Fire: Severely impaired.

Cover: Hard cover within 1d3 squares of any character; concealment within 1d3–1 squares of any character.

Footing: Heavy undergrowth and close-set trees reduce all movement by $\frac{1}{3}$.

Obstacles: Trees and thickets.

Unusual: A ready supply of branches can provide clubs or sharpened stakes in no time at all. In some forests, heavy vines can be used for snares or lassoes.

It's dangerous to ride at high speed in a forest; the rider of any mount moving at a run or gallop has a 1 in 6 chance per turn of being struck by a branch. The rider must roll a successful saving throw vs. paralyzation or be unhorsed, suffering 1d6 points of damage in the process.

Dense forests severely restrict flying creatures of Size L or bigger. Such monsters must land in a clear area and approach their prey on the ground, since there is not enough space between the trees to unfurl their wings.

Chapter Three

Forest, Light

The principal difference between heavy forest and light forest is the amount of underbrush. Light forests have much less brush to obstruct movement on the ground, and tend to be much airier and brighter. Small stands of trees, copses, or orchards can all be considered light forest.

The ground level of a true rain forest can also be considered light forest, since there is little underbrush and the trees are spaced a fair distance apart. The canopy levels might be considered thickets or dense forest.

Encounter Range: 4d6 squares (20–120 feet)

Lines of Fire: Impaired.

Cover: Hard cover available within 1d6 squares of any character; concealment available within 1d4 squares.

Footing: Normal.

Obstacles: Trees.

Unusual: See heavy forest.

Hills

Most hills are considered to be part of another terrain. For example, gentle rolling hills are plains, forests, or farmlands—their ground cover is their most important characteristic. This category actually refers to rugged foothills or highlands with light or no forestation. Large areas of the Appalachian mountains, the Scottish Highlands, and the foothills of the Alps fall into this category.

Encounter Range: Determined by the level of forestation (heavy, light, or none.)

Lines of Fire: Determined by the level of forestation.

Cover: Determined by the forestation, but in hills with no trees, hard cover is still available within 2d10 spaces of any character.

Footing: Characters moving uphill are slowed to $\frac{2}{3}$ or $\frac{1}{2}$ movement, depending on the severity of the grade. The forestation may limit movement even if the grade isn't too bad. Characters who slip or fall while moving downhill must roll a successful saving throw vs. death or roll 10–40 feet (1d4×10), suffering 1d4 damage per 10 feet fallen.

Obstacles: Boulders, escarpments, and ravines or gulches.

Unusual: Characters fighting with a height advantage (i.e., attacking from uphill) gain a +1 bonus to their attack rolls. Most hills are good places to find rocks for slingstones.

Marsh

Marshes aren't swamps; marshes are bogs or wetlands without trees. The ground is treacherous, and careless adventurers can easily become lost or mired in mud. Marshes may be flat, but tall stands of reeds can serve as excellent concealment, and characters who don't mind getting wet can always go to ground to stay out of sight.

Encounter Range: 4d12 squares (20–240 feet)

Lines of Fire: Clear.

Cover: None. A character can find concealment within 2d6 squares behind reeds or in shallow ponds or creeks.

Footing: In knee-deep water, characters move at $\frac{3}{4}$ their normal rate. In waist-deep water, they move at $\frac{1}{2}$ their normal rate. In shoulder-deep water, movement is reduced to $\frac{1}{3}$ normal.

Obstacles: Ponds, creeks, and streams.

Unusual: Characters grappling in water waist-deep or deeper can try to drown their opponent if they achieve a hold on him. The victim is considered to begin holding his breath on the round in which his attacker got his wrestling hold, and may begin to drown as described in the *Player's Handbook*, Chapter 14: Time and Movement, under Holding Your Breath.

Note that characters rendered unconscious by an attack may also be in danger of drowning if they fall into water of any depth.

Mountains

Battles on actual mountainsides are rare. This type of terrain represents high passes, canyon-walls, deep valleys, high snowfields, and windswept peaks. If the fight takes place below the treeline, consider the terrain to be hills, forest, or fields.

Encounter Range: Long missile range.

Lines of Fire: Clear.

Cover: Hard cover is usually available within 3d10 squares of a character, but it may take mountaineering skills to get to it.

Footing: Characters moving uphill or downhill are reduced to $\frac{1}{2}$ normal movement or possibly stopped altogether, depending on the grade. If no normal movement is possible, characters may decide to climb instead.

Obstacles: Boulders, ice or snow, cliffs, dangerous slopes.

Unusual: Characters who slip or fall while climbing or moving downhill must roll a successful saving throw vs. death or fall 10–60 feet (1d6×10), suffering 1d6 points of damage per 10 feet fallen. Mountainsides usually have a plentiful supply of rocks of all sizes.

The Battlefield



Plains

Open plains are a tactician's greatest challenge. Without any clear advantage to be gained from controlling a terrain feature, battles become contests of maneuver and skill. Any commander can stand off a superior enemy force in rough terrain, but it takes a genius to defeat the same force on open ground. Plains include savannahs, dry steppes, and some grassy deserts as well as American Midwest-style prairie.

Encounter Range: Long missile range. A Man-sized creature can be spotted as far as 1,000 yards away on level plains.

Lines of Fire: Clear.

Cover: None.

Footing: Normal.

Obstacles: The random stream, gulch, or stand of trees.
Unusual: Nothing of note.

Ships

In many AD&D campaigns, ships and boats are the fastest way to travel long distances. Many kingdoms rely extensively on sea trade and are plagued by pirates or privateers. Naturally, adventurers tend to get involved in problems like this. Fighting on a ship first assumes that the attacker can catch and board his prey.

Encounter Range: Belowdecks, encounter range is limited by the range of vision. Abovedecks, everything is in range for an encounter. Ships can spot other ships as far as 10–15 miles away, depending on their size and the prevailing visibility.



Chapter Three



Lines of Fire: Impaired.

Cover: Masts, deckhouses, water-kegs, and gunwhales can all function as hard cover. Abovedecks, any character is within 1d4 squares of hard cover.

Footing: Normal. Climbing around in rigging is a different matter, though.

Obstacles: Masts, sails, deck cargo, and open hatches can obstruct movement.

Unusual: The sails and masts of a ship are known as its rigging. Moving around in the rigging is treated like climbing, but there are always ropes or ladders handy. If a character in the rigging slips or is knocked down, he may fall to the deck or the sea.

Swamp

Swamps are like marshes, but have trees and thickets. Most of a swamp's trees can be found on islands of solid ground, but many others (such as cypresses) can thrive in the water. The Louisiana bayou, the Great Dismal Swamp of Virginia, and portions of the Everglades are good examples of swamps.

Encounter Range: 2d6 squares (10–60 feet)

Lines of Fire: Impaired.

Cover: Hard cover is available within 1d6 squares of any character. Concealment is available anywhere, by going to ground.

Footing: In knee-deep water, characters move at $\frac{2}{3}$ their normal rate. In waist-deep water, they move at $\frac{1}{2}$ their normal rate. In shoulder-deep water, movement is reduced to $\frac{1}{3}$ normal.

Obstacles: Trees, thickets, bogs, creeks, ponds, quicksand.

Unusual: See Marshes. In addition, swamps usually have wood or vines handy, which can be used to make improvised weapons.

Taverns

It seems to be the fate of adventurers everywhere to get into brawls and scrapes of the nastiest sort in alehouses and common rooms. The typical indoors fight is a dangerous and bloody affair, complicated by the presence of bystanders and the possible intervention of the town watch.

Encounter Range: By limit of visibility. Naturally, you can't fight with someone who isn't in the room.

Lines of Fire: Usually impaired.

Cover: Tables, benches, and furniture can all be used for hard cover.

Footing: Normal.

Obstacles: Furniture.

Unusual: Chairs, mugs, bottles, and other tavern accessories can all be used as clubs or other weapons.

Town Streets

If the PCs aren't getting into barroom brawls, they're probably fighting in the alleys or streets right outside. Most medieval towns had very close-spaced buildings with dark, winding streets.

Encounter Range: 2d6 squares (10–60 feet)

Lines of Fire: Usually clear.

Cover: Hard cover is available within 1d6 squares of any character.

Footing: Normal.

Obstacles: Carts, wagons, vendor's stalls, passers-by, buildings.

Unusual: Walls and gatehouses often limited movement between sections of a town. These areas could be used as strongpoints by a defending force. Almost any kind of weapon materials may be close at hand in a typical town street.

Generating a Battlefield

Since the PLAYER'S OPTION combat system relies on a figure's positioning and facing, any battlefield the DM creates

should show obstacles and terrain features in the exact squares they occupy. The following section describes a quick battlefield generation system that the DM can use when he doesn't have the time or forewarning to prepare a detailed battlefield before the player characters get into a fight.

This system should not replace old-fashioned preparation for an adventure. If you know that the players are likely to encounter a troll ambush in a mountain pass, make some notes about the setting of the battle before the adventure begins. Any staged encounters in buildings should be described, too. If you take the time to draw a good dungeon map, the map can be copied to a larger size for use with the PLAYER'S OPTION combat system without too much trouble.

The only times you should have to create a battlefield from scratch are when you don't expect a fight to occur, such as when the PCs run into a random encounter while traveling cross-country or pick a fight with someone they were just supposed to talk to. Save yourself the trouble of creating a battlefield if it is fairly obvious that the encounter won't lead to a fight or if it seems likely that the actual fight will be very short.

The Battlefield



Step One: Scale

Here's a tip for saving time: don't make a battlefield bigger than it has to be. There's no point in mapping every street of a town if you're confident that you can contain the battle in one dark alleyway. Refer to the encounter ranges listed for the various terrain types in the previous section; you probably don't need to make the battlefield bigger than about 125% to 150% of the maximum encounter range. For example, in light forest, the encounter range is 4d6 squares. The maximum encounter range is 24 squares, so you'll want a battlefield about 30 to 35 squares across. If the encounter is taking place indoors, it's not necessary to map out more than the room the PCs are fighting in.

Step Two: Topography

Take your battlefield and divide it into nine sections, like a tic-tac-toe board. The lay of the land may place some parts of the battlefield higher than the other parts. Each of these nine sections is assigned a height relative to the others; from these different heights, you'll derive the slopes of your battlefield. (If this is an indoors fight, ignore this step.)

First, determine the base topography for your battlefield: flat, hilly, or broken. Marshes, swamps, plains, and some fields and forests are flat; hills, deserts, and most other fields and forests are hilly; and badlands, caves, some deserts, and mountains are broken.

Diagram 12: Topography

Area 6 is a level 2 hill, which elevates areas 3, 5, and 9 and half of areas 2 and 8 to level 1.

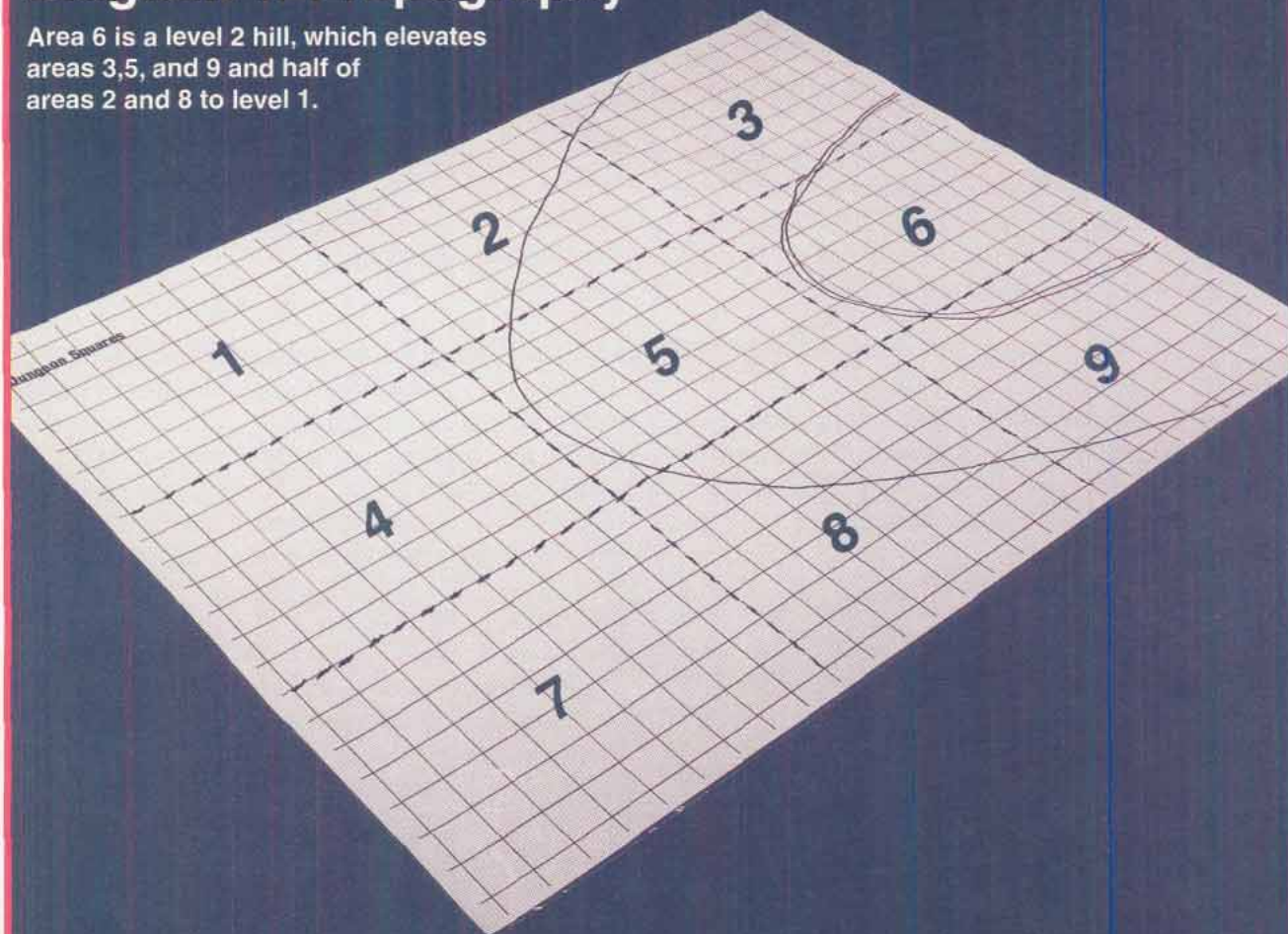

Chapter Three



Flat

No slopes or elevations worth noting. You're done with this step.

Hilly

Roll a d6 for each section of the battlefield; on a 1, that section is elevated 20 feet above the rest of the battlefield, and all adjacent sections are elevated 10 feet above the base height. On a roll of 2, that section is elevated 10 feet above the base height.

Broken

Roll a d6 for each section of the battlefield; on a 1, that section is elevated 20 feet, but adjacent areas aren't elevated as they are in hilly terrain. On a 2 or 3, that section is elevated 10 feet.

Slopes and Escarpments

Hills are surrounded by slopes. Each 10 feet of elevation requires a slope of two to four squares to surround it. Draw a hilltop of three to ten squares at the midpoint of each elevated area, and then circle the hilltop with a ring of sloping squares.

Broken areas may be surrounded by slopes or escarpments. Any side of an elevated area has a 50% chance of being either a slope or an escarpment. If it is a slope, draw it as described above. If it is an escarpment, consider it to be one square wide.

Step Three: Ground Cover and Water

Now, take each section of the map and determine how dense the ground cover is in that area. The categories are clear (C), thickets or brambles (T), light woods (L), and heavy woods (H). Roll a d6 for each area and consult the chart below:

	1	2	3	4	5	6
Light Woods	C	C	T	L	L	H
Heavy Woods	C	T	L	H	H	H
Swamp	C	C	T	T	L	L
Hills	C	C	C	C	T	L
Plains	C	C	C	C	C	T

Clear

No ground cover in that section of the battlefield.

Thickets

Brambles or thickets cover that section of the battlefield. Thickets tend to be in clumps; take about two-

thirds of the squares in that area and mark a couple of bramble patches.

Light Woods

Light forest is prevalent in that area of the battlefield. Trees are about three squares away from each other; mark trees in about one-quarter of the squares in that section.

Heavy Woods

Heavy woods are like light woods, but the trees are closer together. Mark trees in about one-third to one-half of the squares in that area, about one to two squares away from each other.

Standing water or bogs can be handled in much the same way as ground cover. Each section of a marsh, swamp, field, or plain may be clear (C), or it may have a pond (P), bog (B), or stream (S) in it. Roll 1d6 for each ninth of the map:

	1	2	3	4	5	6
Marsh	C	S	B	B	P	P
Swamp	C	S	B	B	B	P
Field	C	C	C	C	S	P
Plain	C	C	C	C	C	S

Clear

No water in that region.

Bog

About one-half of the area in question is a soft, muddy bog. Bogs are usually knee-deep to shoulder-deep water, with lots of vegetation, mud, and debris. Bogs tend to be one large bog, and not many smaller bogs, so mark only one or two distinct bogs per area of the map. If two adjacent areas have a bog, they might be one larger bog. Consider connecting them together.

Stream

Most streams are only one or two squares wide, and range from knee-deep to shoulder-deep. Streams don't usually appear and disappear without a body of water to flow into or out of, so make sure that the stream squares form a continuous line and go somewhere if at all possible.

Pond

About three-quarters to all of the area is under water. Ponds are usually knee-deep or waist-deep near the edges, but can be 10 or 15 feet deep in the middle.

The Battlefield



Step Four: Obstacles

Battlefields are often littered with obstacles and obstructions. They provide cover, limit movement, and occasionally endanger the people fighting around them. The DM should arbitrarily scatter a handful of obstacles of his choice over the map. Obstacles include:

- Gulches, ravines, or ditches (any terrain except marsh or swamp)
- Boulders (hills, mountains, badlands)
- Rockfalls (hills, mountains, badlands)
- Deadfalls (forests, swamp)
- Fences, earthworks, or buildings (any civilized area)

Step Five: Putting It All Together

Your battlefield should now be complete. Chances are, you have some defensible terrain and some open areas that invite attack. Now, the DM should decide where each force starts. If one side surprises the other, the surprised fellows have to set up first, and the surprising force gets to set up around them. If one side was stationary or defending, they set up along one randomly-determined map edge, and the attackers set up opposite them.

If both forces were moving, roll randomly to see which edge of the mapboard each force was coming from. They can enter the encounter area from adjacent sides of the battle map, but not from the same side. If the players have a set marching order, the DM can insist that they set up their figures accordingly. Or, if the circumstances dictate, he can allow them to place their figures wherever they see fit.

Please note that the simple creation of a battlefield does not guarantee a more exciting and interesting encounter—the DM has to reward characters who use their heads by making use of the terrain, and present the party with enemies who do the same. Even a grizzled party of adventurers should think twice before going up a rocky hillside against a band of orcs who can see them coming.

Fighting in Unusual Conditions

Since adventures are notoriously unpredictable, a surprising number of battles take place in the most inconvenient places. Player characters tend to get into fights while hanging on the side of a cliff, swimming in subterranean lakes, or while ventur-

ing into fantastic planes of existence. Last but not least, many magical spells can create strange effects. This next section addresses the most common of these unusual conditions.

Limited Visibility

Fighting at night or in dark settings is difficult—especially if your foe can see better than you can. As noted in the *DMG*, characters fighting in darkness or heavy fog suffer penalties to their attack rolls, damage bonuses, and Armor Classes.

Moonlight or Moderate Fog or Rain

Characters suffer a -1 penalty to attack rolls and saving throws. Since nothing can be seen more than 100 yards (60 squares) away, spell and missile ranges are limited; no missile scale combat can take place in an encounter.

Starlight or Dense Fog or Heavy Rain

Characters suffer a -3 to attack rolls and saving throws, a -2 penalty to AC, and only get $\frac{1}{2}$ their normal damage bonus for exceptional Strength. Nothing can be seen more than 50 yards away (10 yards for dense fog or cloudy moonless nights), so spell and missile ranges are very limited.

Total Darkness

Characters suffer a -4 penalty to attacks, saves, and AC and receive no damage bonus for exceptional strength. No special attacks such as disarms, backstabs, or traps are allowed—the character can't see his own weapon, let alone his target.

Water

Underwater combat is described in some detail in the *DMG*. Here's a quick reminder of some of the difficulties of underwater combat.

Weapon Restrictions

Only type P weapons can be used effectively underwater; the water offers too much resistance to use any other kind of weapon except nets.

Vision

Under the best of circumstances, characters can see no more than 100 feet underwater (50 feet in fresh water.) For each 10 feet they descend, this range of

Chapter Three



vision is reduced by 10 feet; if a character is 30 feet underneath the surface of a lake, he can only see 20 feet. If it is dark outside or the water is muddy, this could be reduced even more.

Movement

Characters moving about underwater have to swim. See Swimming under Chapter 14: Time and Movement in the *Player's Handbook*.

Characters who are only wading are much less affected. Wading in knee-deep water reduces movement by $\frac{1}{2}$. Wading in waist-deep water reduces movement by $\frac{1}{2}$ and adds a one-phase initiative penalty to any action the character takes. Wading in shoulder-deep water reduces movement by $\frac{2}{3}$, adds a two-phase penalty, and causes the character to lose any Dexterity adjustment to his Armor Class (although it does provide cover against someone firing missiles at the character).

Fighting Underwater Monsters From the Surface

It's always great fun when a wading character gets attacked by some aquatic horror. When a character fights against something that uses water for cover, slashing and bludgeoning weapons are useless. Only type P weapons can be used to attack underwater creatures, and there is a -2 penalty to hit. The wading character also loses any Dexterity adjustment to AC when attacked from beneath the surface.

Climbing

Cliffs and mountaintops are another awkward place for a fight. Adventurers seem to be drawn to the worst locations imaginable for their heroic battles and often find themselves under attack while they're clinging to a vertical wall of rock.

Movement

Climbing characters normally move 1 foot per round for each point of normal movement. A dwarf with an adjusted movement rate of 5 can climb 5 feet per round in good conditions. Refer to Climbing under Chapter 14: Time and Movement in the *Player's Handbook*.

Fighting

Climbing characters lose all AC bonuses for Dexterity and shield, and may have rear attack modifiers applied against them. They have a -2 penalty to attack, damage, and saving throw rolls. If a character is above his enemy, he gains a $+2$ bonus on his attack rolls; if he is

beneath his enemy, he suffers an additional -2 penalty.

Any time a character is struck while climbing, she must make a climbing check, detailed in Chapter 14: Time and Movement in the *PHB*. Note: you can use a default check of 30% in good conditions.

Fighting Flying Creatures

Encountering angry giant eagles while clinging to a cliff is usually no fun at all. Unless they can hover, flying monsters can only make one pass every other round to attack climbing characters. If the PCs are facing the cliff (most climbers have to), the flying creatures get the benefit of rear attacks. Intelligent flyers may try to use their talons to drag a climber off the cliff; treat this as a grab attack. This forces a climbing check, and even if the character succeeds, he still must win the Strength contest to stay on the cliff side.

Aerial Combat

Aerial combat is described at length in Chapter 9: Combat under the optional rule Aerial Combat in the *DUNGEON MASTER Guide*. Here's the gist of how these rules work in the *PLAYER'S OPTION* combat system.

Initiative

The more maneuverable flyer gains a -1 bonus to its initiative roll for each level of difference in Maneuverability Class between itself and its opponent. Creatures at home in the air have an easier time fighting while airborne.

Threatening

No aerial combatant threatens any adjacent creatures. Combat in the air just doesn't work that way; battles tend to take the form of joust-like passes at each other.

Movement

All fliers with a MC of B or worse must declare a half-move action every round just to stay in the air. Class B fliers can hover in position, but fliers with a MC of C or worse must move forward in this half-move to stay aloft. This requirement to keep moving means that a class C flier can make an attack against a stationary target once per two rounds, a class D flier once per three rounds, and a class E flier once per six rounds.

Gaining a point of altitude costs an additional movement point; a flier with a move of 18 could move 9 squares forward and 9 squares up with a full-move

The Battlefield



action. Diving allows the flier to add one point of free movement for each point of altitude it drops, so the flier with the 18 movement could move 36 squares in a full-move dive. Of course, it also has to drop 18 points of altitude (90 feet) to do this.

Attacks from Below

Creatures attacking from beneath an opponent cannot charge, but they may be in a blind spot. The defender can reply with an attack only if it has natural weapons or its rider is equipped with a size L weapon, such as a lance.

Attacks from Above

Creatures attacking from above may declare a charge by diving at their victims. Lances, spears, and a flier's natural talons or claws inflict double damage in a dive attack. In addition, the defender may not be able to reply to the attack if its only natural weapons are talons or hooves.

Unseating a Rider

Characters riding a flying mount can be "unhorsed," just like characters on the ground. If the character is strapped into his saddle (a wise precaution), he is simply knocked off-balance in his seat and suffers the same penalties as if he had actually been knocked down on the ground—he is easier to hit and has to spend an action getting back in his seat.

Naturally, if a character is not strapped in, he risks the damage of a fall if he is unseated by any means.

Combat on Other Planes

Almost any conditions imaginable may be encountered in the various planes of existence. The PLANESCAPE™ campaign setting describes the general conditions of the various Outer and Inner Planes, but fights are also likely to occur in two other settings: the Astral and the Ethereal Planes.

Astral Combat

On the Astral Plane, a creature's tactical movement is based on its Intel-

ligence score. Its move becomes 30 feet (6 squares) per point of Intelligence. In addition, Intelligence replaces Strength for purposes of determining attack and damage adjustments, and Wisdom replaces Dexterity for AC adjustments and missile fire. All missile ranges are doubled, but non-native characters suffer a -2 penalty to hit with missile attacks.

There are very few obstructions in the Astral Plane, and the encounter range is normally twice the longest missile range. Since this is most likely a great distance, astral combat should be run in missile scale. Fighting in the Astral is like aerial combat; creatures do not threaten each other, and can move in three dimensions.

If a character's astral self is killed, she immediately returns to her physical body with only 1 hit point. If the character is killed while physically on the plane, she is dead.



Chapter Three

Ethereal Combat

Ethereal creatures move at their normal unencumbered rate, regardless of their equipment and armor. Unlike the Astral Plane, the Ethereal is a swirling mass of misty proto-matter that obscures vision; the Encounter Range is 10–40 squares (50–200 feet). Missiles tend to be slowed by the misty matter, and shots of medium range or longer just stop and hang in the air.

If a character is in the Border Ethereal, she can still perceive the shadowy outlines of the plane she just left. She can move through any objects or creatures without impediment. Of course, she is unable to affect things on the plane she is viewing, but she can only be affected by the magical gazes of a very limited number of monsters.

The Effects of Magic on the Battlefield

Needless to say, the one thing that breaks all the rules on a battlefield is magic. Spells and magical items can create almost any condition imaginable, ranging from the merely annoying to the truly catastrophic. We could spend most of this book describing the exact effect of each and every spell and magical item in the game system, but this wouldn't be very practical. Instead, we'll discuss the most common effects that may give DMs trouble.

Wizard Spells

The most powerful and effective spells in the AD&D game are found in the hands of wizards. In fantasy role-playing, wizards often dominate battlefields like heavy artillery or airstrikes in modern warfare. Entire battles often hinge on one character's choice of spells and the enemy's attempts to down the wizard before he wreaks havoc on them.

Blink

The spell *blink* works slightly differently in the PLAYER'S OPTION combat system. Roll 1d6; on a 1, the wizard blinks in the very fast phase, on a 2, fast, on a 3 or 4, average, on a 5, slow, and on a 6, very slow. The wizard's blink always occurs first in the phase, before any other actions are resolved.

Darkness, 15' Radius

Creatures outside the area of darkness cannot trace a line of fire through the darkness to a target on the other side. Creatures moving in total darkness are reduced to $\frac{1}{2}$ their normal move unless they wish to risk stumbling

Enlarge

A character who grows to eight feet in height becomes size Large; a character who grows to 12 feet in height becomes size Huge. This affects reach, threatening, and moving through smaller figures; see Chapter One. Very large monsters can be made smaller by applying the reverse of this spell.

Fog Cloud

As with *darkness*, magical fog blocks any lines of fire. Creatures blundering through the fog can easily be ambushed by enemies waiting for them to come into the open; the DM can insist on surprise checks if he deems it appropriate.

Hallucinatory Terrain

This spell is very dangerous when used to conceal hazardous areas. If the victims do not perceive the illusion, they fall prey to whatever hazards the terrain holds. For example, creatures who run down a hillside believing it to be level ground receive no Dexterity check or saving throw to keep their balance; they automatically fall and roll or slide to the bottom of the hill.

Haste

Creatures under the influence of a *haste* spell increase their base initiative and weapon speeds by two phases and always win initiative. Their movement rates are doubled, and they gain a second set of attacks in the very slow phase.

Invisibility

The best thing to do with an invisible character or monster in a fight is to secretly note its location each round and physically remove the figure from the board. Do yourself a favor and don't run combats with invisible figures on both sides.

Jump

The creature empowered by this spell can actually leap over Man-sized targets without provoking an attack of opportunity. In addition, if the jumper wins initiative, he can make a half-move action to leap away after he attacks an adjacent figure, whether or not he is threatened by his enemy.

Pyrotechnics

The smoke effect of this spell blocks lines of sight and hinders missile fire just like magical mists or fogs.

The Battlefield



Shocking Grasp

At the DM's option, creatures in metal armor may be considered AC 10 versus the wizard's touch. Only Dexterity and magical adjustments apply.

Slow

Creatures affected by a *slow* spell automatically lose initiative and reduce their base initiative and weapon speeds by two phases. As noted in the spell description, their movement rates and attack rates are halved.

Priest Spells

Few priest spells in the *Player's Handbook* that do not duplicate wizard's spells actually affect the battlefield to any significant degree. However, the *Tome of Magic* includes a number of priest spells in the sphere of war designed for the battlefield.

Air Walk

Creatures affected by an *air walk* spell move and fight as if they were on solid ground as opposed to engaging in true aerial combat. They threaten squares in front of them and can guard against the attacks of other flying creatures, gaining the advantages of that combat action.

Obscurement

Like magical *fog*, *obscurement* blocks lines of sight through the affected area, screening creatures in or behind the mists from most missile attacks.

Magical Items

There are hundreds of magical items that can create various effects on the battlefield. The exact results of a magical item's use are left to the DM's discretion, but here are some general guidelines on some specific items. In cases where a magical item duplicates a spell effect, refer the spell sections.

Potion of Growth

Characters may easily change size by imbibing a *potion of growth*; they gain the advantages of extended reach and size bonuses in overbearing or overruns as normal for monsters of that size.

Potion of Invulnerability

The imbiber can still be knocked down, grappled, or overborne by creatures he is otherwise immune to.

Apparatus of Kwalish

The mechanical claw attacks of the *apparatus* act in the slow phase of initiative.

Boots of Speed

The Armor Class bonus applies when the character chooses a half-move or full-move combat action. Going toe-to-toe in a melee doesn't allow the wearer of the *boots* to take advantage of their defensive properties, although he can always use the extra movement.

Boots of Striding and Springing

If the wearer strikes before his enemy because of a better action speed or because he won initiative, he may spring away as described in the *DMG* without provoking an attack of opportunity. The +1 AC bonus applies all the time, even when the user is mired in a stationary slugging match.

Crossbow of Accuracy

Although the weapon treats all shots as short range, it still has medium and long ranges for purposes of armor penetration. See crossbows in Chapter Seven: Weapons and Armor.

Scimitar of Speed

The *scimitar of speed* is very fast, and its wielder always wins initiative if he declares a combat action that involves an attack with the weapon.

Short Sword of Quickness

See *scimitar of speed*, above. If two such weapons are involved in a single battle, their strikes are considered to be simultaneous.

Sword of Sharpness

The magical properties of *sharpness* override the normal critical hit procedure. It is still possible to achieve a normal critical hit by rolling an 18 or 19, even if it doesn't quite activate the *sharpness* properties. If a limb is severed, consider the injury to be a critical one of the appropriate sort—Chapter Six details the unpleasant effects of losing limbs.

Vorpal Sword

As with the *sword of sharpness*, the properties of a *vorpal blade* override the critical hit procedure. If the wielder rolls an 18 or higher that meets the criteria for a critical hit without invoking the vorpal power, a normal critical hit results.

Chapter Four: Weapon Specialization & Mastery



In a desperate battle, the only thing that stands between a brave hero and a grisly end is his skill with blade or shield. Skill at personal combat is a valuable commodity in a fantasy setting; it's hard to imagine Conan meeting his better at swordplay, or the Gray Mouser encountering a foe swifter and more agile than himself.

This chapter describes a revised weapon proficiency system that includes several grades of specialization as well as new uses for a weapon proficiency. This material is completely compatible with the character point proficiency system described in the *Skills & Powers* book; the point system allows characters to purchase proficiency, expertise, specialization, or mastery in the same way that an AD&D character can spend proficiency slots to gain these benefits.

A number of new uses for weapon proficiencies are also included in this chapter. Weapon groups, fighting styles, attack maneuvers, shield use, armor use, special talents, and dirty tricks can all be learned by spending weapon proficiency slots.

Weapon Proficiencies Anybody can pick up a sword and swing it in a menacing manner, but without proper training and technique it's impossible to use a weapon correctly. A character's weapon proficiencies represent weapons in which he has some degree of training. Usually, he can wield them without embarrassing himself.

Weapon Specialization & Mastery



Intelligence and Proficiencies

Fighters, paladins, and rangers may apply their bonus language slots for high Intelligence scores to any kind of weapon proficiency. Characters of any other type can only use these extra proficiency slots to learn nonweapon proficiencies. This rewards fighters who chose brains over brawn by allowing them to compensate for shortcomings in physical attributes with the benefits of skill and training.

Under this rule, the character's number of allowed languages simply represents the most languages she can ever learn. The character isn't assumed to begin play knowing any extra languages; instead, she must use non-weapon proficiency slots to learn any extra languages she wants to speak. Characters can always speak their native tongue without spending any proficiency slots.

Demihuman characters who are allowed to learn extra languages still have to spend slots learning these tongues. Their advantage lies in the fact that they can begin play with knowledge of these languages, because they had access to people who spoke them when they were growing up.

Proficiencies and the Skills & Powers Book

The PLAYER'S OPTION character point system replaces the normal acquisition of proficiency slots. Characters may decide to learn a lot of skills by devoting their character points to a variety of proficiencies, or they may choose to specialize in a few areas. Regardless of how they elect to spend their character points, the end results are the same: either they have a proficiency in something or they don't.

Weapon Groups

Many weapons are very similar in construction and techniques of use; for example, using a bastard sword with one hand is not too much different from using a long sword. Both weapons are heavy, two-edged blades that rely on slashing or chopping strokes to cut through armor. All weapons are categorized in *tight groups*, which are further organized into *broad groups*. The particular group a weapon belongs to is noted under the weapon characteristics in Chapter Seven.

Tight groups serve two functions in game play. First of all, all weapons in a tight group are considered to be *related* to each other. A character who is proficient in

one weapon belonging to a tight group is automatically familiar with the other weapons of that tight group and has a reduced penalty for nonproficiency when using them.

Second, characters can learn to use all weapons in a tight group with a *weapon group proficiency*. Weapon group proficiencies cost two slots, but may include a number of weapons. For example, a character could use a weapon group proficiency to gain proficiency in crossbows; by spending two slots, he actually gains proficiency in six different weapons.

Some tight weapon groups are further organized into broad groups. For example, the tight groups of axes, picks, hammers, and maces are all part of the hafted weapon broad group. Proficiency in all of the weapons of a broad weapon group can be learned for three proficiency slots.

A number of weapons are completely unrelated to anything else. For example, lassoes just don't work like any other type of weapon. The same applies for nets, whips, bolas, and mancatchers. These weapons must be learned one at a time.

Specialization and Weapon Groups

Having a weapon group proficiency counts as the first slot of specialization for *one* weapon in that group. When the character chooses to specialize, he need only spend one additional proficiency slot and select any weapon of that group as his specialty. For example, a character with the crossbow tight group proficiency could spend one additional slot to specialize in the medium crossbow. He's spent a total of three slots but has proficiency with six types of crossbows and specialization with his preferred weapon, the medium crossbow.

Character Classes and Weapon Proficiencies

Most character classes are limited in their selection of weapons. However, in the *Skills & Powers* book, a character may choose to be proficient in a weapon she normally would not be allowed to use. This is reflected by requiring the character to spend more character points than normal to become proficient.

As an optional rule, characters may learn to use barred weapons by paying extra proficiency slots. A rogue or priest may learn a weapon normally reserved for warriors by suffering a one-slot penalty, and wizards may learn weapons normally reserved for priests or rogues with a one-slot penalty. If a wizard wishes to

Chapter Four



learn the use of a weapon normally reserved for warriors only, she must pay a two-slot penalty. For example, a wizard who wants to use a long sword could do so by paying two weapon proficiencies for it, since long swords are available for rogues—but she would have to pay three slots to become proficient in the two-handed sword.

Note that the limited number of weapon proficiencies available for nonwarrior characters will tend to control character abuse of this rule. Priests may be *capable* of learning any weapons under these rules, but priests who use barred weapons do so at the risk of angering their superiors or deity.

Kits and Barred Weapons

Some kits may allow characters to use barred weapons; for example, militant wizards may select a sword as one of their weapon proficiencies. Generally, the bonuses and perks of a kit are considered to negate any out-of-class penalties. However, priests may still be limited by their priesthood weapon restrictions.

New Weapons

A number of new weapons are introduced in Chapter Seven: Weapons and Armor. Many of these are similar to weapons that were restricted in the *Player's Handbook*. The Weapon Table in Chapter Seven lists any classes that cannot use a particular weapon under normal circumstances.

Shield Proficiency

By spending a weapon proficiency, characters can become more skilled in the use of their shield. Modern reenactments of medieval tournaments have demonstrated that the shield is a very important part of a warrior's protection. The extra protection conferred by the shield varies by the exact type the character becomes proficient in:

Shield Type	Normal AC bonus	Proficient AC bonus	Number of Attackers
Buckler	+1	+1	1
Small	+1	+2	2
Medium	+1	+3	3
Body	+1/+2 vs. missiles	+3/+4 vs. missiles	4

The number of attackers is the maximum number of times the shield bonus can be used in a single round

by the character. Normally, shields can only be used against enemies in the character's front spaces or in the flank spaces on the character's shield side.

Armor Proficiency

Similarly, characters can spend time and effort learning how to use their armor more efficiently. While this doesn't provide a bonus to Armor Class, it can help to offset the hefty encumbrance penalties of heavy armor. A character who spends a weapon proficiency slot becoming acquainted with a type of armor gains the special benefit of only suffering one-half the normal encumbrance of that armor.

For example, chain mail normally weighs 40 pounds, but a character with a proficiency in chain mail only has to count 20 of this towards his encumbrance level. This represents the character's training in wearing the armor just the right way and his practice in moving around while wearing 30 or 40 pounds of ironmongery.

Weapon Mastery

It's fairly obvious that there is a huge difference in the attack potential of an unskilled novice and a trained swordsman. The level of skill with which a character fights is divided into six general categories: nonproficiency, familiarity, proficiency, expertise, specialization, and mastery.

Skills & Powers uses character points to acquire each level of mastery, but this system is also compatible with AD&D weapon proficiencies. Nonproficiency and familiarity have no cost in proficiency slots, normal proficiency costs one slot, expertise and specialization cost two slots, and mastery costs three or more slots.

Nonproficiency

If a character has never had any training or practice with a weapon, he is nonproficient. He can only guess at the proper way to hold the weapon or attack his opponent. Anything fancier than a simple hack, slash, or bash is beyond his abilities—the character cannot attempt any attack options such as disarming, blocking, or sapping.

In addition to his inability to make special attacks, the character also suffers an attack roll penalty based on his character class. Warriors tend to figure out weapons of any kind relatively quickly and have a small penalty for attacking with weapons they're not familiar with. Other characters don't have the warrior's affinity for weapons and are more severely penalized. These penalties are:

Weapon Specialization & Mastery

Class	Nonprof.	Familiarity
Warrior	-2	-1
Wizard	-5	-3
Priest	-3	-2
Rogue	-3	-2
Psionicist	-4	-2
Nonclassed NPCs	-4	-2

Any weapon wielded by a non-proficient character is considered one initiative phase slower than it really is, and missile weapons have their rate of fire halved. An untrained character wielding a long sword has an initiative phase of slow, not average, and an unskilled character wielding a long bow would only fire once per round instead of twice.

Familiarity

All characters are automatically *familiar* with any weapon that is related to a weapon they are proficient in. Weapons are considered to be related if they are part of the same tight group. For example, a character who is proficient in the use of the light crossbow is automatically familiar with all other types of crossbow because they're part of the same tight weapon group.

Familiarity is not as good as proficiency, but it beats not knowing anything about a weapon at all. Characters only suffer one-half the normal nonproficiency penalty when attacking with weapons they are familiar with. They may attempt any normal attack maneuvers possible (the familiarity penalty still applies, of course), and suffer no initiative or rate of fire penalties.

Familiarity does *not* allow the user to make use of any special weapon attack modes that require proficiency in the weapon.



Chapter Four



Proficiency

This is the basic level of competence most characters achieve with their weapons training. Proficiency allows the character to use a weapon with no penalties and employ all attack options and special weapon properties to their fullest extent.

As noted previously, warriors can spend two proficiency slots to become proficient in a tight weapon group, or three slots to become proficient in a broad group. Otherwise, characters have to spend one slot per weapon they wish to be proficient with.

Expertise

Weapon expertise is a form of specialization that is available to nonfighters. Regular weapon specialization (described below) is only available to single-classed fighters, but weapon expertise can be learned by paladins, rangers, and multi-classed fighters. There's no reason a single-classed fighter *couldn't* learn expertise instead of specialization, but expertise is just as expensive as specialization and isn't as good.

Weapon expertise allows a character to gain extra attacks as if he or she were a weapon specialist. At 1st level, an expert with the long sword gets to attack three times per two rounds. Weapon expertise also allows the use of any unusual weapon properties reserved for specialist use. Weapon expertise does *not* grant the character extra attack or damage bonuses, as weapon specialization does.

Note that *Skills & Powers* allows a character to "customize" his class and receive abilities he normally could not attain. Under these rules, paladins, rangers, and multi-classed fighters *can* specialize at the cost of sacrificing other abilities or advantages. Similarly, priests and rogues may be able to gain weapon expertise. If you aren't using the *Skills & Powers* book, we recommend that you limit specialization and mastery to single-class fighters only, and limit expertise to paladins, rangers, and multi-class fighters.

Specialization

By spending an extra proficiency slot on a weapon, a single-class fighter character can become a *specialist*. A fighter may only specialize in one weapon at a time. If she wishes to change her specialization to a different weapon, she must spend *two* extra proficiency slots to become a specialist in the new weapon, and loses all

benefits of specializing in the previous one (although she is still proficient with it and always will be). Any more changes cost three slots each, so it's a good idea to pick one weapon and stick with it.

The exact benefits of weapon specialization vary with the particular weapon involved. Generally, the types of benefits fall into one of five categories: melee weapons, missile weapons, bows, crossbows, and firearms.

Melee Weapons

Specializing in a melee weapon provides a character with two main benefits: first of all, he gains a +1 bonus to attack rolls and a +2 bonus to damage rolls with that weapon; secondly, he gains an extra attack once per two rounds. A 1st-level fighter normally attacks once per round, but a 1st-level long sword specialist attacks three times per two rounds.

Missile Weapons

This category includes slings and thrown weapons. Generally, specialists gain an increased rate of fire with these weapons and a +1 bonus to attack rolls. If a character specializes in a weapon that can be used either for melee or as a missile weapon (spears, daggers, hand axes, etc.), he gains the melee benefit described above when using the weapon for hand-to-hand combat and the increased rate of fire for using the weapon for ranged attacks.

Refer to the table below for the exact number of attacks available to the specialist for the various types of missile weapons.

Bows

Characters who specialize in the bow gain a +1 bonus to hit at any range (normal range penalties still apply, of course), an increased rate of fire, and a new range category: point-blank. Point-blank is any shot of 30 feet or less. At point-blank range, the character gains a +2 to damage. In addition, bow specialists can automatically fire first as a very fast action if they have their target covered. This supercedes the specialization rules found in the *Player's Handbook*.

Crossbows

Specialists with crossbows gain a +1 bonus to hit at any range, an increased rate of fire, and a point-blank range category, just like archers. For crossbows, point-blank range extends out to 60 feet. Crossbow specialists have a +2 bonus to damage rolls against any target at point-blank range. In addition, they share the archer's quick-shot benefit when covering an enemy.

Weapon Specialization & Mastery



Firearms

Firearms specialists are often referred to as *marksmen* or *sharpshooters*. Specializing in a firearm provides a character with three benefits: first of all, he has a better rate of fire than a nonspecialist; second, he gains a +1 bonus to hit at any range; and last, there is a 50% chance that any misfire he rolls while attacking with the firearm is simply a miss instead.

Specialist Attacks per Round

Weapon	Level of Specialist		
	1–6	7–12	13+
Melee Weapons	3/2	2/1	5/2
Blowgun	2/1	5/2	3/1
Bolas	1/1	3/2	2/1
Bows	2/1	3/1	4/1
Hand Crossbow	1/1	3/2	2/1
Light Crossbow	1/1	3/2	2/1
Heavy Crossbow	1/2	1/1	3/2
Stonebow	1/1	3/2	2/1
Repeating Crossbow	2/1	5/2	3/1
Thrown Dagger/Knife	3/1	4/1	5/1
Thrown Dart	4/1	5/1	6/1
Firearms			
Arquebus	1/3	1/2	1/1
Matchlocks	1/2	1/1	3/2
Snaplocks	1/1	3/2	2/1
Wheellock Belt Pistol	1/1	3/2	2/1
Wheellock Horse Pistol	1/2	1/1	3/2
Javelin	3/2	2/1	5/2
Sling	3/2	2/1	5/2
Staff Sling	1/1	3/2	2/1
Shuriken	3/1	4/1	5/1
Other Thrown Weapons	1/1	3/2	2/1

Weapon Mastery

There are swordsmen, and then there are *swordsmen*. A warrior who devotes his life to the study of martial combat and the characteristics of a single type of weapon can become a weapon master—a fighter whose precision, quickness, and skill are virtually unequaled anywhere.

Weapon masters are rare characters. Only single-classed fighters can ever achieve weapon mastery, and even then they do so with time, study, and sacrifice. To achieve mastery in a weapon, a character must first specialize in the use of that weapon. Then, at any time after he reaches 5th level, he can spend another profi-

ciency slot to become a weapon master. He can continue to devote proficiency slots to the study of his chosen weapon, but can't progress faster than the rate at which he gains new weapon proficiency slots. So, a character who becomes a master at 5th level couldn't acquire his second slot of mastery until 6th level, his third until 9th level, and so on.

Generally, only weapons that require some skill to handle or that have a history of cultural identification are chosen by weapon masters. Swords of any kind are the most common weapons mastered, followed by bows and then axes or spears. Polearms, crossbows, and firearms are the subject of weapon mastery only in rare cases. The DM can decide that a weapon isn't appropriate for mastery at his discretion, but he should do so before a character chooses to specialize in it.

Effects of Mastery

If a fighter spends another proficiency slot on a melee weapon he already specializes in, his attack and damage bonuses increase to +3 and +3, respectively. For bows and crossbows, his point-blank bonuses increase to +3/+3 as with melee weapons, and he gains an additional +1 to hit at all other range categories, for a total of +2. (Remember, this bonus doesn't take range modifiers into account, so the archer has a total of +2 at short, +0 at medium, and –3 at long range, if the penalties are factored in.)

A marksman who chooses to master a firearm gains an additional +1 bonus to hit, cumulative with the effects of specialization for a total bonus of +2 to hit. As with bows and crossbows, this is still reduced by range penalties. In addition, the marksman ignores heavy armor at all ranges as if he were firing at a short-range target. See Firearms in Chapter Seven for more information.

High Mastery

By spending a second slot on mastery, a character can become a *high master*. By this time, the character has spent four slots on a single weapon and is at least 6th level. High masters increase the speed factor of their chosen weapon by one category; for example, a slow weapon in the hands of a high master is automatically considered to be of average speed. High masters also score critical hits on rolls of 16 or higher rather than 18 (if the optional critical hit system is used) that hit their opponent by a margin of 5 or more.

High masters who specialize in bows, crossbows, slings, or firearms gain a new range category: extreme

Chapter Four



range. For all weapons, extreme range is $\frac{1}{2}$ farther than long range. For example, if a weapon has a normal maximum range of 18 squares, in the hands of a master it can shoot 24 ($\frac{1}{2} \times 18 = 6$, $18 + 6 = 24$) squares. Extreme range shots have a -10 penalty to hit before adjustments are made for the effects of mastery.

Grand Mastery

High masters who spend one more slot on learning their weapon of choice can become *grand masters*. Grand masters are capable of feats of swordplay that border on the fantastic. Grand masters gain one additional attack per round above and beyond a specialist's rate of attacks for their level, so a 12th-level melee weapon grand master would attack 3 times per round with his weapon of choice.

Grand masters also increase the amount of damage and the chance of a knockdown when they employ their chosen weapon. The weapon's base damage die and knockdown die are increased to the next greater die size against all opponents. A long sword thus inflicts 1d10/1d20 points of damage in the hands of a grand master, and its knockdown die is increased to a d10. If the weapon causes multiple dice of damage, all of them are increased. Thus, a two-handed sword in the hands of a grand master inflicts 3d8 points of damage on large targets. Needless to say, grand masters are extremely dangerous opponents.

Special DM Note

Weapon mastery is hard to come by, and even harder to perfect. It's not too rare for a character to become a master, but the quest to become a high master or grand master could take years. Unlike the previous levels of specialization, which can simply be selected as an advancement choice, high mastery and grand mastery should require a great deal of time and personal sacrifice on the part of the character. It's not unreasonable to require the candidate to locate someone who can teach her and spend several months of campaign time in training—possibly "sitting out" an adventure or two while she hones her skills.

While the higher levels of weapon mastery are a great goal for a character to set her eyes on, they can unbalance a game very quickly. Exercise tight control over the acquisition of weapon mastery in your campaign, and make certain that the players realize just how rare and special their weapon master characters really are.

Fighting Style Specializations

Knowing how to use a particular fighting style is almost as important as being proficient with a weapon. The various fighting styles are introduced in Chapter Two; warriors automatically know every style, while the other character types are limited in their knowledge of fighting styles. If a nonwarrior wishes to learn a style he doesn't know, he can do so at the cost of a weapon proficiency.

In addition to simply knowing a style, warriors, priests, and rogues can specialize in that method of fighting by spending a weapon proficiency slot. The exact effects of style specialization vary from style to style. Note that warriors can specialize in a weapon, and then specialize in an appropriate style. In fact, warriors can specialize in as many styles as they like, as long as they have the proficiency slots (or character points) available. Priests and rogues can only specialize in one style.

Weapon and Shield Style

Normally, a character employing a shield in his off hand can shield-rush, shield-punch, block, or trap as if it were a secondary weapon, with the normal penalties for attacking with two weapons. The disadvantage is that the shield's AC bonus is forfeited for any round in which it is used this way.

However, characters who specialize in weapon and shield style can choose to make one of these secondary attacks every round without losing the AC benefit for carrying a shield. If the heroic fray rules from Chapter Two are in use, the character only gets one secondary attack, not two, but his primary weapon attacks are still doubled, of course.

One-handed Weapon Style

The character is always free to treat his empty hand as a "secondary weapon" and punch, grab, or otherwise annoy anyone he is fighting. The normal penalties for using two weapons apply. If the character is also familiar with the two-handed weapon style and his weapon can be used either one- or two-handed, he can switch back and forth between the two styles at the beginning of every round of combat.

Characters who specialize in this style gain a special AC bonus of +1 while fighting with a one-handed weapon and no shield or off-hand weapon. By spend-

Weapon Specialization & Mastery

ing an additional proficiency slot, the character can increase his AC bonus to +2, but that's the maximum benefit for style specialization.

Two-handed Weapon Style

Many weapons are so large that a character is required to use both hands to wield them. The rule of thumb is simple: a character can use a weapon with a size equal to or less than her own in one hand and can use a weapon one size larger than herself if she wields it two-handed.

If a character specializes in two-handed weapon style, she increases the speed of her weapon by one category (slow to average, average to fast) when she fights using a two-handed weapon. If you're not using the new initiative rules presented in Chapter One, the weapon's speed factor drops by 3.

There are a few weapons that can normally be employed one-handed or two-handed; these are noted in the weapons list of Chapter Seven. There are also a variety of weapons that are normally used one-handed but that *can* be used two-handed. This would allow a specialist in this style to gain the speed benefit mentioned above. In addition, the two-handed style specialist gains a +1 to damage rolls when using a one-handed weapon in two hands.

Two-Weapon Style

This is a difficult style to master, since it requires exceptional coordination and skill. Normally, characters who fight with a weapon in each hand suffer a -2 penalty to attacks with their primary hand and a -4 penalty to attacks with the off-hand weapon. This can be partially or completely negated by the character's reaction adjustment for Dexterity (or Dex/Aim if you're also using *Skills & Powers*). Characters who specialize in this style reduce their penalty to 0 and -2, respectively. Ambidextrous

characters who specialize in this style suffer no penalty with either attack.

The character's secondary weapon *must* be one size smaller than his primary weapon—but knives and daggers can always be used as secondary weapons, regardless of the size of the primary weapon. Note that this means that for Man-sized characters, the secondary weapon has to be size S. However, if a character spends a second proficiency slot on two-weapon style specialization, he gains the ability to use two weapons of equal size, as long as he can use each one as a one-handed weapon. Rangers are considered to have the first slot of this style specialization for free as a character ability.

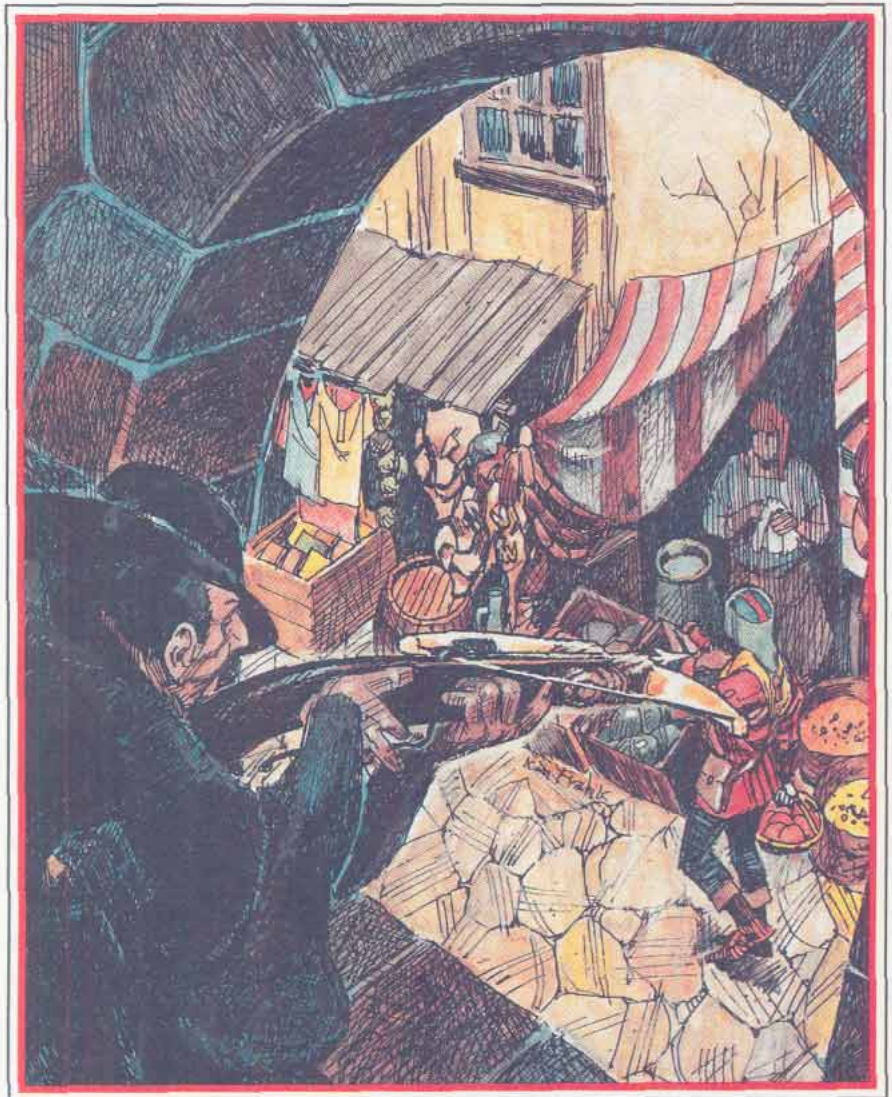

Chapter Four



Missile or Thrown Weapon Style

Some heroes specialize in fighting with ranged weapons; Robin Hood and William Tell spring to mind as good examples. Characters who choose to specialize in missile or thrown weapon style gain two benefits. First, they can move up to half their normal movement rate and still attack with their full rate of fire, or make a full move and attack at half their rate of fire. Second, they gain a bonus of -1 to their AC against enemy missile fire while attacking with a ranged weapon.

Horse Archers

A proficient archer and rider who specializes in missile style gains a special benefit when mounted: any penalties he suffers for shooting while riding are reduced by 2. Normally, a character suffers a -2 penalty to missile attacks if his mount is moving at up to half its normal speed, and a -4 penalty if his mount is moving at full speed. Horse archers suffer no penalty for half-speed firing, and only a -2 penalty for firing at full speed.

Horse archers are rare in a typical Western European fantasy setting. Historically, most horse archers came from central Asia. At the DM's discretion, a character may not qualify for this special benefit unless he has a suitable origin or makes an effort to locate someone from that culture who can teach him.

Local Fighting Styles

Many specialized forms of combat evolved throughout the world in various locations. Some Roman gladiators were trained to fight with net and trident; Western Europe developed the joust; and martial arts evolved throughout southern and eastern Asia. If a character comes from an area where a unique form of combat has evolved, she may spend a weapon proficiency slot to specialize in that form of fighting.

Some examples of specialized fighting styles include: rapier and main-gauche, sabre, fighting sticks or nunchuks, katana and wakizashi, and so on. If a character spends a proficiency slot to specialize in one of these local styles, she can choose one of the following benefits:

- A -1 bonus to Armor Class;
- A $+1$ bonus to attack rolls;
- The ability to make a free block or trap maneuver without spending an attack to do so;

- The negation of penalties for fighting with two weapons;
- A free unarmed punch or kick.

For example, specialization in fighting with matched sticks or nunchuks may confer the negation of the normal $-2/-4$ attack penalty for fighting with two weapons. Rapier and main-gauche specialization may provide the character with an extra block or trap maneuver with his main-gauche. The DM is the final judge of what bonus a particular style provides and whether or not a character can specialize in it.

Special Talents

Weapon proficiencies can also be used to acquire a variety of special perks, traits, and characteristics useful for a fighter. Some of these talents were originally presented as nonweapon proficiencies and are noted with an asterisk; they can be purchased with either type of proficiency slot.

As always, the DM is the final arbiter of whether or not a particular option or ability is permitted in his campaign. If he decides that an ability doesn't fit, he can require the players to choose another talent.

Alertness* (1 slot/6 CP) Wisdom/Intuition, $+1$
Groups: All

Some characters are unnaturally alert and instinctively note signs of trouble that other characters may miss. A character with this proficiency reduces his chance of being surprised by 1 in 10 if he makes a successful proficiency check. In situations where surprise is automatic, the character may still attempt a proficiency check. If he passes, he is surprised at the normal chance instead of automatically.

Ambidexterity (1 slot/4 CP) Dexterity/Aim
Groups: Warrior, Rogue

Ambidextrous characters are able to use either hand with equal coordination and skill. They are neither right-handed nor left-handed. When fighting in two-weapon style, an ambidextrous character has two "primary" hands, and suffers a -2 penalty to hit with either weapon. If the ambidextrous character spends a slot to specialize in two-weapon fighting style, he suffers no penalty to attacks with either weapon.

Ambush (1 slot/4 CP) Intelligence/Reason
Groups: Warrior, Rogue Initial rating: 5

Weapon Specialization & Mastery



A character with this proficiency is skilled at laying ambushes and setting up surprise attacks. Most characters can set up an adequate ambush when the terrain favors it and they know the enemy is coming, but a character who spends a slot on this skill is able to create ambushes where ambushes wouldn't normally be possible.

Ambushes are impossible if the attackers have already been spotted by the victims; there's no point in hiding then. If the ambushing party knows their quarry is coming to them, they can lay an ambush. If the attack is going to take place in difficult or unusual circumstances, a proficiency check may be called for; failure indicates that the victims have spotted the ambush before they walk into it. Otherwise, the ambush is guaranteed to achieve surprise.

Camouflage (1 slot/4 CP) Intelligence/Knowledge
Groups: Warrior, Rogue Initial rating: 5

Characters skilled in camouflage understand how to stay out of sight in natural surroundings. Unlike hiding in shadows, camouflage requires one of two things: good cover nearby or a lot of preparation. It's possible for a character to hide himself on a flat, rocky desert, but he'd need to have special clothes and time to ready a hiding spot. On the other hand, almost anyone can duck behind a tree on short notice.

If the character passes his camouflage check, he is considered to be effectively *invisible* as long as he doesn't move. He can avoid encounters if he chooses, or gain a -1 bonus on his chance to surprise someone who doesn't spot him. The character's check is modified as noted below:

- **Ground Cover:** -4 penalty if no vegetation is nearby;
- **Terrain:** +1 bonus if terrain is rocky, hilly, or broken, +2 if very rocky;
- **Preparation Time:** -2 if character has only one round of warning, -4 if character has no warning.

Rangers and thieves gain a +40% to their chance to hide in shadows if they pass a camouflage check in conjunction with their attempt to hide in shadows.

Dirty Fighting (1 slot/3 CP) Intelligence/Knowledge
Group: Warriors, Rogues Initial rating: 5

Veteran brawlers and soldiers acquire a repertoire of feints, ruses, and various unsportsmanlike tactics that can come in handy in a fight. A character with this "skill" can attempt to use a dirty trick once per fight; if he succeeds, he gains a +1 bonus to his next attack roll. If

there's some reason the enemy believes the character will fight honorably (hardly a wise assumption!) the bonus is +2.

Once a particular enemy has fallen prey to the character's dirty trick, he can never be caught off-guard again. In addition, if the character's opponent is skilled in dirty fighting himself, the attempt automatically fails.

Endurance* (2 slots/4 CP) Con/Fitness
Group: Warrior Initial rating: 3

This proficiency allows a character to perform strenuous physical activity twice as long as a normal character before fatigue and exhaustion set in. If the fatigue rules from Chapter One are in play, a character with this proficiency increases his fatigue points by 50%.

Fine Balance (2 slots/5 CP) Dex/Balance
Group: Warrior, Rogue Initial rating: 7

Characters with this talent are blessed with an innate sense of balance and have an uncanny knack for keeping their feet under them. With a successful proficiency check, the character gains a +2 bonus on any climbing checks, saving throws, or ability checks to avoid slipping or falling. In addition, the character reduces any penalties for fighting in off-balance or awkward situations by 2 points.

The fine balance talent is also very useful for tightrope walking, tumbling, and climbing walls. If the DM determines that a particular feat would be influenced by the character's exceptional balance, the character gains a +2 (on d20 rolls) or +10% (on d100 rolls) bonus to his rolls to resolve the action.

Iron Will (2 slots/6 CP) Wisdom/Willpower, -2
Group: Warrior, Priest Initial rating: 3

Some people are possessed of an amazing ability to drive themselves on despite injuries or exhaustion that would stop another person in his tracks. A character with the iron will talent gains a +1 bonus to saving throws vs. mind-affecting spells or effects, including *charms*, *holds*, *hypnotism*, *fascination*, *suggestion*, and other such spells.

In addition, characters with iron will have the unique ability to keep fighting even after being reduced to negative hit points. Each round that the character wishes to remain conscious, he must roll a successful saving throw vs. death with his negative hit point total as a modifier to the roll. For example, a character reduced to -5 hit points can try to stay on his feet and keep moving and fighting by succeeding on a saving throw roll

Chapter Four

with a -5 penalty. As long as the character remains conscious, his condition does not worsen—in other words, he doesn't begin to lose 1 additional hit point per round until he actually passes out.

Leadership (1 slot/3 CP) Charisma/Leadership, -1
Group: Warrior Initial rating: 5

Characters with the leadership talent understand how to motivate troops and get the most out of their men. In battlefield situations, a military unit led by the hero gains a +2 bonus to any morale checks they have to make. If you are playing with the mass combat rules in Chapter Eight, the character is treated as if he were three levels higher than he really is, so a 4th-level fighter can command troops as a 7th-level fighter if he possesses this talent.

Quickness (2 slots/6 CP)

Group: Warrior, Rogue

Dexterity/Aim

Initial rating: 3

A character with this talent is unusually fast. Her hand-eye coordination is excellent, and she can often get past her opponent's defenses before they realize how quick she really is. In combat, she gains a special -2 bonus to her initiative roll if she makes a proficiency check. She can use this bonus if she moves or makes an attack with a weapon of average speed or quicker, but her special bonus does not apply to attacks with slow weapons or stationary actions such as guarding or parrying.

Steady Hand (1 slot/5 CP)

Group: Warrior, Rogue

Dexterity/Aim

Characters with this talent are excellent shots with bows or crossbows. They have an unusually good eye for distance, a knack for judging a tricky shot, and a smooth and easy aim and release. If the character takes a full round to aim his shot (i.e., voluntarily holds his action until last in the round) he suffers no penalty for a medium-range shot and only a -2 penalty for a long-range shot. If the character would normally receive multiple attacks with his weapon, he has to forfeit them in order to use this talent—he can make only one shot per round.

Trouble Sense (1 slot/4 CP) Wis./Int.

Group: General

Initial rating: 3

Sometimes known as a danger sense, this talent gives the character a chance to detect otherwise undetectable threats by instinct. The character's trouble sense comes into play when the character is threatened by a danger he hasn't noticed yet.

The DM should make trouble sense checks in secret. If the character succeeds, he is only surprised on a roll of 1 by a sneak attack and treats any rear attacks as flank attacks instead. The DM can modify the proficiency check if the character is taking extra precautions or if the attacker would be particularly hard to notice before striking.



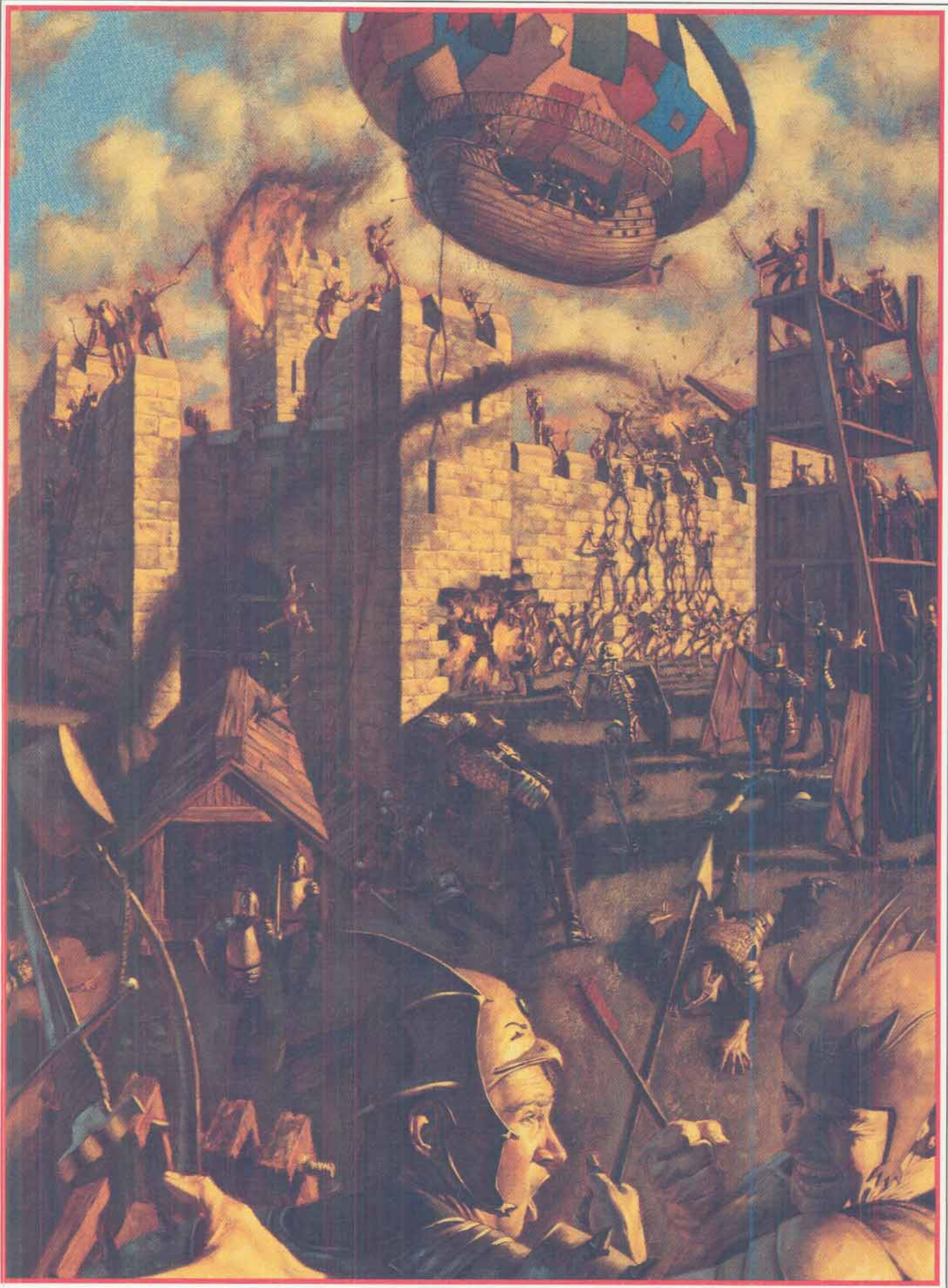

Chapter Five: Unarmed Combat



Characters all too frequently find themselves weaponless while embroiled in a fight. Experienced players often prefer to have their characters voluntarily lay aside their weapons to engage in nonlethal combat, especially when attempting to capture an opponent who is more valuable to them alive than dead.

There are three parts to this chapter. The first is *Brawling*; it covers *pummeling*, *wrestling*, and *overbearing*, the three basic types of unarmed combat (though improvised weapons can be used in pummeling). *Subduing* is a type of armed combat that employs weapons in nonlethal ways. *Martial Arts* is a set of skills that can make an unarmed character as formidable and unpredictable as a swordsman.

Does This Belong in My Campaign?

The material in this chapter is an extension of the combat options in Chapter Two, and it is intended for use with the **PLAYER'S OPTION** combat system presented in Chapter One. This chapter can be used by itself, however.

Brawling, subduing, and martial arts can all be incorporated into a campaign separately or together.

Unarmed Combat



Brawling No character is entirely helpless while still conscious and free to move. Improvised weapons such as iron spikes and chairs often lie within easy reach, and a blow from a fist often can be as telling as a dagger thrust.

Brawling is generally less deadly to the defender than armed combat, but it does, however, carry its own risks.

Brawling Attacks Against Armed Opponents

Any brawling attack provokes an attack of opportunity from any and all opponents who are armed and threatening the assailant. The defender gets a +4 bonus to attack and damage rolls. If an attack of opportunity slays the attacker, there is no brawling attack. If an attack of opportunity creates a knockdown chance, the brawling attack automatically fails and is wasted, even if the attacker's saving throw succeeds and he is not knocked down—the defender's weapon keeps the attacker at bay. If an attack of opportunity results in a critical hit, the character who scored the hit can choose to roll for the critical hit (see Chapter Six) or force the brawling attack to automatically fail.

Temporary Damage

Only one quarter of any damage inflicted in brawling combat is normal. Divide the damage from each attack by four and round down. The result is the normal damage from the attack; all remaining damage is temporary. If a single attack inflicts less than four points of damage it is all temporary damage. (Two humans with average Strength scores pummeling each other with bare knuckles can inflict only temporary damage.)

Temporary damage automatically heals at the rate of one point per combat round (or standard round if the **PLAYER'S OPTION** combat system is not in use) no matter what the injured character does. It is helpful to keep track of temporary damage separately.

Characters reduced to -10 hit points by temporary damage (or a combination of temporary and normal damage) are still dead. Characters reduced to between 0 to -9 hit points recover one temporary damage point each combat round (instead of losing a point each round), but remain unconscious for 2d6 full turns or until healed. Normal damage takes precedence over temporary damage. If a character has suffered enough normal damage to reduce his hit points below zero, he

loses one hit point each round (as described in Chapter One under **Damage and Dying**) and regains no temporary damage.

The attacker in an unarmed combat can opt not to inflict damage—this is called pulling the punch, though it applies to all forms of unarmed combat. The attack may still generate special effects such as knockouts, knockdowns, holds, locks, and pins, but it inflicts no damage at all.

Opposed Rolls

The brawling procedures make extensive use of opposed rolls. See Chapter Two for a discussion of how to use opposed rolls in combat. Note that in an opposed ability check a die roll of 20 is always a failure, even if the effective score is 20 or more. In an opposed attack roll, a die roll of 1 is always a failure, even if adjustments to the roll would allow for success.

Pummeling Pummeling includes most attacks made with hands, fists, elbows, and the like. Humanoid and partially humanoid creatures with racial intelligence of at least low can make pummeling attacks. Nonhumanoid creatures with racial intelligence of at least average and with manipulative appendages at least as large and strong as human hands and arms also can pummel. Humans, demihumans, orcs, ogres, giants, centaurs, and similar creatures can make pummeling attacks. Great cats, octopi, oozes, horses, and other creatures who lack intelligence or prehensile appendages cannot. Common sense must apply. For example, the DM might allow androsphinxes to make pummeling attacks if they retract their claws. Generally, however, creatures with natural attacks use them in preference to pummeling attacks.

Pummeling requires at least one free hand, although the attacker may wear a metal gauntlet or similar item. A character may also use a weapon pommel or an improvised weapon, such as a mug or bottle, in a pummeling attack. Attacks with improvised weapons provoke attacks of opportunity just as other brawling attacks do.

The target of a pummeling attack must be alive, non-vegetable, organic, and non-fluid. Undead, shambling mounds, golems, and jellies are among the many creatures that cannot be pummeled.

Pummeling is ineffective against creatures who can be harmed only by special or magical weapons unless the attacker functions as a magical weapon powerful

Chapter Five



enough to hurt the creature (see *DMG*, Table 46; note that character levels never apply to the table). Elementals, fiends, and most extraplanar creatures are immune to pummeling unless attacked by similar creatures or by characters using magical weapons.

Creatures immune to blunt (type B) weapons are immune to pummeling attacks.

No creature can pummel an opponent more than one size larger than itself unless the target is not standing up (prone, kneeling, or sitting) or the attacker has a height advantage or can fly. For example, a halfling usually cannot pummel a hill giant.

Pummeling Procedures

Most characters can make a single pummeling attack each round. Any character can gain an extra pummeling attack each round by punching with both hands (provided both hands are free). However, the character suffers the penalties for attacking with two weapons (see Chapter Two).

To make a pummeling attack, the character makes an attack roll vs. the defender's Armor Class. Pummeling damage and speed varies with the type of implement used to pummel:

- Small, soft objects (bare hands) inflict 1d2 points of damage; base speed is fast.
- Small, hard objects (mailed fists, mugs, weapon pommels) inflict 1d3 points of damage; base speed is fast.
- Large, soft objects (saddles, unconscious characters) inflict 1d4 points of damage; base speed is slow.
- Large, hard objects (chairs, small tables, sacks of coins) inflict 1d6 points of damage; base speed is slow.

To be used as an improvised weapon, an object must weigh no more than one third of the attacker's maximum press score (from *PHB*, Table 1) and its greatest dimension can be no larger than half the attacker's height. For example, a Man-sized creature could wield a tall stool in a pummeling attack, but not a stepladder or banquet table; common sense must apply.

A cestus (see Chapter Seven) is a special case. A character employing a cestus uses the pummeling procedure but inflicts normal damage.

Strength bonuses to attack and damage rolls apply to all pummeling attacks.

There is no knockdown die for pummeling attacks.

Instead, there is an opposed Strength roll to see if the defender is knocked down. Modify the opposing Strength scores as follows:

- 2-point bonus or penalty per size difference of the attacker versus the defender;
- +1 for attacking with a large object;
- +1, +2, or +3 for a specialized, master, or grand master attacker.

The defender is knocked down if the attacker wins the opposed Strength roll. If both Strength rolls succeed, the character who succeeds with the highest roll is the winner. If the attacker fails her Strength roll, there is no knockdown no matter what the defender rolls. If the defender fails her Strength roll, there is no knockdown unless the attacker's roll succeeds.

If a pummeling attack scores a critical hit, do not use the procedures in Chapter Six. Instead, the defender must save vs. death or be knocked unconscious for 3d10 combat rounds. The attacker's hit probability adjustment (from Table 1 in the *PHB*) for Strength applies as a bonus or penalty to the saving throw. If the attacker does not have a Strength score, determine the attacker's effective Strength using the formula found in Chapter Two and apply the appropriate modifier from the *PHB*.

Pummeling Skill Levels

- **Nonproficient:** Most characters have had some experience with pummeling since early childhood, and nonproficient characters are very rare. If the optional character point system from the *Skills & Powers* book is in use, a character who is nonproficient in pummeling may claim 3 extra character points. Such characters are very rare, however, and the DM and the player should agree on a reason why the character is nonproficient; perhaps the character had an isolated and nonviolent childhood, or comes from a culture where fistfighting is unknown. A nonproficient pummeler suffers the attack penalty listed for his class in Table 34 from the *PHB* and cannot score a knockdown or knockout with a pummeling attack.
- **Familiar:** The vast majority of characters are assumed to be familiar with pummeling, and need not spend any character points or proficiency slots on the skill. Such characters can make one pummeling attack each combat round with no penalty.
- **Proficient:** Any character can spend character points (or a weapon proficiency) to become proficient at

Unarmed Combat



pummeling. Nonwarriors gain no benefit from pummeling proficiency. Proficient warriors gain their full allotment of melee attacks when pummeling.

- **Expert:** Any character can spend character points (or weapon proficiencies) to become expert at pummeling. Expert warriors who are entitled to more than one melee attack each round can make the same number of pummeling attacks each round, but gain no other benefits. Expert nonwarriors can make multiple pummeling attacks at the same rate as a nonspecialized warrior of the same level.
- **Specialized:** Generally, only single-classed fighters can become pummeling specialists, though there are optional rules in the *Skills & Powers* book that allow other characters to specialize. Pummeling specialists gain the normal specialist attack and damage bonuses and extra attacks. Specialists' attack bonuses apply to their Strength scores when rolling for knockdowns.
- **Master:** Only single-classed warriors can attain mastery in pummeling. Pummeling masters gain the normal master attack and damage bonuses and extra attacks. Masters' attack bonuses apply to their Strength scores when rolling for knockdowns, and apply as penalties to saving throws vs. knockouts. Grand master pummelers can use critical augmentation to score knockouts on attack rolls of 16 or better.

An Example of Pummeling

Anada, an 8th-level elf warrior, has just escaped from a cell inside a bugbear lair. He has no weapons but still wears his suit of *chain mail +1*. Anada surprises a pair of unwary bugbear guards and moves in to attack them from behind. The bugbears are Large creatures, but Anada is Man-sized, so his pummeling attacks can effect them. Anada is familiar with pummeling, and can make only one pummeling attack each round despite his warrior level (though he could make a second

attack with his other fist and suffer the penalties for a two-handed attack).

Because he is not in a threatened square, his first punch does not provoke an attack of opportunity. Anada's attack roll must be good enough to hit AC 5, a bugbear's normal Armor Class. He hits with a roll of 18, good enough to score a critical hit. Anada's Strength is 17, so the bugbear suffers $2d2+1$ points of damage from Anada's bare fists (the damage is doubled due to the critical hit). The blow inflicts 3 points of damage, all temporary. Next, Anada and the bugbear must make opposed Strength rolls. Anada receives a -2 penalty to his Strength score because he is one size class smaller than his opponent. The bugbear's effective Strength is 17, with a $+2$ bonus because it is larger than Anada. Anada rolls another 18 and the bugbear rolls a 10. The



Chapter Five



bugbear is not knocked down. (Because Anada failed his Strength roll, the bugbear would not be knocked down in any case.)

The critical hit makes the bugbear roll a saving throw vs. death at -1 (because of Anada's 17 Strength) to avoid being knocked out. It fails the roll and falls unconscious for 3d10 combat turns. The second bugbear takes no action, because Anada has surprise.

The next round, Anada wins initiative and moves in to pummel the second bugbear, who turns to face him. Anada's punch provokes an attack of opportunity, because the bugbear threatens him. The bugbear has +4 attack and damage bonuses and its racial damage bonus of +2. It hits Anada for 9 points of normal damage and scores a knockdown chance. Anada's pummeling attack automatically fails, but his saving throw is successful and he is not knocked down. The bugbear decides to use its regular attack to punch Anada with its free hand, in hopes of recapturing him alive. It must hit AC 3 (Anada has a 15 Dexterity in addition to his magical armor) and misses.

During the next round Anada tries to pick up the fallen bugbear's weapon. The second bugbear wins initiative, however, and tries to punch Anada again. Anada is not yet armed, so there is no attack of opportunity. This time the bugbear hits, inflicting 1d3+2 points of damage with its mailed fist. It scores 5 points of damage, 1 normal and 4 temporary. Anada has now suffered 14 points of damage, 10 normal and 4 temporary. Unfortunately, Anada only had 12 hit points at the start of this battle, having been wounded earlier. Because his current hit point total is -2 , he falls unconscious for 2d6 full turns. The bugbears drag him back to his cell, and watch him more carefully this time.

Special Pummeling Maneuvers

The following are special attacks that can be attempted as a pummeling attack. They are typically attempted to cause a special situation, such as a knockout.

Sapping

The basic rules for sapping are found in Chapter Two. However, a character may attempt to make a ranged sap attempt with a thrown object, subject to range, Strength, and Dexterity modifiers. Damage is determined by the object's size and hardness, as given above. There is a one-phase delay when making a ranged pummeling attack; small objects become average, large objects become very slow. Small objects

have a maximum range of 15 yards. Short range is 5 yards or less, medium range is 5–10 yards, and long range is 10–15 yards. Large objects cannot be thrown unless they can be wielded as improvised weapons as described above; they have a maximum range of 5 yards and are always considered to be at medium range. Size Large and larger creatures might be able to hurl some large objects, such as sacks of coins, as though they were small objects.

Kicking

Characters attacking with a height advantage (or attacking a prone, kneeling, or sitting opponent) can pummel by kicking instead of punching. Humanoid characters tend to have stronger legs than arms, and inflict extra damage:

- **Bare feet:** 1d3 points of damage;
- **Shoes, boots:** 1d4 points of damage;
- **Heavy boots:** 1d6 points of damage;
- **Iron-shod or hobnailed boots:** 1d8 points of damage.

Wrestling Wrestling includes all attacks aimed at grasping and holding an opponent. Any creature with racial intelligence of at least semi- can make wrestling attacks if it also has grasping appendages that it could use to restrain an opponent. Incorporeal and amorphous creatures cannot make wrestling attacks and cannot be wrestled. Limbless creatures, such as worms, snakes, and the like, generally cannot wrestle, though constrictor snakes can be assumed to be using a form of wrestling.

Wormlike and snakelike creatures are resistant to wrestling damage, but can be held or locked so they cannot attack until they win free of the hold. Creatures immune to normal weapons have a natural resistance to wrestling attacks, so they can be grappled or pinned but take no damage from a hold unless the attacker functions as a magical weapon. Immunity to normal weapons, however, does not protect a creature from the effects of a lock, including damage.

Wrestling requires both hands free. Shields, which are normally worn strapped to the forearm, interfere with the character's grip and prevent wrestling.

Wrestling combat always takes place between two opponents; multiple attackers cannot make a wrestling attack as a group. Damage from wrestling holds and locks is mostly temporary, just like other types of brawling damage.

Unarmed Combat



Wrestling Procedures

Most characters can make one wrestling attack each round. Wrestling attacks take place on the attacker's base initiative phase.

A wrestler makes an attack roll vs. Armor Class 10, regardless of the defender's actual Armor Class. Bonuses for the defender's Dexterity and magical protections apply. Effects that provide a flat Armor Class, such as magical bracers or *shield* spells, count as a +1 bonus regardless of how strong their enchantments are. If the attacker misses, his action phase ends. If the attacker scores a critical hit, the defender is automatically held. The attacker enters the defender's square and inflicts 1d2 points of damage. The attacker can immediately try for a lock (see *Previously Established Holds*, below). If there is no critical hit, the attacker enters the defender's square and immediately checks for a hold.

Holds

To check for a hold, the combatants make an opposed attack roll vs. AC 10 (Dexterity and magical bonuses apply). Strength bonuses apply, along with the following modifiers:

- 4-point bonus or penalty per size difference of the attacker versus the defender;
- -1 for a defender normally immune to the attack;
- -2 for defenders with unusually supple bodies (snakes, eels, worms, etc.).

The attacker must win the opposed roll to achieve a hold. If the defender wins, if there is a tie, or if both rolls fail, the attacker is driven back to his original square and the grapple is broken. Both characters retain their original facings.

If the attacker wins the opposed roll, the attacker achieves a hold. The defender suffers 1d2 points of damage unless immune to the attack, and the attacker can try for a lock during his next attack. A hold lasts until the attacker frees the defender, or the defender breaks free. Grappled characters cannot move until they free themselves, and they cannot make attacks of opportunity. Checking for a hold ends the attacker's action phase; the character cannot attack again until he would normally be eligible for a melee attack (usually the next combat round); however, the character can counter the defender's attempts to get free (by making opposed rolls).

Strength bonuses to attack and damage rolls apply to all wrestling attacks, holds, and locks.

Previously Established Holds and Locks

When a character is eligible to make an attack and begins the action phase with a character in his grasp, the attacker can release the opponent, try to improve his grip, or just hold on.

If the attacker releases his opponent he can immediately attempt another unarmed attack, draw a weapon and attack (this counts as a half-move action), or attempt some other action normally available to the character, such as movement.

If the attacker tries to improve his grip, make another opposed attack roll as described above. If both attack rolls fail, there is no change in the combatants' status—they remain grappled and no damage is inflicted. If the defender wins, the attacker suffers 1d2 points of damage (plus Strength bonus) and the defender's position improves one place. Locked defenders become held, held defenders break free. If the defender wins with a roll good enough to score a critical hit, the defender immediately scores a lock on the attacker, and can choose a lock result from the table below. The defender now controls the wrestling sequence and is treated as the attacker in subsequent action phases. If the attacker wins the opposed roll, the defender suffers 1d2 points of damage and the attacker's position improves one place; held characters become locked.

If the attacker just tries to hold on, conduct another opposed roll. Unless the defender wins, his status does not change; held characters remain held and suffer 1d2 points of damage, and locked characters remain locked and suffer a lock result of the attacker's choice. If the defender wins, his status improves one place, as noted above. There is no chance for the defender to roll a critical hit and achieve a lock on the attacker. If both attacks fail, or if there is a tie, the defender's status remains unchanged, but the defender takes no damage and cannot suffer a lock result (though an established lock is not broken). The advantage of holding on is that there is also no chance for a critical hit to reverse the attacker's fortunes.

A character who decides to hold on after he has achieved a lock can only repeat the previous lock effect. If the character wishes to change effects, he must win another opposed roll.

Chapter Five



Breaking Free

A defender who begins an action phase in another character's grasp cannot move. The only combat actions he can take is an attack with a size S or natural weapon, pummeling, or wrestling. These attacks must be directed at the opponent grappling the character. Attacks with size S weapons and pummeling attacks suffer a -2 attack penalty. Natural and armed attacks are not possible if the character's original facing would not allow them. For example, a fighter who makes a wrestling attack from one of a lion's rear squares could not be subjected to the lion's claw attacks, though the lion could turn its head to bite.

If the defender scores a critical hit with a weapon or natural attack, he can opt to inflict double damage (and perhaps roll for a special effect according to the rules presented in Chapter Six) or force the attacker to release him. If the defender scores a knockdown with a pummeling or weapon attack, he breaks free.

If the defender makes a wrestling attack, conduct an opposed attack roll as described above. If both attacks fail, there is no change in the combatants' status—they remain grappled or locked and no damage is inflicted. If the defender wins, the attacker suffers 1d2 points of damage (plus Strength bonus) and the defender's position improves one place. Locked defenders become grappled, and grappled characters break free. If the defender wins with a roll good enough to score a critical hit, the defender immediately scores a lock on the attacker and can choose a lock result from the table below. The defender now controls the wrestling sequence and is treated as the attacker in subsequent action phases. If the attacker wins the opposed roll, there is no change in the defender's status. If the attacker wins with a roll good enough to score a critical hit, the attacker automatically achieves a lock.

Assistance

Wrestling involves seizing and controlling the defender's body; multiple attackers tend to hinder each other more than the defender. Even Very Large creatures that occupy more than one space on the map cannot be wrestled *en masse* because it is impossible to coordinate their actions as the defender thrashes about. The attacker's companions, however, can make melee, pummeling, and overbearing attacks against the defender. (A character involved in wrestling combat does not count as part of the pile if his companions try to overbear the defender).

It is equally difficult to involve multiple defenders in

wrestling combat. A single character can try to grapple the attacking wrestler and pry him loose from the defender. If the rescuer achieves a hold (or a lock) on the attacker, the original defender breaks free and the original attacker is pulled into the rescuer's square.

A hold or lock also can be broken by scoring a knockdown or critical hit with a weapon or pummeling attack, as described above, or by overbearing the attacker. Additional defenders who threaten the attacker can make attacks of opportunity every time the attacker initiates an opposed roll.

Missile attacks directed at wrestlers have a chance to hit either characters as described in Chapter One.

Locks

Characters who become locked suffer one of the following effects, chosen by the character who achieved the lock:

- **Throw:** The attacker literally throws the defender through the air. The defender lands, prone, 1 or 2 squares away in any direction the attacker chooses. The defender suffers 1d4 points of damage unless he lands on a soft, yielding surface, but is freed from the attacker's grasp. Defenders thrown onto particularly hard and unyielding surfaces, such as solid stone floors or walls, take 1d4+1 points of damage. If the defender is thrown into another creature, immediately conduct an overbearing attack against the creature struck using the attacker's Strength score and the thrown creature's size. If the defender is thrown into a hazardous area, such as a pool of burning oil or a set of sharp spikes, he takes additional damage from the hazard, just as though he has stepped or fallen into it. Hazards usually inflict normal (not temporary) damage. Defenders at least two size classes larger than their attackers cannot be thrown. Treat the throw as a takedown. If the defender is the same size or smaller than the attacker, the attacker can make a half move before throwing his opponent.
- **Takedown:** The attacker makes the defender fall to the ground in the combat square. The defender suffers 1d3 points of damage and remains in the attacker's grasp.
- **Slam:** The attacker hurls the defender violently to the ground in the combat square. The lock automatically becomes a hold and the victim breaks free if he rolls a successful saving throw vs. breath weapon. The defender suffers 1d8 points of damage in any

Unarmed Combat



case. The defender suffers 1d8+1 points of damage if slammed into solid ground, and the appropriate amount of damage is inflicted if the defender is slammed into hazardous ground. Defenders at least two size classes larger than their attackers cannot be slammed. Treat the slam as a takedown.

- **Press:** The attacker squeezes or twists some part of the victim's body, inflicting damage. The victim remains in the attacker's grasp and suffers 1d6+1 points of damage. If the attacker repeats the press on his next action phase, the damage bonus increase to +2 and continues to increase if the attacker can repeat the press without interruption. A press repeated through five consecutive attacks would inflict 1d6+5 points of damage during the fifth attack.
- **Hammer:** The attacker pummels the defender or pounds his body against something. The defender suffers 1d2 points of damage and must roll a successful saving throw vs. death or be knocked unconscious for 3d10 combat rounds. There is no adjustment to the roll as there is in a pummeling attack and no damage adjustment for items the attacker holds or wears on his hands.
- **Manipulate:** The attacker takes control over the defender's body. The attacker can pry items out of the defender's grasp, remove exposed equipment from the defender's body, bind the defender's limbs, negate one of the defender's natural attacks, or inhibit the defender's actions in other ways at the DM's discretion. The defender suffers 1d2 points of damage from the attacker's manhandling.

The attacker can remove one item or bind one limb with a manacle in one attack phase. It takes two attack phases to tie a limb with rope. If in doubt about the attacker's ability to remove an item, allow the attacker to make an open doors or bend bars roll to perform the action. For example, removing a helmet from a struggling hobgoblin would require an open doors roll. Removing a helmet from a struggling storm giant would require a bend bars roll.

It is often possible to maintain a manipulation while performing a press or takedown. If the defender wins an opposed roll while multiple locks are established, all of them are broken.

- **Carry:** The attacker lifts the defender into the air and makes a normal move. The defender's weight (and the weight of the defender's equipment) is added to the attacker's encumbrance rating. The attacker cannot choose this lock if the defender's total weight

(with equipment) equals or exceeds the attacker's maximum press values (see *PHB*, Chapter 1).

Wrestler Versus Wrestler

If two characters have declared wrestling attacks against each other, they automatically grasp each other. Skip the initial attack roll and make an opposed roll on the fastest character's action phase to see who has the advantage. The winner establishes a hold, or a lock if his roll was good enough to score a critical hit.

Wrestling Skill Levels

- **Nonproficient:** All characters have had some experience with wrestling since early childhood; the only nonproficient wrestlers are creatures that cannot make wrestling attacks at all. In most cases, creatures that cannot make wrestling attacks also cannot be wrestled. If a nonproficient creature can be wrestled, it can make opposed rolls with no penalties, but it cannot score critical hits or achieve holds or locks; the creature can merely wiggle out of the attacker's grasp (or make natural attacks). A character cannot choose to be nonproficient in wrestling and gain extra character points under the optional character point system from the *Skills & Powers* book.
- **Familiar:** Creatures that can make wrestling attacks are automatically familiar with wrestling, and need not spend any character points or proficiency slots on the skill. Such characters can make one wrestling attack each combat round with no penalty.
- **Proficient:** Any character can spend character points (or a weapon proficiency) to become proficient at wrestling. Nonwarriors gain no benefit from wrestling proficiency. Proficient warriors gain their full allotment of melee attacks when wrestling. High-level warriors can initiate multiple wrestling attacks each round and can try to improve holds or switch locks in any action phase when they are eligible to make attacks.
- **Expert:** Any character can spend character points (or weapon proficiencies) to become expert at wrestling. Expert warriors who are entitled to more than one melee attack each round can make the same number of wrestling attacks each round, but gain no other benefits. Expert nonwarriors can make multiple wrestling attacks at the same rate as a nonspecialized warrior of the same level.
- **Specialized:** Generally, only single-classed fighters can become wrestling specialists, though there are

Chapter Five



optional rules in the *Skills & Powers* book that allow other characters to specialize. Wrestling specialists gain the normal specialist attack and damage bonuses and extra attacks.

- **Master:** Only single-classed warriors can attain mastery in wrestling. Wrestling masters gain the normal master attack and damage bonuses and extra attacks. Grand master wrestlers can use critical augmentation to score quick locks on attack rolls of 16 or better.

An Example of Wrestling

Anada, the elf warrior from the previous example, lures one of his bugbear guards into his cell in another bid to escape. The guard is wary of trouble, so the DM rules there is no chance for surprise, but also gives Anada the first attack as he lunges from behind the door and grapples with the bugbear.

The bugbear is armed, and turns toward Anada as he attacks. Because Anada is threatened, the bugbear gets an attack of opportunity before Anada makes his wrestling attack. Anada gets lucky and the bugbear misses. Anada makes an attack roll vs. Armor Class 10 and rolls a 7, good enough to hit.

Now Anada checks to see if he achieves a hold. Anada and the bugbear make opposed attack rolls. Anada is attacking Armor Class 10 because the bugbear has no magical or Dexterity bonuses; Anada suffers a -4 penalty for being a size class smaller than the bugbear but gains a $+1$ bonus from his Strength. The bugbear is attacking Armor Class 8 because of Anada's *chain mail* $+1$ and 15 Dexterity. Anada rolls a 10, good enough to hit. The bugbear rolls an 18, also good enough to hit; however, Anada wins the opposed attack roll because he succeeded with a lower number. Anada has a hold on the bugbear and inflicts $1d2+1$ points of damage (because of a successful hold and Anada's 17 Strength). Anada inflicts 2 points of damage, both temporary.

During its attack phase, the bugbear drops its weapon, which is too big to use while grappled, and tries to break free. Anada and the bugbear conduct another opposed attack roll, this time with the bugbear gaining a $+4$ bonus to its roll for the size difference, since it is the attacker. The bugbear rolls a 20, normally good enough to score a critical hit against Anada's effective Armor Class of 8. Anada, however, rolls an 11, good enough to hit the bugbear's effective Armor Class of 10 and win the opposed roll (because it is success-

ful and lower than the bugbear's roll). Because the bugbear didn't win the opposed roll, the critical roll is disregarded; the bugbear does not achieve a lock on Anada.

Now that both combatants have taken an attack phase, the combat proceeds to the next combat round. Anada wins initiative and tries to achieve a lock on the bugbear. There is another opposed roll, and Anada wins with a roll of 12 versus the bugbear's 2 (the bugbear lost because its attack failed and Anada's succeeded). Anada achieves a lock and decides to hold the bugbear's mouth shut to keep it from calling for help. The DM decides this is a manipulation, and the bugbear suffers another $1d2+1$ points of damage. Anada inflicts 3 points of damage, all temporary.

The bugbear tries to free itself once again during its attack phase, but loses the opposed roll. The combat round ends.

During the next round, the bugbear wins initiative, but loses the opposed roll again. Now that the bugbear's mouth is clamped shut, Anada decides to twist the bugbear's head a little, which qualifies as a press. The DM decides Anada can keep hold of the bugbear's mouth while wrenching at its head, but Anada still must make another opposed roll to establish the press. Anada wins again and inflicts $1d6+2$ points of damage ($1d6+1$ for the press, plus one for Anada's Strength). Anada rolls a 4 and inflicts 6 points of damage, 1 normal and 5 temporary. The bugbear has now suffered 9 points of damage, 8 temporary and one normal. The bugbear started with 14 hit points, is now at 5, and struggles on.

Anada loses initiative the next round and the bugbear tries to free itself again. There is another opposed roll, which the bugbear loses. If the bugbear had won, both the press (head twist) and manipulation (mouth clamp) would have been broken and Anada would only have had a simple hold.

Anada decides to press again on his attack phase. There is another opposed roll, which Anada wins; because Anada was just holding on, the bugbear could not have achieved a lock by winning the roll with a critical hit. Anada has maintained his press through two attack phases, so he inflicts an extra point of damage, for a total of $1d6+3$ points. Anada inflicts 7 more points of damage, 1 normal and 6 temporary. The bugbear's hit point total is now below zero, and it falls unconscious for $2d6$ full turns. Anada picks up the bugbear's weapon and slips out of the cell.

Unarmed Combat



Overbearing This version of overbearing is an expanded version of the one appearing in Chapter Two, but it also assumes that no combatants involved are fighting with weapons. Overbearing includes most attacks aimed at simply overpowering the target. If the attackers are seeking to overwhelm the defender through brute strength or sheer weight of numbers, it's an overbearing attack. Overbearing is a tactic available to any creature and can be used against almost any other creature. Creatures with multiple legs are difficult to overbear. Creatures with no legs at all are nearly impossible to overbear (because they can't be knocked down) but attackers with sufficient strength sometimes can pin them in place. Creatures with no solid form (immaterial, gaseous, or liquid) cannot be overborne.

Characters need not have their hands free to make overbearing attacks, but they might not be able to take full advantage of pins if they do not (see below).

Overbearing Procedures

Virtually all creatures can make one overbearing attack each round. As explained in Chapter Two, overbearing requires an attack roll vs. Armor Class 10. Adjustments for Dexterity and magic apply to the defender's Armor Class.

If the attack hits, there is an opposed Strength roll to determine if the defender keeps her feet. A list of modifiers (expanded from Chapter Two) is included below:

- 4-point bonus or penalty per size difference of the largest attacker versus the defender;
- +1 bonus per additional attacker;
- -4 penalty if defender has more than two legs;
- -4 penalty if the defender is legless (snake, worm, slug);
- -4 penalty if the defender is generally amorphous (ooze, slime, jelly).*

*Creatures that qualify for this modifier also get the modifier for having no legs, for a total penalty of -8.

If the defender wins the opposed Strength roll, she stays on her feet and the attackers remain in their squares. The defender remains clear and can finish the round normally. If the attackers win, they (or as many as will fit) enter the defender's square and everyone falls in a heap with the attackers on top. The overborne character takes no damage. Note that attackers in

squares adjacent to the defender can contribute to overbearing attacks even if they can't enter the defender's square.

If defender is overborne, she loses all actions for the remainder of the round and her actions are severely limited the next round; the character is grappled and cannot move or make any attacks (including attacks of opportunity) until she gets free.

A defender who has been knocked down by an overbearing attack can be pinned if she is successfully overborne again in the following round. Overborne defenders can do nothing until the pin is resolved.

Pins

Attackers who have made successful overbearing attacks have an advantage over the defender in the following round. The attackers can release the opponent or try for a pin.

If the attackers release the opponent, they can immediately attempt another unarmed attack, draw a weapon and attack (this counts as a half-move action), or attempt some other action normally available to characters, such as movement.

If the attackers try for a pin, conduct another opposed Strength roll. If the attackers win, the opponent is pinned (see below). If the defender wins, the attackers must leave the defender's square and the defender can spend a half move or an attack to stand up, just as if she had suffered a knockdown.

Effects of Pins

A pin lasts for an entire combat round. A pinned character is considered prone and grappled. The attackers can immobilize a pinned character's limbs if their hands are free. If the attackers are the same size or larger than the defender, one of the defender's limbs is immobilized and useless for every attacker with free hands in the pile. If the attackers are smaller, it takes one extra creature per size class difference to immobilize a limb. For example, it takes one human to hold down an orc's arm, two humans to hold down an ogre's arm, and three humans to hold down a hill giant's arm. If the attackers are larger, they can pin two limbs for every two size classes difference. For example, a single ogre can pin one limb of a dwarf or two of a halfling's limbs.

If all the defender's limbs are immobilized for two consecutive rounds, the attackers have the upper hand and can choose any wrestling lock effect. (Damage from locks achieved through an overbearing pin is

Chapter Five



mostly temporary, as in all other forms of brawling combat.) A group that achieves a lock inflicts damage only once per round, but uses its effective group Strength score when determining damage.

Maintaining and Breaking Pins

A pinned creature can make unarmed or natural attacks with its free limbs or can attack with a size S weapon. The pinned character's original facing does not affect these attacks; all the characters involved are entangled in a random dogpile and the defender is assumed to be facing all the attackers simultaneously—this is one disadvantage to overbearing attacks. If the defender inflicts a critical hit with a weapon or natural attack, he can opt to inflict double damage (or roll for a special effect according to the rules presented in Chapter Six) or force the attacker who is struck to release her. If the defender scores a knockdown with a pummeling or weapon attack, the attacker who is struck must release the defender.

The attacker cannot directly counter the pin, she must wait until the attackers try to maintain the pin.

Attackers who have pinned a defender must make an opposed Strength roll each round to maintain the pin. If a pinned defender wins the opposed Strength roll, she breaks the pin and can spend a half move or an attack to stand up. She is still grappled, however. If the defender wins the next opposed Strength roll, she breaks free. If the defender wins initiative, she can force the roll herself on her attack phase; this is the only time a defender can initiate the opposed roll, which can be either an attack or a Strength roll, at the defender's option. If the defender loses or there is a tie, the defender remains grappled and the attackers can skip the attack roll and go directly to the opposed Strength roll on their next action phase. If the defender wins, she breaks free and can finish the round normally.

Assistance

Overbearing involves brute force and is the natural attack form for groups of creatures confronting a lone target. In the case of multiple defenders, the attackers can divide themselves among their opponents or concentrate on a single defender, provided that the attackers occupy squares adjacent to the defender.

The defender's allies, if clear, can remove attackers from the pile by making overbearing or wrestling attacks against them. An ally who threatens the attackers can make attacks of opportunity each time the attackers initiate an opposed roll—the arrival of an

armed ally usually breaks up a massed overbearing attack. A critical hit or knockdown can force an attacker to release a defender, as described above.

Missile attacks directed at a pile have a chance to hit any character in the pile as described in Chapter One.

Overbearing Skill Levels

Any creature or character who can be overborne is automatically familiar with overbearing combat. A character cannot choose to be nonproficient in overbearing and gain extra character points under the optional character point system from the *Skills & Powers* book.

Overbearing is a crude form of combat that emphasizes brute force over finesse. It is not possible to develop overbearing expertise, specialization, or mastery.

An Example of Overbearing

Anada, the elf warrior from the two previous examples, is sneaking through the bugbear lair with a morning star in hand. He still wears his *chain mail +1*. The bugbears are quick to note escape and three of them corner him in an unused chamber. The trio decides to rush Anada and take his weapon away.

The three bugbears make a combined overbearing attack against Anada. Because he is armed, Anada can make attacks of opportunity against the bugbears. As an 8th-level fighter, Anada is entitled to up to four attacks of opportunity, but he only gets three since there are only three bugbears. Anada gets lucky and hits all three times. No hits kill any bugbears, but he scores a knockdown chance against one of them. The bugbear fails its saving throw roll vs. death and is knocked down. It cannot participate in the overbearing attack. Even if the save was successful, the bugbear could not participate in the attack because it suffered a knockdown chance.

The two remaining bugbears must hit AC 8 (because of Anada's magical chain mail and 15 Dexterity). They hit, and there is an opposed Strength roll to see if Anada is overborne. The bugbears receive a +4 bonus because they are larger than Anada and an additional +1 because there are two of them; their effective Strength score for this attack is 19. Anada rolls a 16, higher than his adjusted Strength score. The bugbears roll a 13, easily a success. Anada goes down, with the bugbears on top, in the square where he stood. Anada can do nothing except await the bugbears' pin attempt.

Unarmed Combat



The next round, the bugbears attempt a pin. The third bugbear jumps on the pile, increasing the bugbears' bonus to +6. Anada rolls a 15, exactly what he needs to succeed with his Strength score. The bugbears roll a 10, a success, but Anada succeeded with a higher roll, so he wins. Because he was not pinned Anada can spend a half move regaining his feet and attack with his morning star. His blows do not slay any bugbears, and another bugbear enters the chamber and joins the fray.

All four bugbears attempt to overbear Anada during the next round. Anada gets an attack of opportunity against each of them and slays one. The three survivors make a combined attack and hit AC 8, forcing another opposed Strength roll. The bugbears win, and Anada goes down again. Once again, Anada can do nothing but await the pin attempt.

The three bugbears win the next opposed roll, pinning Anada. Both of Anada's arms and one of his legs are pinned. The DM decides that the bugbear holding Anada's leg is prone, and allows the elf to kick (pummel) that bugbear. Anada hits and scores a knockdown against the bugbear, making it let go of his leg.

The two remaining bugbears try to maintain the pin during the next round, and the bugbear who was knocked loose joins the pile. Anada wins the opposed roll. Because he was pinned, Anada can only regain his feet, he cannot break free or launch any other attacks.

Anada wins initiative, however, and can attack before the bugbears can do anything. His morning star is too large to use while grappled, so Anada decides to break free with an opposed attack roll (taking advantage of his superior THACO). Unfortunately, he rolls a 1 and fails. He will remain grappled no matter what the bugbears roll.

The bugbears try to overbear again; because Anada is grappled, he gets no attacks of opportunity and the bugbears do not have to make an attack roll. The bugbears win the opposed Strength roll, knocking Anada to the floor again.

By this time, two more bugbears arrive on the scene. The bugbears attempt to pin Anada during the next round and the new bugbears join the pile. They have a +8 bonus and handily win the opposed Strength roll. All of Anada's limbs are pinned.

The next round, they attempt to maintain the pin and succeed again. All of Anada's limbs have been pinned for two consecutive rounds, and the bugbears have him under control. Four bugbears pull Anada's arms and lock them behind his back while the fifth

bugbear ties them together (a manipulation). Anada suffers 1d2+10 points of damage from the manhandling (because the bugbears' effective Strength score is 22).

The five bugbears quickly haul their bound captive back to his cell, where they bind him even more securely.

Attack Options and Unarmed Attacks

Several attack options from Chapter Two are also available to unarmed characters, as follows:

- **Block:** A character can allocate one pummeling attack to block an incoming attack. Blocks vs. other unarmed attacks are resolved normally. Unarmed blocks against weapons, including creatures with natural weapons, receive a -4 penalty.
- **Called Shot:** A called shot to an opponent's head during unarmed combat is a sap attack and should be resolved according to the rules given in Chapter Two. Sapping requires a small, hard object. Barehanded sapping attacks are treated as normal pummeling attacks.
Most other called shots made during unarmed combat should be resolved as special attacks. Attempts to knock items out of opponents' hands, for example, should be treated as an offensive disarm.
- **Disarm:** An unarmed character can attempt both offensive and defensive disarms at a -4 penalty to his attack roll if he is eligible to make pummeling attacks. If an unarmed character attempts to disarm a two-handed weapon the attack penalty is -8. An unarmed offensive disarm always provokes an attack of opportunity.
- **Pull/Trip:** Most unarmed pull/trip attacks should be resolved as wrestling attacks.
An unarmed pull/trip can be resolved as a pummeling attack if directed at an opponent who is moving and unaware of the attack. Use the pull/trip rules from Chapter Two to resolve this maneuver.
- **Unhorse:** Treat unarmed unhorse attempts as overbearing attacks if the attacker could conceivably get her body onto the mount while attacking (as might be the case if the attacker were jumping down on the mounted character from a height); otherwise, resolve them as wrestling attacks.
- **Duels:** Two unarmed characters can conduct a duel if they are not involved in a wrestling sequence (the opposed rolls in a wrestling combat already reflect a

Chapter Five

contest of skill). If a successful grapple during any duel results in a hold, the duel is suspended until the resulting wrestling sequence ends. See Dueling in Chapter Two for procedures.

Subdual Attacks

It is possible to employ most common weapons in a generally nonlethal manner by striking only with the haft or flat of the blade. For some weapons, it is possible for the attacker to reverse his grip and use the weapon's butt or pommel as a club.

To make a subdual attack, a character makes an attack roll vs. the opponent's normal Armor Class. There is -4 attack penalty and the weapon's damage is reduced by half; round fractions up. Subdual attacks are treated as armed melee attacks in all other ways.

Characters who are entitled to multiple melee attacks can make multiple subdual attacks. All bonuses for Strength, expertise, specialization, and mastery apply to subdual attacks. Any damage inflicted is three quarters temporary, just as in brawling attacks. Creatures reduced to zero hit points or less fall unconscious just as in brawling combat. If you don't want to bother with dividing subdual damage in half, then dividing by four, roll a smaller die for damage instead. For example, roll 1d4 for a long sword, 1d3+1 for a footman's mace, and 1d4 for a morning star. A critical hit with a subdual attack causes a blunt critical effect (see Chapter Six) or forces the target to roll a successful saving throw vs. death to avoid being knocked out for 3d10 combat rounds. There is no saving throw adjustment for the attacker's Strength as there is in pummeling attacks.

An Example of Subduing

The hapless Anada finds himself forced into a gladiatorial combat by his bugbear captors. His opponent is Barzun, a 7th-level dwarf fighter. Anada decides he doesn't wish to kill his fellow prisoner and decides to attack to subdue instead. Barzun wears plate mail and carries a shield, giving her an Armor Class of 2. Anada wins initiative and rolls a 12. Anada's THACO is 13, so his roll is good enough to hit even before adding the $+1$ attack bonus Anada gets for his 17 Strength, but not good enough for a critical hit. The DM decides Anada should roll 1d4 to determine the morning star's subdual damage (but the DM could have decided to roll 2d4 and divide the result by two). Anada rolls a 3; Barzun suffers 4 points of damage ($+1$ for Anada's Strength). Three points are temporary and 1 point is normal.

Barzun decides to reply with a subdual attack as well. Anada's Dexterity and *chain mail* $+1$ give him an Armor Class of 3. Barzun rolls a 10. Her THACO is 14, making her roll barely good enough to hit after

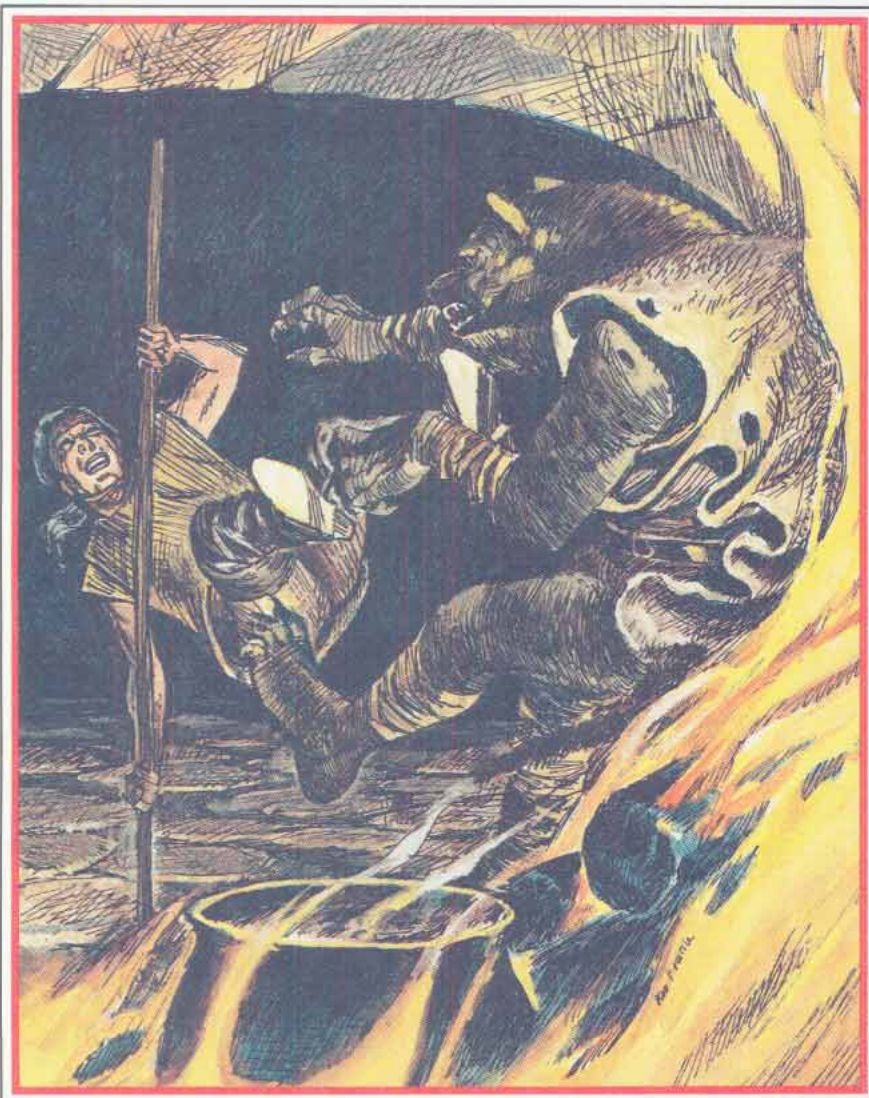

Unarmed Combat

adding the +1 attack bonus from her 18/21 Strength. Barzun rolls a 2 for damage; she adds +3 for her Strength and inflicts 5 points on Anada, 4 temporary and 1 normal.

Anada wins initiative again and declares a no-move attack. He attacks once with his morning star in the average phase and again in the slow phase (because he is 8th level and entitled to an extra melee attack this round). Barzun also declares a no move attack and gets attacks in the average and slow phases. Because she lost initiative, Barzun strikes last in each phase. Anada's first attack hits with a 15. There is no chance for a critical hit, and he inflicts 4 points of damage again (3 temporary and 1 normal). Barzun misses her attack, and combat proceeds to the next phase.

Anada hits again and inflicts 5 points of damage. Barzun has now suffered 13 points of damage (10 temporary and 3 normal). Barzun's final attack hits with a 20. She only needed to roll a 10, so the 20 is good enough for a critical hit. Anada suffers 2d4+3 points of damage (the morning star's 1d4 subdual damage is doubled to 2d4 and Barzun's +3 damage bonus is added). Barzun rolls a 6, inflicting 9 points of damage, 7 of which are temporary and two that are normal. Anada has now suffered 14 points of damage, 11 temporary and 3 normal. Barzun opts to knock out Anada rather than rolling for a critical hit. Anada rolls a 2, failing his saving throw vs. death; he will be unconscious for 3d10 combat rounds and the gladiatorial fight ends, much to the bugbears' disappointment.

Martial Arts Martial arts is a specialized form of pummeling that uses the body as a weapon. A creature must be able to make pummeling attacks to employ a martial art.

Martial arts are difficult to learn and not commonly known. Generally, only creatures with at least *average* intelligence and from mediative, nonmaterialistic cultures can learn martial arts.

Martial arts requires at least one free hand. Unlike a character making normal pummeling attacks, a martial artist must be bare-handed or wearing only normal gloves and shoes. A martial art is a discipline of the mind and body and most implements are avoided. Improvised weapons cannot be used in martial arts attacks.

Martial arts attacks inflict mostly temporary damage, just as normal pummeling attacks do. Martial arts attacks are ineffective against creatures normally immune to pummeling attacks.

Martial Arts Procedures

Except where noted below, martial arts attacks are resolved as pummeling attacks. A martial artist enjoys some advantages while pummeling, depending on the style of martial arts he is using:

- **Style A:** The style emphasizes striking with the hands or fists. The character's bare or gloved hands are treated as small, hard objects (1d3 points of damage), and the character can strike and damage creatures of any size. If the character is unarmed and unarmored, he can make an extra attack each round with his other hand (provided that it is free) without the usual penalties for attacking with two weapons.
- **Style B:** The style emphasizes striking with the feet. The character's bare or shod feet are treated as large, hard objects (1d6 points of damage), and the character can kick opponents even when they are not prone, sitting, or kneeling. If unarmed and unarmored, the character can make an extra attack each round with one of his free hands. Note that the ability to pummel creatures of any size is not part of this style.
- **Style C:** The style emphasizes throws and escapes. The character can choose the pull/trip combat option when making pummeling attacks. If the attack hits, the martial artist can use either his Strength or Dexterity score for the opposed roll. The martial artist also can make an opposed attack roll to escape any hold, grapple, lock, or pin. The escape roll counts as an attack, but if it succeeds the martial artist is considered clear and can finish the round normally.
- **Style D:** The style emphasizes dodges and blocks. The character can make one free block each round in addition to any attacks he makes. If unarmed and unarmored, the character receives a -2 Armor Class bonus.

Martial Arts Skill Levels

- **Nonproficient:** Any character who has not been trained in one of the four martial arts styles automatically falls into this category. Nonproficient martial artists can make normal pummeling attacks, but cannot claim any martial arts benefits.
- **Familiar:** Familiarity has no effect on the martial arts; a character is proficient in a martial art or he is not.
- **Proficient:** Martial arts styles are unknown in most AD&D game lands. To spend character points (or a weapon proficiency) to become proficient in a mar-

Chapter Five



tial arts style, a character must be native to (or have paid an extended visit to) a culture where martial arts has developed. Such cultures are usually non-western, philosophical, and nonmaterialistic. They usually stress the power of nature or of the inner self over the power of tools, weapons, and technology. Such cultures often do not allow commoners to own weapons or armor.

Proficient nonwarriors can make one martial arts attack each round. Proficient warriors gain their full allotment of melee attacks when making martial arts attacks. If a character has sufficient character points (or proficiency slots) available, he can become proficient in more than one martial arts style. All benefits are cumulative; for example, a character proficient in styles A and B could kick or punch creatures of any size, inflicting 1d3 points of damage with a punch and 1d6 points of damage with a kick. If unarmored, the character could make one extra punch each round with no penalties. Note that the four martial arts styles do not constitute a weapon group; each must be learned separately.

- **Expert:** Any character who knows a martial arts style can spend character points (or weapon proficiencies) to become expert in the style. (Characters proficient in multiple martial arts styles can become experts in only one style.) Expert warriors who are entitled to more than one melee attack each round can make the same number of martial arts attacks each round, but gain no other benefits. Expert nonwarriors can make multiple martial arts attacks at the same rate as a nonspecialized warrior of the same level.
- **Specialized:** Generally, only single-classed fighters can become martial arts specialists, though there are optional rules in the *Skills & Powers* book that allow other characters to specialize. Martial arts specialists gain the normal specialist attack and damage bonuses and extra attacks. Specialists' attack bonuses apply to their Strength scores when rolling for knockdowns. Characters proficient in multiple martial arts styles can become specialists in only one style. Martial arts specialists can make martial arts attacks against armed opponents without provoking attacks of opportunity. Specialists can attempt blocks and disarms against armed opponents without the -4 penalty to the opposed roll; martial arts disarms against two-handed weapons receive a -4 penalty instead of the normal -8 penalty for unarmed disarms.

- **Master:** Only single-classed fighters can attain mastery in martial arts. Martial arts masters gain the normal master attack and damage bonuses and extra attacks. Masters' attack bonuses due to their Strength scores apply when rolling for knockdowns, and apply to opponents as penalties to saving throw rolls vs. knockouts. Grand master martial artists can use critical augmentation to score knockouts on attack rolls of 16 or better.

A martial arts master threatens his front squares and is entitled to make attacks of opportunity just as if he were armed with a weapon. A martial arts master can choose to inflict normal damage instead of mostly temporary damage. If the master rolls a critical hit while inflicting normal damage, he scores a bludgeoning critical instead of a knockout chance. When determining severity, compare the master's size class with the target's. Reduce the master's size class by one category if the attack is a punch.

Martial Arts Weapons

There are a few weapons specifically designed for use in the martial arts. Most of these weapons were originally improvised from common tools, but have been refined to function as extensions of a martial artist's body. Chapter Seven includes a list of these weapons.

A martial arts weapon functions normally in most respects. A character chooses it and learns to use it as he would any other weapon. A martial artist armed with a martial arts weapon can use his style's special abilities even if they normally require him to be unarmed. The martial artist can employ the weapon in combat to avoid provoking attacks of opportunity and other penalties associated with being unarmed. For example, a character proficient in style A martial arts could use a nunchaku in each hand, inflict 1d6 points of normal damage with each hit, and avoid attacks of opportunity. A character proficient in style B could use a nunchaku and still claim his Armor Class bonus if he is unarmored; the character could use the nunchaku to perform his free block without the -4 penalty for being unarmed.

Martial artists are still subject to the normal nonproficiency penalties when using martial arts weapons. Nonspecialist martial artists still provoke attacks of opportunity if they make unarmed attacks while armed with a weapon, even a martial arts weapon. For example, a kick from a character proficient in style B could provoke an attack of opportunity even if the martial artist was holding a nunchaku at the time.

Unarmed Combat

An Example of Martial Arts Combat

Anada, the elf fighter from previous examples in this chapter, is finally rescued from the clutches of his bugbear captors. His next adventure takes him to a distant land he has never visited before. Anada returns to his campsite one morning to discover a motley trio of humans helping themselves to his rations. He shouts and charges, waving his sword high. To Anada's surprise, the unarmed brigands stand their ground.

Anada wins initiative and attacks first; he rolls a 15 and easily hits his unarmored opponent (though there is no critical hit). The brigands are proficient in type B martial arts. They are hungry and decide to kick and punch. The kicks provoke attacks of opportunity from Anada, but the punches do not because a single character can make only one attack of opportunity against a given opponent in one combat round. All of Anada's attacks hit. The brigand wounded earlier by Anada drops to the ground, reduced to less than 0 hit points. Anada rolls an 18 against the second brigand, more than enough for a critical hit. Anada inflicts $2d8+1$ points of damage and decides to foil the brigand's attack rather than rolling for a slashing critical. Anada merely wounds the third brigand, who can complete his attack. The brigands are 2nd-level fighters (THACO 19). The brigand rolls a 17, good enough to hit Anada's Armor Class of 4. (Anada still has his 15 Dexterity and *chain mail* +1, and he has picked up a shield, which improves his Armor Class to 2. However, he suffers a +2 Armor Class penalty for charging.) The kick inflicts 4 points of damage, 3 temporary and 1 normal. To see if there is a knockdown, Anada and the brigand must make an opposed Strength check. The brigand's Strength is 14 and he gets a +1 for attacking with a large object (his foot is treated as one because he is using style B). Anada's Strength of 17 is unmodified. Anada wins the opposed roll and is not knocked down. Now the two brigands make their punching attacks, and both miss.

The next round, the wounded brigand retreats, leaving his comrade to face Anada alone. The brigand decides to block and Anada declares an attack. Anada wins initiative, but the brigand still can block because the block was declared before the initiative roll. The brigand announces that he's blocking the sword with his arm. There is an opposed roll; the brigand makes an attack vs. Armor Class 4, with a -4 penalty for an unarmed block vs. a weapon. Anada makes an attack roll vs. the brigand's Armor Class of 10. The brigand rolls a 19 and Anada rolls a 20. The brigand succeeds

in spite of the penalty. Anada has succeeded, too, but the attack is blocked because the brigand succeeded with a lower roll (just Anada's luck). Because the brigand is entitled to two attacks (a kick and a punch), he could attack with a kick now (because he's already used his punch to block Anada's sword). The brigand decides he doesn't want to suffer another attack of opportunity and doesn't attack.

Anada is entitled to two attacks as well (because he is an 8th-level fighter), and he swings his sword on the next action phase. The brigand decides to allocate his second attack as another block. The DM considers the situation for a moment, since he's not sure it's possible to block a sword with a kick. The DM decides to allow the block because the brigand is trained in a martial art. There is another opposed roll, which the brigand loses. The damage is enough to put the brigand under 0 hit points. The brigand who retreated earlier flees, and Anada has won the confrontation.

Martial Arts Talents

Once a character is proficient in at least one martial arts style, she can acquire, with the DM's approval, a variety of additional skills that reflect her advanced mental and physical training. Only a martial artist can learn the skills presented here. They can be purchased with either weapon or nonweapon proficiency slots.



Chapter Five



Flying Kick (1 slot/3 CP)

Groups: Warrior

Strength/Muscle

Initial rating: 5

The character can leap high into the air, leading with a powerful kick that can strike opponents up to three squares away. The character can land in any square adjacent to the target, as long as it is within two squares of the attacker's starting position. If the character is not proficient in style B, this maneuver is the only attack she can make in the round, and the kick inflicts 2d4 points of damage. Strength bonuses to the attack and damage rolls apply, but specialization and mastery bonuses from another martial arts style do not.

If the character is proficient in style B, this maneuver can replace one kick attack each round, and the kick inflicts 2d6 points of damage. Strength bonuses apply to the attack and damage rolls. If the character is a style B specialist or master, the appropriate bonuses also apply.

If the character has at least one square of running room and declares a half move action, no ability check is required. If the character has no running room or declares a no move action, a Strength/Muscle check is required. If the ability check fails, the attack automatically misses as the character falls down in her landing square.

Backward Kick (1 slot/ 3 CP)

Groups: Warrior, Priest, Rogue

N/A

The character can attack an opponent standing in one of her rear squares either by lashing backward or kicking over her own head. This maneuver does not provoke attacks of opportunity (but deliberately turning one's back on an opponent does). This maneuver works best for characters proficient in style B, similar to the flying kick described above.

Spring (1 slot/3 CP)

Groups: Warrior, Rogue

Dexterity/Balance

Initial rating: 5

The character can make astonishing jumps and leaps with blinding speed. At the cost of a half move or an attack, the character can spring into the air, attaining a height of five feet and landing up to two squares away in any direction. The character can flip and twist while airborne to achieve any facing when he lands. If the character has a 2-square running start, he can double his springing distance, landing up to four squares away and leaping 10 feet in the air, but the running start is a half-move action. For every additional slot spent on this skill, the character can add five feet and one square to the distance achieved.

For example, a character who has spent two slots on this skill could leap 10 feet into the air and land up to three squares away from a standing start. If the character's Dexterity/Balance roll fails, the character falls down in his landing square; he can get up during his next action phase, but can take no other actions until the following round. If the ability check succeeds, the character can finish the round normally after landing.

Crushing Blow (1 slot/3 CP)

Groups: Warrior, Priest, Rogue

N/A

The character can break hard objects with her hands (or feet if she uses style B). Under ideal conditions, the character can break a wooden board $\frac{1}{2}$ " thick per level or $\frac{1}{4}$ " slab of stone or brick per level. Objects that are exceptionally strong, reinforced, supported by other objects (such as bricks in a wall), or not shaped like boards receive a saving throw roll vs. crushing blow to avoid breakage. When used against a creature, the crushing blow does normal damage plus 1 point per level. A crushing blow requires intense concentration. It is a no-move action, and the character can take no other actions during the round when she uses the crushing blow.

Instant Stand (1 slot/3 CP)

Groups: Warrior, Priest, Rogue

Dexterity/Balance

Initial rating: 7

The character can instantly regain his feet after falling down. If the ability check succeeds, the character can ignore the effects of knockdowns or failed spring attempts. If the ability check fails, the character can get up during his next action phase, but cannot take any further actions until the next round. Characters cannot use this skill while pinned, locked, held, or grappled.

Missile Deflection (1 slot/3 CP)

Groups: Warrior, Priest, Rogue

N/A

The character can perform block maneuvers (see Chapter Two) against normal missiles fired at her from the front. The character can use her free change of facing (see Chapter One) to turn toward an attacker firing missiles from her flank or rear, but this counts as her change of facing for the round.

Normal missiles include mundane and enchanted arrows, axes, bolts, javelins, small stones, and spears. Large or magical missiles, such as ballista bolts, hurled boulders, and *magic missile* spells, cannot be deflected.

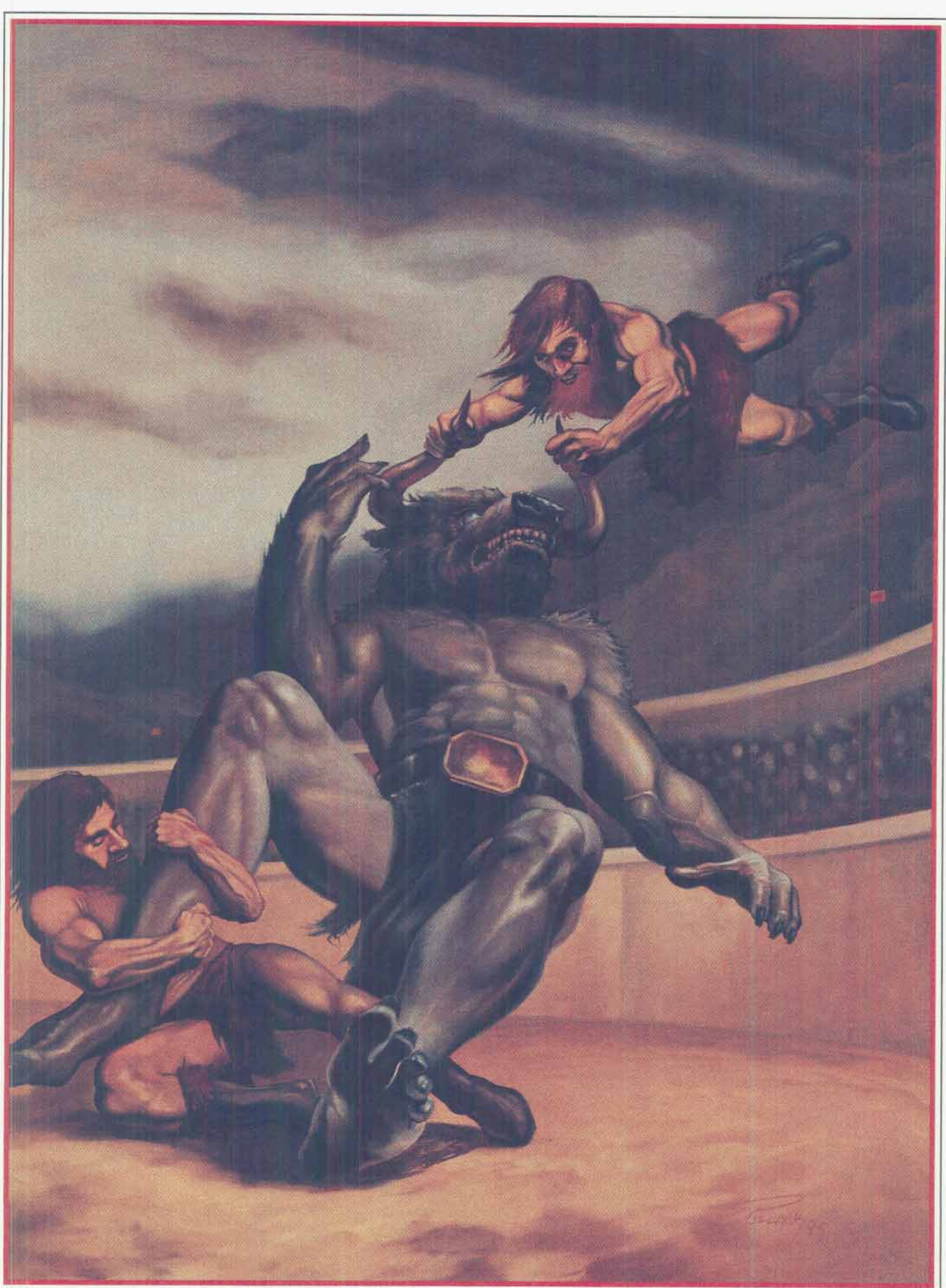

Chapter Six: Critical Hits



Fantasy literature is full of mighty blows and grievous wounds that change the course of a battle. Characters such as Robert E. Howard's Conan, Beowulf, or any of the heroes of the Arthurian legends wreaked havoc among their enemies—cleaving skulls, severing limbs, and otherwise smashing their foes into red ruin. Every fan of heroic fiction is a little fascinated (and sometimes horrified) by blood and gore. You only have to go out to the movies to see that this is true.

However, the purpose of this chapter is not to overwhelm AD&D players with sickening displays of pointless violence. The purpose of this chapter is to provide the AD&D game with a more realistic system for simulating telling blows and specific injuries. At its most basic level, the AD&D combat system is a contest of attrition that all boils down to who runs out of hit points first. Critical hits can change that.

This chapter presents two critical hit systems. The first is extremely simple: if you score a critical hit, you get to roll double damage. The second system is more involved and takes into account the location of the injury, the severity of the wound, and the power of the attacker. Last (but certainly not least!) this chapter concludes with a few notes on the effects of specific injuries and how they can be healed.

Does This Belong in My Campaign?

While the rest of this book assumes that you'll be playing with the full critical hit tables and rules, you'll find that this chapter can be completely disregarded with no ill effects. More than anything else in this book, critical hits are *optional*; if the DM and players don't want them, the AD&D game works fine without them.

However, there is one thing worth mentioning: if monsters have to suffer critical hits, so do player characters. Otherwise, game balance quickly goes out the window.

Critical Hits



Critical Hits: System I

Critical hits occur when a character rolls a natural 18 or higher *and* hits the target by a margin of 5 or more after all adjustments. If the character scores a critical hit, he inflicts double damage *dice*, calculated before adjustments for Strength, magic, or special circumstances. In a situation where the damage is doubled for another reason, do not double the multiplied damage; add it instead, then add other adjustments. For example, a light lance inflicts 1d6 damage, or 2d6 in a charge. But if a charging lancer scores a critical hit, the lance inflicts 3d6 damage, not 4d6.

For example, Liera is a 4th-level elven warrior fighting a gnoll. Liera's base THACO is a 17, but she has a 17 Strength (+1 to hit), she's an elf using a long sword (+1 to hit), and she has a magical long sword +2. Her total adjusted THACO is 13, and the gnoll's Armor Class is 5. She will hit the gnoll on a roll of 8 or better, and can achieve a critical hit with a natural 18 or higher. On one combat round, she rolls a 19, which is a critical hit. She rolls 1d8 for damage, doubles that, then adds +1 for her Strength and +2 for her magical long sword, for a total of 15 ((6×2=12)+1+2).

After dispatching the gnoll, Liera finds herself facing a horrible tanar'ri with an AC of -3! She scores a hit on a roll of 16 or better. She cannot score a critical hit because it's impossible for her to hit with 5 points to spare; even if she rolls a 20, she only hits by 4. If the tanar'ri charged, its AC would drop by one point to -2, and then Liera could score a critical hit with that roll of 20.

There are no specific injuries using this critical hit system. Instead, it only provides characters and monsters the chance to dish out extra damage when they make a great attack roll. Limiting the critical hits to attacks that hit by a margin of 5 or more solves one other problem. Consider the 1st-level fighter. He only hits on a 20 against an opponent with very good

Armor Class (0 or lower). Under other critical hit systems, the few times he *does* hit, the fighter *automatically* inflicts a critical hit. Under this system, that can't happen.

Critical Hits: System II

The second, and more detailed, system for critical hits uses the same attack mechanic as the previous one. As above, the attacker must roll a natural 18 or higher *and* hit his opponent by a margin of 5 or more. Then, if the victim fails a saving throw vs. death, a specific injury occurs. However, the effects are determined by four factors: the attacker's weapon size compared to the defender's size, the type of weapon compared to the type of target, the location of the hit, and a roll for the injury's severity.



Chapter Six



Critical Hit Charts

There are three types of weapons: slashing, piercing, and bludgeoning. Every weapon in the AD&D game system is assigned a type, with only a couple of exceptions such as lassoes and nets. If a weapon does not have a type, it cannot roll on a critical hit chart, although it can still inflict double damage on a critical attack roll.

These three weapon types are compared to three target types, for a total of nine different critical hit charts. The target types are humanoids, animals, and monsters. In the following pages, you'll find a chart for Bludgeoning vs. Humanoids, Bludgeoning vs. Animals, Bludgeoning vs. Monsters, Slashing vs. Humanoids, and so on. In most cases the correct critical hit chart to use should be relatively obvious.

Humanoids include anything that is generally shaped like a human, ranging from pixies to giants. If it has two arms and two legs, it's probably humanoid.

Animals include anything that is a normal or giant-sized version of a normal animal. Mammals, reptiles, birds, and amphibians all fall into this category—but not insects or fish. It also includes monsters that are animal-like in form, such as blink dogs, winter wolves, moon dogs, hell hounds, nightmares, osquips, or fire toads.

Monsters include anything that doesn't fit into the previous two categories. Giant insects of any kind, fish-like monsters, composite creatures such as manticores or dragons, and weird things like xorn or leucrottas would all be considered monsters. If in doubt over whether something is a monster or not, call it a monster; this is the default category for things that defy classification.



Critical Hits



Location

The critical hit charts require two die rolls: one to determine the location of the hit, and the other to determine the severity. Note that these can be rolled simultaneously. The location die is usually a single d10, but there are some exceptions.

Called Shots. If a character hits with a called shot and scores a critical hit, the location die is ignored. The location is automatically determined to be wherever the character had been aiming.

Low Attacks. If the attacker is fighting a creature two sizes larger or a defender with a distinct height advantage, use a single d6 for location. Head and upper torso shots become extremely unusual in these cases.

High Attacks. If the attacker is two sizes larger than the defender, or has a significant height advantage, roll 1d6+4. Giants fighting halflings don't often strike them low.

Severity

The second roll on the critical hit charts is for severity. The severity of a hit is determined by the relative size of the attacker's weapon and the defender.

Weapon vs. Target Size	Effect	Di(c)e
Weapon size is < target size	Minor	1d6
Weapon size is = target size	Major	2d4
Weapon size is > target size	Severe	2d6
Weapon is two sizes larger	Mortal	2d8

The di(c)e indicated is the type rolled for that severity. For example, if a human armed with a long sword (size M) is fighting a gnoll (size L), he rolls 1d6 for the critical hit's severity because the long sword's size is smaller than the gnoll's size.

If the weapon is two sizes larger than the target, it is possible to reach the 13+ column of the chart. These hits inflict *triple* damage dice, even if the victim passes his saving throw to avoid the effects of the critical hit.

The arrows and bolts fired from bows and crossbows are considered size M weapons, even though the missiles themselves are Small. Heavy crossbow bolts are considered size L.

Resistance

Critical hits automatically inflict double damage dice, or triple damage dice if the weapon is two sizes larger than the target (see above.) However, any effects

beyond this can be avoided by a successful saving throw vs. death. For example, the critical roll may indicate an arm injury with minor bleeding, but if the victim makes his saving throw, no arm injury actually takes place. The character only suffers double damage from the hit. Obviously, this could be sufficient to mortally wound or kill a character anyway.

Some monsters are naturally resistant to the effects of certain critical injuries. Creatures such as golems, undead, or elementals don't bleed and therefore ignore any such effects. A monster like a hydra can lose a head without being instantly slain. However, these injuries can still be important because it might affect the way a monster moves or attacks. A skeleton that's had a leg knocked off can't move at its full rate, even if it is less troubled by the injury than a living person would be. Slimes and jellies have no parts that are more specialized or important than the rest of the body, and are therefore immune to the effects of most critical hits. Use common sense to handle these situations as they arise.

Reading the Critical Hit Tables

First, find the appropriate table for the weapon type (slashing, piercing, or bludgeoning) and the target type (humanoid, animal, or monster.) Then roll for hit location (d10) and severity (variable dice.) Refer to the entry indicated on the chart. Remember, critical hits inflict double (or triple) damage dice, but any other effects can be avoided by a successful saving throw vs. death.

The specific types of injuries are described in the section following the charts.

Specific Injuries

The critical hit charts include a number of specific injuries that go beyond a simple loss of hit points. Wounds are divided into five degrees of severity: *grazed*, *struck*, *injured*, *broken*, and finally *shattered*, *severed*, or *crushed*.

Wounds should be recorded on the character sheet. Attack and movement penalties remain until the injury that created the penalty has healed. Wounds are always accompanied by some loss of hit points, but a specific injury isn't damage *per se*; consider it a temporary penalty that the character has to put up with until it is restored.

For example, Feodor the Bold is fighting an ogre armed with a club. The ogre scores a critical hit, rolling a 6 for location and a 7 for severity. Feodor's torso has

Chapter Six



been struck, a wound that reduces him to $\frac{1}{2}$ his normal move and gives him a -2 penalty to any attack rolls he makes. (It also puts a healthy dent in his nice plate mail.) Feodor's penalties remain until he recovers from his "torso struck" specific injury.

Let's say that Feodor had 16 hit points, and the ogre's blow inflicted 12 points of damage. The missing 12 hit points can eventually be recovered, but Feodor's penalties remain until the "torso struck" specific injury heals.

Severe injuries can temporarily reduce a character's maximum allowable hit points. In other words, a fighter with a broken leg will not be allowed to enjoy his full allotment of hit points until his broken leg is repaired. If the character has more hit points than he is currently allowed, he is reduced to the injured value when the current battle is over. This represents the increased vulnerability of badly wounded characters.

For example, if a fighter with 30 hit points receives 10 points of damage and an "arm destroyed" injury that reduces him to 50% of his normal hit points, he drops from 20 to 15 when the battle is concluded and remains at 15 until his ruined arm is somehow healed. Remember, though, that specific injuries are only inflicted if the victim fails a saving throw vs. death.

Grazed: Grazes are minor injuries that may prove troublesome if they bleed. A *cure light wounds* spell or other healing magic capable of restoring 4 hp will heal a graze. (The *cure light wounds* spell doesn't have to actually restore that many points; it just must be capable of doing so.) Grazes also heal naturally as if they were a loss of 1d6 hp. In other words, if a graze is the equivalent of a 3-hp wound, two days of rest heal it completely, since characters normally recover 2 hp per full day of rest. Note that the graze isn't tied to the character's actual loss of hit points in any way. If a grazed character receives healing magic, the graze is healed and he gets to recover hit points.

Struck: A body part that has been struck is often penalized in a small way for the effects of the wound. For example, a critical hit that reads, "weapon hand struck, -2 penalty to attacks," means that the character has a -2 attack penalty with his weapon hand until the wound is healed. Injuries of this type can be healed by a *cure light wounds* spell or other healing magic capable of restoring 5 hp of damage. Struck areas heal naturally as if they were a loss of 2d6 hp.

Injured: Wounds of this severity can trouble a char-

acter for weeks; they heal naturally as if they were a loss of 10d6 hp. A *cure serious wounds* spell or other healing magic capable of restoring 10 hit points can also repair the injury. Injuries almost always entail serious combat penalties for the wounded character.

Injured arms, legs, or tails reduce a character to 75% of his normal hit points. An injury to the abdomen, torso, or head reduces a character to 50% of his normal hit points. A 25-hp character with a chest injury can have no more than 13 hit points until his injury is healed (and could have a lot less than that if he continues to suffer damage!)

Broken: Broken bones run the gamut from minor fractures that don't hinder a character at all to life-threatening compound fractures. Generally, the previous two injury categories are considered to include minor breaks or cracks; this category is reserved for severe fractures. Broken bones can be mended by a *cure serious wounds* spell that is devoted just to knitting the bone; unlike *grazed*, *struck*, or *injured*, the character regains no hit points from a spell used in this way. Broken bones heal naturally as if they were 20d6 lost hit points, so bed rest in the care of a proficient healer is a really good idea if the injured character is planning on resuming his adventuring career anytime soon.

Broken arms reduce a character to 75% of his normal hit points. Broken ribs or legs reduce a character to 50% of his normal hit points. Any other broken bones reduce a character to 25% of his normal hit points.

Crushed, Shattered, or Destroyed: Limbs that suffer this kind of catastrophic injury may never be usable again; hits to the torso, abdomen or head of this magnitude are often lethal. If the victim survives, he will never naturally recover to his normal self. A limb damaged this way will be useless for the rest of his life, and hits anywhere else will leave the victim incapacitated. The victim will be bedridden for at least one to eight months before he can even regain a semblance of mobility.

A *cure critical wounds* spell or other healing magic capable of restoring 20 hp of damage can repair the damage of this kind of injury. In addition, the bones of the affected area (if any) are assumed to be broken and may require another application of healing magic to repair.

Destroyed shoulders, hips, or limbs reduce the victim to 50% of his normal maximum hit points. Any other wounds of this magnitude reduce the victim to 25% of his normal total.

Severed: Obviously, a creature that has a limb severed can no longer engage in activities that require the

Critical Hits

use of that member. A human with a severed leg can't walk or run and is reduced to crawling until he gets a crutch. A character with a severed shield-arm can't use a shield anymore, and so on. The only way to undo this kind of damage is by means of a *regeneration* spell.

The shock of losing a limb will prevent a character from moving independently or attacking for 2d10 weeks. At the DM's discretion, a character who "only" loses a hand or a foot may actually be able to perform limited activities after being stunned 1d6 rounds, but only by passing a System Shock roll. However, characters who sustain such massive injuries are best off abandoning the field to their enemies.

The loss of a limb will reduce a character's maximum normal hit points by 25% for a partial loss, or 50% for a more catastrophic loss. If the character can compensate with a wooden leg or hook, the hit point loss may be reduced by one step.

Critical Hit Effects

There are several possible effects of injuries caused by critical hits: bleeding, attack penalties, movement penalties, knockdowns, dropped weapons or shields, and possible armor or shield damage. Some of these conditions are temporary—a dropped weapon can be picked up—while others remain until the injury that created the effect is healed. Any damage or other types of effects are marked off during the End-of-Round step if the **PLAYER'S OPTION** combat system is also used.

Bleeding: A character with minor bleeding loses an additional 1d2 hp per full turn until the wound is magically healed or bound. In addition, there is a chance that minor bleeding will stop on its own. The character may roll a saving throw vs. death each time he suffers damage from minor bleeding; if he is successful, the bleeding stops.

Anybody can stop minor bleeding by applying a bandage or otherwise addressing the injury. This takes 1d6 combat rounds or a single one-

minute round.

Major bleeding results in a loss of 1d2 hp per combat round until the wound is magically healed or bound. Left untreated, major bleeding can easily cause a character's death. In effect, the -10 rule represents major bleeding; the character loses 1 hp per round when reduced to negative hit points.

Major bleeding can be stopped by a *cure light wounds* spell (the victim recovers hit points, too), the healing of 5 hp of damage by any other magical means, or by a successful use of the healing proficiency. If the wound is bound by an untrained character, make an Intelligence check for the would-be medic. If he fails, he is unable to help. If he makes the check, the bleeding is reduced to minor.

Severe bleeding causes the victim to lose 10–60%



Chapter Six



(1d6×10%) of his original hit point total every combat round. For example, if a fighter normally has 43 hit points but receives a severe bleeding result, he loses 4 hp (10%) to 24 hp (60%) in each round of severe bleeding. Needless to say, this is extremely lethal.

A *cure light wounds* spell (or 5 hp of healing) will reduce severe bleeding to major bleeding; a *cure serious wounds* spell (or 10 hp of healing) reduces it to minor bleeding; and a *cure critical wounds* or *heal* spell stops it altogether. An untrained character has no chance to bind a torso, abdomen, or head wound with severe bleeding, but a successful use of the healing proficiency with a -4 penalty reduces severe bleeding to major bleeding.

Note that once a character drops below 0 hit points, regardless of the number and combination of wounds she is suffering from, she *only* suffers the effects of major bleeding (i.e., only 1 hit point is deducted per round).

Attack Penalties: Many critical hits hamper the victim's ability to fight, resulting in an attack penalty. This is noted as applying to all attacks or to attacks with the particular limb that was injured. Other critical hits may prevent the victim from making attacks at all. If a critical hit prevents a character from making attacks, it also prevents him from casting spells or exercising any other combat action except moving or using magical items.

Movement Penalties: Hits to the legs and body may penalize a character's ability to move. Usually, this is expressed as "½ move", "¼ move", and so on. If the character's movement is limited, he may not charge, run, or sprint; he can only move by using the reduced rate. A character with no movement at all can still ride a mount with difficulty, or drag himself on the ground with an effective movement rate of 1.

Knockdowns: If a critical hit calls for a knockdown, the victim is still entitled to a saving throw to avoid falling down. See Knockdowns in Chapter One.

Armor and Shield Damage: Some critical hits call for possible damage to a creature's armor or shield. If the victim of the hit has no armor at that location, the blow is usually assumed to have more severe effects than if the character was protected. The armor descriptions in Chapter Seven deal with the coverage of each type of armor.

If the creature struck does have a shield or armor to deflect the blow, it may be damaged if the chart calls for it. First of all, the victim gets his normal saving throw roll to avoid the effects of the critical hit; if the roll is successful, there is no special effect for the hit. If the roll fails, his armor or shield must roll an item saving throw vs. normal blow with the number of points of damage (before doubling) used as a negative modifier for the save. If the attacker's weapon is larger than the defender (for example, a Size L halberd striking a Size M human), the save is rolled against a crushing blow, instead.

For example, remember the ogre's critical hit on poor Feodor? That result also called for possible armor damage. The ogre's club is Size L, so the item saving throw is against a crushing, not a normal, blow. Feodor is in metal plate mail, which has a saving throw of 7 vs. crushing blow. The ogre did 6 points of damage before doubling for the critical hit, so Feodor's armor is safe on a roll of 13 or more on a d20.

A damaged shield is useless. If armor is damaged, only the location struck is useless, and it no longer contributes to the overall AC of the suit. Refer to the rules for Partial Armor in Chapter Seven. In the example above, Feodor was struck on the torso. If his armor failed its item saving throw, only his breastplate would be ruined. A plate mail breastplate contributes 3 points to his AC, so Feodor's AC worsens from AC 3 to AC 6. Damaged equipment can be repaired by a skilled armorer or by magical means.

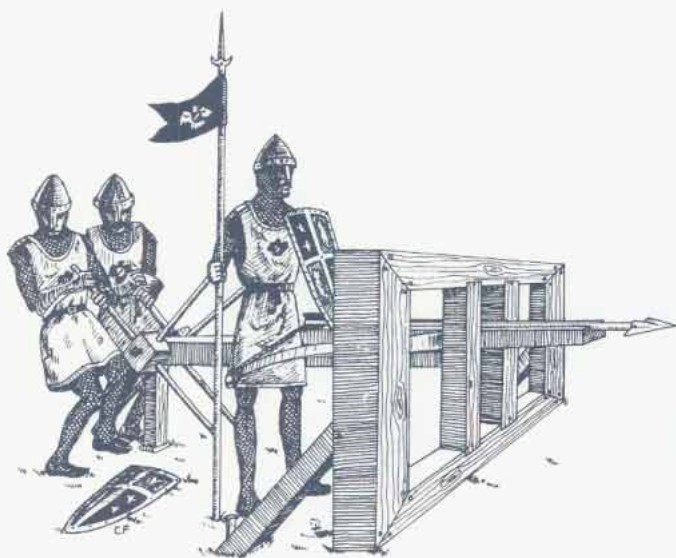

Critical Hits



Bludgeoning vs. Humanoids

Hit Location Chart

d10 roll	Location
1-2	Right leg
3-4	Left leg
5	Abdomen
6-7	Torso
8	Right arm
9	Left arm
10	Head

Location: Legs (Right 1-2, Left 3-4)

Severity	Effect
1-3	No unusual effect
4	Victim knocked down
5	Knee struck, knockdown, ½ move
6	Foot broken, ½ move
7	Armor damaged, leg injured if target has no armor to cover legs, ¼ move
8	Hip broken, minor bleeding, no move
9	Armor damaged, leg broken if target has no armor to cover legs, no move
10	Knee shattered, no move, -2 penalty to attacks
11	Hip shattered, minor bleeding, no move or attack
12	Leg shattered, no move or attack, major bleeding from compound fractures
13+	As 12 above with tripled damage dice

Location: Abdomen (5)

Severity	Effect
1-3	No unusual effect
4	Victim stunned 1d6 rounds
5	Abdomen struck, victim stunned 1 round and reduced to ½ move
6	Armor damaged, victim stunned 1d6 rounds, triple damage if no armor
7	Abdomen injured, ½ move, -2 penalty to attacks
8	Abdomen injured, minor internal bleeding, ½ move and -2 penalty to attacks
9	Armor damage, abdomen injured, minor bleeding, ½ move and -2 penalty to attacks
10	Abdomen injured, no move or attack, minor internal bleeding
11	Abdomen crushed, no move or attack, major internal bleeding
12	Abdomen crushed, victim reduced to 0 hit points with severe internal bleeding
13+	As 12 above with tripled damage dice

Location: Torso (6-7)

Severity	Effect
1-3	No unusual effect
4	Knockdown, stunned 1d4 rounds
5	Torso struck, victim stunned 1 round and reduced to ½ move
6	Shield damage, torso struck, ½ move
7	Armor damage, torso struck, ½ move, -2 penalty to attacks
8	Torso injured, minor internal bleeding, no move or attack
9	Ribs broken, minor internal bleeding, ½ move, -2 penalty to attacks
10	Ribs broken, major internal bleeding, no move or attack
11	Torso crushed, victim reduced to 0 hit points with severe internal bleeding
12	Torso crushed, victim killed
13+	As 12 above with tripled damage dice

Location: Arms (Left 8, Right 9)

Severity	Effect
1-3	No unusual effect
4	Hand struck, weapon/shield dropped
5	Arm struck, shield damage/weapon dropped
6	Hand broken, -2 penalty to attacks/shield dropped
7	Armor damage, arm broken if victim has no armor to cover limb
8	Shield damage, arm broken, stunned 1 round
9	Weapon dropped, arm broken, stunned 1d4 rounds
10	Shoulder injured, no attacks, minor bleeding
11	Arm shattered, ½ move, no attacks, minor bleeding
12	Shoulder shattered, no move or attacks, major bleeding
13+	As 12 above with tripled damage dice

Location: Head (10)

Severity	Effect
1-3	No unusual effect
4	Victim stunned 1d6 rounds
5	Head struck, helm removed, victim stunned 1 round; -2 penalty to attack rolls if victim had no helm
6	Head struck, -2 penalty to attacks
7	Helm damaged, face injured, stunned 1d6 rounds, ½ move, -4 penalty to attacks
8	Skull broken, helm damaged, victim reduced to 0 hit points and unconscious 1d4 hours
9	Face crushed, minor bleeding, no move or attack, Cha drops by 2 points permanently
10	Head injured, unconscious 1d6 days, lose 1 point each of Int/Wis/Cha permanently
11	Skull crushed, reduced to 0 hit points, major bleeding, Int, Wis, Cha all drop by ½ permanently
12	Skull crushed, immediate death
13+	As 12 above with tripled damage dice

Chapter Six

Bludgeoning vs. Animals

Hit Location Chart

d10 roll	Location
1	Right foreleg/wing
2	Left foreleg/wing
3	Right hind leg
4	Left hind leg
5	Tail (for snakes or fish, 1–5 is tail hit)
6–7	Abdomen
8–9	Torso/chest
10	Head

Location: Legs/Wings (1–4)

Severity	Effect
1–3	No unusual effect
4	Victim knocked down
5	Knee struck, victim reduced to $\frac{1}{2}$ move
6	Foot/wrist broken, $\frac{1}{2}$ move
7	Leg injured, $\frac{1}{2}$ move, –2 penalty to attacks
8	Hip broken, minor bleeding, no movement, –2 penalty to attacks; wing hit forces crash landing
9	Leg broken, $\frac{1}{2}$ move, minor bleeding; wing hit forces immediate landing
10	Knee shattered, $\frac{1}{2}$ move, –2 penalty to attacks
11	Hip/shoulder shattered, minor bleeding, no move or attack; wing hit forces crash landing
12	Leg/wing shattered, no move or attack, major bleeding from compound fractures
13+	As 12 above with tripled damage dice

Location: Tail (5)

Severity	Effect
1–5	No unusual effect
6	Tip of tail struck; if prehensile, any items carried are dropped, –2 penalty to tail attacks due to pain
7–8	Tail injured, normal animals must save vs. death or retreat in pain; lose any tail attacks
9–10	Tail broken, lose any tail attacks, $\frac{1}{2}$ move if animal uses tail for movement
11	Tail crushed, victim stunned 1–3 rounds, lose any tail attacks, no movement or attacks if animal uses tail for movement
12	Tail crushed, pain reduces creature to $\frac{1}{2}$ move and –2 penalty on any attack, minor bleeding; no move or attack if animal uses tail for movement
13+	As 12 above with tripled damage dice

Location: Abdomen (6–7)

Severity	Effect
1–3	No unusual effect
4	Victim stunned 1d6 rounds
5	Abdomen struck, victim stunned 1 round and reduced to $\frac{1}{2}$ move
6	Abdomen struck, victim stunned 1d6 rounds, reduced to $\frac{1}{2}$ move
7	Abdomen injured, $\frac{1}{2}$ move, –2 penalty to attacks
8	Spine broken, no move, –4 penalty to attacks
9	Abdomen injured, minor bleeding, $\frac{1}{2}$ move and –2 penalty to attacks
10	Abdomen injured, no move or attack, minor internal bleeding
11	Spine crushed, no move or attack, major internal bleeding
12	Abdomen crushed, victim reduced to 0 hit points with severe internal bleeding
13+	As 12 above with tripled damage dice

Location: Torso (8–9)

Severity	Effect
1–3	No unusual effect
4	Knockdown, stunned 1d4 rounds
5	Torso struck, victim stunned 1 round and reduced to $\frac{1}{2}$ move
6	Torso struck, stunned 1d6 rounds, $\frac{1}{2}$ move
7	Spine struck, $\frac{1}{2}$ move, –2 penalty to attacks
8	Torso injured, minor internal bleeding, no move or attack
9	Ribs broken, minor internal bleeding, $\frac{1}{2}$ move, –2 penalty to attacks
10	Ribs broken, major internal bleeding, no move or attack
11	Spine crushed, victim reduced to 0 hit points with severe internal bleeding
12	Torso crushed, victim killed
13+	As 12 above with tripled damage dice

Location: Head (10)

Severity	Effect
1–3	No unusual effect
4	Victim stunned 1d6 rounds
5	Snout struck, animal must save vs. death or retreat in pain for 1d10 rounds
6	Head struck, –2 penalty to attacks
7	Jaw injured, stunned 1d6 rounds, $\frac{1}{2}$ move, –4 penalty to all attacks
8	Skull broken, animal reduced to 0 hit points and unconscious 1d4 hours
9	Snout/face crushed, minor bleeding, $\frac{1}{2}$ move, no bite attacks, –4 penalty to all other attacks
10	Head injured, unconscious 2d4 hours, reduced to $\frac{1}{2}$ move and –4 penalty to all attacks for 1d3 months
11	Skull crushed, reduced to 0 hit points, major bleeding, Int, Wis, Cha all drop by $\frac{1}{2}$ permanently
12	Skull crushed, immediate death
13+	As 12 above with tripled damage dice

Critical Hits

Bludgeoning vs. Monsters

Hit Location Chart

d10 Roll	Location
1	Right foreleg/claw/wing
2	Left foreleg/claw/wing
3	Right hind leg
4	Left hind leg
5	Tail (for snakelike or fishlike monsters, 1–5 is tail hit)
6–7	Abdomen
8–9	Torso/chest
10	Head

Location: Legs/Wings (1–4)

Severity	Effect
1–3	No unusual effect
4	Victim knocked down
5	Knee struck, victim reduced to $\frac{2}{3}$ move, –2 penalty to attacks with that appendage
6	Foot/wrist broken, $\frac{2}{3}$ move, –4 penalty to attacks with that appendage
7	Limb injured, $\frac{2}{3}$ move, –2 penalty to all attacks
8	Hip broken, minor bleeding, $\frac{1}{2}$ move, no attacks with limb; wing hit forces crash landing
9	Limb broken, $\frac{2}{3}$ move, minor bleeding; wing hit forces immediate landing
10	Knee shattered, $\frac{1}{2}$ move, –2 penalty to all attacks
11	Hip/shoulder shattered, minor bleeding, $\frac{1}{2}$ move, –4 penalty to all attacks; wing hit forces crash
12	Leg/wing shattered, no move, –4 penalty to all attacks, major bleeding from compound fractures
13+	As 12 above with tripled damage dice

Location: Tail (5)

Severity	Effect
1–5	No unusual effect
6	Tip of tail struck; if prehensile, any items carried are dropped, –2 penalty to tail attacks due to pain
7–8	Tail injured, lose any tail attacks
9–10	Tail broken, lose any tail attacks, if creature uses tail for movement reduced to $\frac{1}{2}$ move
11	Tail crushed, victim stunned 1–3 rounds, lose any tail attacks, no movement if monster uses tail for movement and –4 penalty to all attacks
12	Tail crushed, pain reduces creature to $\frac{1}{2}$ move and –2 penalty on any attack, minor bleeding; if animal uses tail for movement, no move or attack
13+	As 12 above with tripled damage dice

Location: Abdomen (6–7)

Severity	Effect
1–3	No unusual effect
4	Victim stunned 1d4 rounds
5	Abdomen struck, victim stunned 1 round and reduced to $\frac{2}{3}$ move
6	Abdomen struck, victim stunned 1d6 rounds, reduced to $\frac{2}{3}$ move
7	Abdomen injured, $\frac{1}{2}$ move, –2 penalty to attacks
8	Spine injured, $\frac{1}{2}$ move, –4 penalty to attacks
9	Abdomen injured, victim stunned 1d3 rounds, minor bleeding, $\frac{1}{2}$ move and –2 penalty to attacks
10	Abdomen injured, no move or attack, minor internal bleeding
11	Spine crushed, no move or attack, major internal bleeding
12	Abdomen crushed, victim reduced to 0 hit points with severe internal bleeding
13+	As 12 above with tripled damage dice

Location: Torso (8–9)

Severity	Effect
1–3	No unusual effect
4	Knockdown, stunned 1d4 rounds
5	Torso struck, victim stunned 1 round and reduced to $\frac{2}{3}$ move
6	Torso struck, stunned 1d6 rounds, $\frac{2}{3}$ move
7	Spine struck, $\frac{1}{2}$ move, –2 penalty to attacks
8	Torso injured, minor internal bleeding, $\frac{1}{2}$ move, –4 penalty to all attacks
9	Ribs broken, minor internal bleeding, $\frac{1}{2}$ move, –2 penalty to attacks
10	Ribs broken, major internal bleeding, no move or attack
11	Spine crushed, victim reduced to 0 hit points with severe internal bleeding
12	Torso crushed, victim killed
13+	As 12 above with tripled damage dice

Location: Head (10)

Severity	Effect
1–3	No unusual effect
4	Victim stunned 1d4 rounds
5	Jaw struck, –2 penalty to any bite attacks
6	Head struck, stunned 1 round, –2 penalty to attacks
7	Jaw injured, stunned 1d4 rounds, $\frac{2}{3}$ move, no bite attacks
8	Skull broken, monster reduced to $\frac{1}{4}$ normal hit points and unconscious 2d10 turns
9	Snout/face crushed, minor bleeding, $\frac{1}{2}$ move, no bite attacks, –4 penalty to all other attacks
10	Head injured, unconscious 1d10 turns, reduced to $\frac{1}{2}$ move and –4 penalty to all attacks for 3d6 days
11	Skull crushed, reduced to 0 hit points, major bleeding, Int, Wis, Cha all drop by $\frac{1}{2}$ permanently
12	Skull crushed, immediate death
13+	As 12 above with tripled damage dice

Chapter Six

Slashing vs. Humanoids

Hit Location Chart

d10 Roll	Location
1-2	Right leg
3-4	Left leg
5	Abdomen
6-7	Torso
8	Right arm
9	Left arm
10	Head

Location: Legs (Right 1-2, Left 3-4)

Severity	Effect
1-3	No unusual effect
4	Leg struck, minor bleeding
5	Leg struck, minor bleeding; ½ move
6	Leg injured, major bleeding, ½ move
7	Armor damaged; leg injured if target has no leg armor, ½ move, major bleeding
8	Knee shattered, major bleeding, no move, -4 penalty to any attacks
9	Armor damaged, leg struck, minor bleeding, ½ move; if target has no leg armor, leg severed at knee, severe bleeding, no move or attack
10	Hip shattered, no move or attack, severe bleeding
11	Leg severed, severe bleeding, no move or attack
12	Leg severed at thigh, no move or attack, victim reduced to 0 hit points with severe bleeding
13+	As 12 above with tripled damage dice

Location: Abdomen (5)

Severity	Effect
1-3	No unusual effect
4	Abdomen grazed, minor bleeding
5	Abdomen struck, victim stunned 1 round and reduced to ½ move with minor bleeding
6	Armor damaged; victim stunned 1d6 rounds, major bleeding, ½ move if no armor
7	Abdomen injured, major bleeding, ½ move, -2 penalty to attacks
8	Abdomen injured, severe bleeding, ½ move, -4 penalty to attacks
9	Armor damage, abdomen injured, minor bleeding, ½ move and -2 penalty to attacks; if no armor, victim at 0 hit points, major bleeding
10	Abdomen injured, no move or attack, severe bleeding
11	Abdomen injured, victim at 0 hp, severe bleeding
12	Abdomen destroyed, victim killed
13+	As 12 above with tripled damage dice

Location: Torso (6-7)

Severity	Effect
1-3	No unusual effect
4	Torso grazed, minor bleeding
5	Torso struck, victim stunned 1 round, reduced to ½ move with minor bleeding
6	Shield damage, torso struck, ½ move & minor bleeding
7	Armor damage, torso struck, ½ move, -2 penalty to attacks; if no armor, torso injured, no move or attack, severe bleeding
8	Torso injured, major bleeding, ½ move, -4 penalty to attacks
9	Shield damage; torso struck, -2 penalty to attacks; if no shield, torso injured, severe bleeding, no move or attack
10	Torso injured, severe bleeding, no move or attack
11	Torso destroyed, victim reduced to 0 hit points with severe bleeding
12	Torso destroyed, victim killed
13+	As 12 above with tripled damage dice

Location: Arms (Left 8, Right 9)

Severity	Effect
1-3	No unusual effect
4	Hand struck, weapon dropped, minor bleeding; no effect on shield arm
5	Arm struck, shield damage/weapon dropped, minor bleeding
6	Hand injured, -2 penalty to attacks/shield dropped
7	Armor damage, arm struck, minor bleeding; if no armor, arm injured, major bleeding
8	Hand severed, stunned 1 round, major bleeding, shield or weapon dropped
9	Armor damage, arm broken; if no armor, arm severed, stunned 1d6 rounds, major bleeding
10	Shoulder injured, no attacks, major bleeding
11	Arm severed, severe bleeding, ½ move
12	Arm severed, no move or attacks, severe bleeding
13+	As 12 above with tripled damage dice

Location: Head (10)

Severity	Effect
1-3	No unusual effect
4	Head grazed, stunned 1d3 rounds, minor bleeding
5	Head struck, helm removed, victim stunned 1 round; -2 penalty to attack rolls, minor bleeding if victim had no helm
6	Head struck, minor bleeding, victim blinded for 2d4 rounds by blood in eyes
7	Helm damaged, face injured, stunned 1d6 rounds, minor bleeding, ½ move, -4 penalty to attacks
8	Skull broken, helm damaged, victim reduced to 0 hit points, major bleeding
9	Throat injured, severe bleeding
10	Skull destroyed, victim reduced to 0 hp, severe bleeding, Int, Wis, Cha all drop by ½ permanently
11	Throat destroyed, victim killed
12	Head severed, immediate death
13+	As 12 above with tripled damage dice

Critical Hits



Slashing vs. Animals

Hit Location Chart

d10 Roll	Location
1	Right foreleg/wing
2	Left foreleg/wing
3	Right hind leg
4	Left hind leg
5	Tail (for snakes or fish, 1–5 is tail hit)
6–7	Abdomen
8–9	Torso/chest
10	Head

Location: Legs/Wings (1–4)

Severity	Effect
1–3	No unusual effect
4	Leg struck, minor bleeding
5	Knee struck, $\frac{2}{3}$ move, minor bleeding
6	Leg injured, major bleeding, $\frac{2}{3}$ move
7	Foot/claw injured, $\frac{2}{3}$ move, minor bleeding, –2 penalty to attacks with that limb
8	Hip injured, major bleeding, $\frac{1}{2}$ movement, –2 penalty to attacks; wing hit forces crash landing
9	Leg/wing severed at midpoint, $\frac{1}{2}$ move, major bleeding; wing hit forces uncontrolled fall
10	Knee destroyed, major bleeding, $\frac{1}{2}$ move, –2 penalty to all attacks
11	Hip/shoulder destroyed, severe bleeding, no move or attack; wing hit forces crash landing
12	Leg/wing severed at mid-thigh, no move or attack, severe bleeding
13+	As 12 above with tripled damage dice

Location: Tail (5)

Severity	Effect
1–5	No unusual effect
6	Tip of tail struck; if prehensile, any items carried are dropped, minor bleeding, –2 penalty to tail attacks
7–8	Tail injured, minor bleeding, normal animals must save vs. death or retreat; no tail attacks
9–10	Tail severed near end, major bleeding, lose tail attacks; move reduced by $\frac{1}{2}$ if creature uses tail for movement
11	Tail severed, victim stunned 1–3 rounds, lose tail attacks, major bleeding, no movement or attacks if animal uses tail for movement
12	Tail severed, stunned 1–3 rounds, major bleeding, $\frac{1}{2}$ move and –2 penalty on any attack; if animal uses tail for movement, no move or attack
13+	As 12 above with tripled damage dice

Location: Abdomen (6–7)

Severity	Effect
1–3	No unusual effect
4	Abdomen grazed, minor bleeding
5	Abdomen struck, victim stunned 1 round and reduced to $\frac{2}{3}$ move, minor bleeding
6	Abdomen struck, victim stunned 1d6 rounds, reduced to $\frac{2}{3}$ move, minor bleeding
7	Abdomen injured, $\frac{1}{2}$ move, minor bleeding, –2 penalty to all attacks
8	Spine injured, no move, minor bleeding, –4 penalty to attacks
9	Abdomen injured, major bleeding, $\frac{1}{2}$ move and –2 penalty to attacks
10	Abdomen injured, no move or attack, major bleeding
11	Spine destroyed, no move or attack, major bleeding, victim paralyzed
12	Abdomen destroyed, victim reduced to 0 hit points with severe bleeding
13+	As 12 above with tripled damage dice

Location: Torso (8–9)

Severity	Effect
1–3	No unusual effect
4	Torso grazed, minor bleeding
5	Torso struck, victim stunned 1 round and reduced to $\frac{2}{3}$ move, minor bleeding
6	Torso struck, stunned 1d6 rounds, minor bleeding
7	Spine struck, major bleeding, $\frac{2}{3}$ move, –2 penalty to attacks
8	Torso injured, severe bleeding, no move or attack
9	Ribs broken, major bleeding, $\frac{1}{2}$ move, –4 penalty to attacks
10	Ribs broken, severe bleeding, no move or attack
11	Spine destroyed, victim reduced to 0 hit points with severe bleeding
12	Torso destroyed, victim killed
13+	As 12 above with tripled damage dice

Location: Head (10)

Severity	Effect
1–3	No unusual effect
4	Head grazed, stunned 1 round, minor bleeding
5	Snout struck, minor bleeding, animal must save vs. death or retreat for 1d10 rounds
6	Head struck, minor bleeding, –2 penalty to attacks
7	Throat injured, major bleeding, $\frac{2}{3}$ move, –4 penalty to all attacks
8	Skull broken, animal reduced to 0 hit points, major bleeding
9	Snout/face destroyed, major bleeding, $\frac{1}{2}$ move, no bite attacks, –4 penalty to all other attacks
10	Head injured, reduced to 0 hp, severe bleeding; $\frac{1}{2}$ move and –4 penalty to all attacks for 1d3 months
11	Throat destroyed, severe bleeding
12	Head severed, immediate death
13+	As 12 above with tripled damage dice

Chapter Six

Slashing vs. Monsters

Hit Location Chart

d10 Roll	Location
1	Right foreleg/claw/wing
2	Left foreleg/claw/wing
3	Right hind leg
4	Left hind leg
5	Tail (for snakelike or fishlike monsters, 1–5 is tail hit)
6–7	Abdomen
8–9	Torso/chest
10	Head

Location: Legs/Wings (1–4)

Severity	Effect
1–3	No unusual effect
4	Leg grazed, minor bleeding
5	Knee struck, $\frac{2}{3}$ move, minor bleeding
6	Leg struck, minor bleeding, $\frac{2}{3}$ move
7	Foot/claw injured, $\frac{2}{3}$ move, minor bleeding, –2 penalty to attacks with that limb
8	Hip injured, major bleeding, $\frac{1}{3}$ movement; wing hit forces crash landing
9	Leg/wing severed at midpoint, $\frac{1}{3}$ move, major bleeding; wing hit forces uncontrolled fall
10	Knee destroyed, major bleeding, $\frac{1}{3}$ move, –2 penalty to attacks with affected limb
11	Hip/shoulder destroyed, major bleeding, no move, –4 penalty to attacks; wing hit forces crash landing
12	Leg/wing severed at mid-thigh, no move or attack, severe bleeding
13+	As 12 above with tripled damage dice

Location: Tail (5)

Severity	Effect
1–5	No unusual effect
6	Tip of tail struck; if prehensile, any items carried are dropped, minor bleeding, –2 penalty to tail attacks
7–8	Tail injured, minor bleeding, monster suffers –2 penalty to all attacks due to pain; no tail attacks
9–10	Tail severed, major bleeding, no tail attacks; if creature uses tail for movement, $\frac{1}{3}$ move
11	Tail severed, victim stunned 1 round, lose tail attacks, major bleeding; $\frac{1}{3}$ movement, –4 penalty to attacks if monster uses tail for movement
12	Tail severed, stunned 1 round, major bleeding, $\frac{1}{3}$ move and –2 penalty on any attack; if animal uses tail for movement, no move or attack
13+	As 12 above with tripled damage dice

Location: Abdomen (6–7)

Severity	Effect
1–3	No unusual effect
4	Abdomen grazed, minor bleeding
5	Abdomen struck, victim stunned 1 round, minor bleeding
6	Abdomen struck, victim stunned 1d3 rounds, reduced to $\frac{2}{3}$ move, minor bleeding
7	Abdomen injured, $\frac{1}{3}$ move, minor bleeding, –2 penalty to all attacks
8	Spine injured, $\frac{1}{3}$ move, minor bleeding, –4 penalty to all attacks
9	Abdomen injured, major bleeding, $\frac{1}{3}$ move and –2 penalty to attacks
10	Abdomen injured, $\frac{1}{3}$ move, –4 penalty to attacks, major bleeding
11	Spine injured, no move or attack, major bleeding, victim stunned 1d6 rounds
12	Abdomen destroyed, victim reduced to 0 hit points with severe bleeding
13+	As 12 above with tripled damage dice

Location: Torso (8–9)

Severity	Effect
1–3	No unusual effect
4	Torso grazed, minor bleeding
5	Torso struck, victim stunned 1 round, minor bleeding
6	Torso struck, stunned 1d3 rounds, minor bleeding
7	Spine struck, minor bleeding, $\frac{2}{3}$ move, –2 penalty to attacks
8	Torso injured, major bleeding, $\frac{1}{3}$ move, –4 penalty to attacks
9	Ribs injured, major bleeding, $\frac{1}{3}$ move, –4 penalty to attacks
10	Ribs broken, severe bleeding, $\frac{1}{3}$ move, no attack
11	Spine broken, major bleeding, no move or attack
12	Torso destroyed, victim killed
13+	As 12 above with tripled damage dice

Location: Head (10)

Severity	Effect
1–3	No unusual effect
4	Head grazed, minor bleeding
5	Snout struck, minor bleeding, monster must save vs. death or retreat for 1 round
6	Head struck, minor bleeding, –2 penalty to attacks
7	Throat injured, major bleeding, $\frac{2}{3}$ move, –2 penalty to all attacks
8	Skull injured, monster reduced to $\frac{2}{3}$ move, major bleeding, –2 penalty to all attacks
9	Snout/face injured, major bleeding, $\frac{1}{3}$ move, no bite attacks, –2 penalty to all other attacks
10	Head injured, reduced to 0 hp, major bleeding; $\frac{1}{3}$ move and –4 penalty to all attacks for 1d3 weeks
11	Throat destroyed, severe bleeding
12	Head severed, immediate death
13+	As 12 above with tripled damage dice

Critical Hits

Piercing vs. Humanoids

Hit Location Chart

d10 Roll	Location
1-2	Right leg
3-4	Left leg
5	Abdomen
6-7	Torso
8	Right arm
9	Left arm
10	Head

Location: Legs (Right 1-2, Left 3-4)

Severity	Effect
1-3	No unusual effect
4	Leg grazed, victim knocked down
5	Leg struck, minor bleeding
6	Leg injured, minor bleeding, $\frac{2}{3}$ move
7	Armor damaged; leg injured if target has no leg armor, $\frac{1}{2}$ move, major bleeding
8	Knee broken, minor bleeding, $\frac{1}{2}$ move, -4 penalty to any attacks
9	Armor damaged, leg struck, minor bleeding, $\frac{2}{3}$ move; if target has no leg armor, leg broken, major bleeding, $\frac{1}{2}$ move, -4 penalty to attacks
10	Hip broken, no move or attack, major bleeding
11	Leg broken, severe bleeding, no move or attack
12	Leg destroyed, no move or attack, severe bleeding
13+	As 12 above with tripled damage dice

Location: Abdomen (5)

Severity	Effect
1-3	No unusual effect
4	Abdomen grazed, minor bleeding
5	Abdomen struck, victim stunned 1 round and reduced to $\frac{2}{3}$ move with minor bleeding
6	Armor damaged; victim stunned 1d4 rounds, minor bleeding, $\frac{2}{3}$ move if no armor
7	Abdomen injured, major bleeding, $\frac{1}{2}$ move, -2 penalty to attacks
8	Abdomen injured, severe bleeding, $\frac{1}{2}$ move, -4 penalty to attacks
9	Armor damage, abdomen injured, minor bleeding, $\frac{1}{2}$ move and -2 penalty to attacks; if no armor, victim at 0 hit points, major bleeding
10	Abdomen injured, $\frac{1}{2}$ move, no attack, severe bleeding
11	Abdomen injured, victim at 0 hp, severe bleeding
12	Abdomen destroyed, victim killed
13+	As 12 above with tripled damage dice

Location: Torso (6-7)

Severity	Effect
1-3	No unusual effect
4	Torso grazed, minor bleeding
5	Torso struck, $\frac{2}{3}$ move with minor bleeding
6	Shield damage, torso struck, $\frac{2}{3}$ move & minor bleeding
7	Armor damage, torso struck, $\frac{2}{3}$ move, -2 penalty to attacks; if no armor, torso injured, no move or attack, severe bleeding
8	Torso injured, major bleeding, $\frac{1}{2}$ move, -4 penalty to attacks
9	Shield damage; torso struck, -2 penalty to attacks; if no shield, ribs broken, severe bleeding, no move or attack
10	Ribs broken, severe bleeding, no move or attack
11	Torso destroyed, victim reduced to 0 hit points with severe bleeding
12	Torso destroyed, victim killed
13+	As 12 above with tripled damage dice

Location: Arms (Left 8, Right 9)

Severity	Effect
1-3	No unusual effect
4	Hand struck, weapon dropped, minor bleeding; no effect on shield arm
5	Arm struck, shield damage/weapon dropped, minor bleeding
6	Hand injured, -2 penalty to attacks/shield dropped
7	Armor damage, arm struck, minor bleeding; if no armor, arm injured, minor bleeding
8	Arm broken, victim stunned 1 round, minor bleeding, shield or weapon dropped
9	Armor damage, arm injured, -2 penalty to attacks or shield dropped; if no armor, arm broken, stunned 1d6 rounds, major bleeding
10	Shoulder injured, no attacks, major bleeding
11	Arm destroyed, major bleeding, $\frac{2}{3}$ move
12	Arm destroyed, no move/attack, major bleeding
13+	As 12 above with tripled damage dice

Location: Head (10)

Severity	Effect
1-3	No unusual effect
4	Head grazed, stunned 1d3 rounds, minor bleeding
5	Head struck, helm removed, victim stunned 1 round; -2 penalty to attack rolls, minor bleeding if victim had no helm
6	Eye injured, -4 penalty to all attacks; if helmed, victim is only stunned 1 round instead
7	Helm damaged, face injured, stunned 1d6 rounds, minor bleeding, $\frac{2}{3}$ move, -4 penalty to attacks
8	Skull broken, helm damaged, victim reduced to 0 hit points, major bleeding
9	Throat injured, severe bleeding
10	Skull broken, victim reduced to 0 hp, major bleeding, Int, Wis, Cha all drop by $\frac{1}{2}$ permanently
11	Throat destroyed, victim killed
12	Head destroyed, immediate death
13+	As 12 above with tripled damage dice

Chapter Six

Piercing vs. Animals

Hit Location Chart

d10 Roll	Location
1	Right foreleg/wing
2	Left foreleg/wing
3	Right hind leg
4	Left hind leg
5	Tail (for snakes or fish, 1-5 is tail hit)
6-7	Abdomen
8-9	Torso/chest
10	Head

Location: Legs/Wings (1-4)

Severity	Effect
1-3	No unusual effect
4	Leg struck, minor bleeding
5	Knee struck, $\frac{2}{3}$ move, minor bleeding
6	Leg injured, minor bleeding, $\frac{2}{3}$ move
7	Foot/daw injured, minor bleeding, -2 penalty to attacks with that limb
8	Hip injured, minor bleeding, $\frac{2}{3}$ movement, -2 penalty to all attacks; wing hit forces crash landing
9	Leg/wing broken, $\frac{1}{2}$ move, minor bleeding; wing hit forces crash landing
10	Knee broken, minor bleeding, $\frac{1}{2}$ move, -2 penalty to all attacks
11	Hip/shoulder destroyed, major bleeding, no move or attack; wing hit forces crash landing
12	Leg/wing destroyed, no move or attack, major bleeding
13+	As 12 above with tripled damage dice

Location: Tail (5)

Severity	Effect
1-5	No unusual effect
6	Tip of tail struck; if prehensile, any items carried are dropped, minor bleeding, -2 penalty to tail attacks
7-8	Tail injured, minor bleeding, normal animals must save vs. death or retreat; no tail attacks
9-10	Tail injured, minor bleeding, lose tail attacks; if creature uses tail for movement, $\frac{1}{2}$ move
11	Tail destroyed, victim stunned 1-3 rounds, lose tail attacks, major bleeding, no movement or attacks if animal uses tail for movement
12	Tail destroyed, stunned 1d2 rounds, major bleeding, $\frac{1}{2}$ move and -2 penalty on attacks; if animal uses tail for movement, no move or attack
13+	As 12 above with tripled damage dice

Location: Abdomen (6-7)

Severity	Effect
1-3	No unusual effect
4	Abdomen grazed, minor bleeding
5	Abdomen struck, victim stunned 1 round and reduced to $\frac{2}{3}$ move, minor bleeding
6	Abdomen struck, victim stunned 1d4 rounds, reduced to $\frac{2}{3}$ move, minor bleeding
7	Abdomen injured, $\frac{2}{3}$ move, major bleeding, -2 penalty to all attacks
8	Spine injured, $\frac{1}{2}$ move, minor bleeding, -4 penalty to all attacks
9	Abdomen injured, major bleeding, $\frac{1}{2}$ move and -2 penalty to all attacks
10	Abdomen injured, no move or attack, major bleeding
11	Spine broken, no move or attack, major bleeding, victim paralyzed
12	Abdomen destroyed, victim reduced to 0 hit points with severe bleeding
13+	As 12 above with tripled damage dice

Location: Torso (8-9)

Severity	Effect
1-3	No unusual effect
4	Torso grazed, minor bleeding
5	Torso struck, victim stunned 1 round and reduced to $\frac{2}{3}$ move, minor bleeding
6	Torso struck, stunned 1d4 rounds, minor bleeding
7	Spine struck, minor bleeding, $\frac{2}{3}$ move, -2 penalty to attacks
8	Torso injured, stunned 1 round, major bleeding
9	Ribs broken, minor bleeding, $\frac{1}{2}$ move, -4 penalty to attacks
10	Ribs broken, major bleeding, no move or attack
11	Spine destroyed, victim reduced to 0 hit points with major bleeding
12	Torso destroyed, victim killed
13+	As 12 above with tripled damage dice

Location: Head (10)

Severity	Effect
1-3	No unusual effect
4	Head grazed, stunned 1 round, minor bleeding
5	Snout struck, minor bleeding, animal must save vs. death or retreat for 1d10 rounds
6	Eye injured, stunned 1d3 rounds, -2 penalty to attacks
7	Throat injured, major bleeding, $\frac{2}{3}$ move, -4 penalty to all attacks
8	Skull broken, animal reduced to 0 hit points, major bleeding
9	Snout/face destroyed, minor bleeding, $\frac{1}{2}$ move, no bite attacks, -4 penalty to all other attacks
10	Head injured, reduced to 0 hp, major bleeding; $\frac{1}{2}$ move and -4 penalty to all attacks for 1d3 months
11	Throat destroyed, severe bleeding
12	Head severed, immediate death
13+	As 12 above with tripled damage dice

Critical Hits



Piercing vs. Monsters

Hit Location Chart

d10 Roll	Location
1	Right foreleg/claw/wing
2	Left foreleg/claw/wing
3	Right hind leg
4	Left hind leg
5	Tail (for snakelike or fishlike monsters, 1-5 is tail hit)
6-7	Abdomen
8-9	Torso/chest
10	Head

Location: Legs/Wings (1-4)

Severity	Effect
1-3	No unusual effect
4	Leg grazed, minor bleeding
5	Knee struck, $\frac{2}{3}$ move
6	Leg struck, minor bleeding, $\frac{2}{3}$ move
7	Foot/claw injured, minor bleeding, -2 penalty to attacks with that limb
8	Hip injured, minor bleeding, $\frac{1}{2}$ movement; wing hit forces crash landing
9	Leg/wing broken, $\frac{1}{2}$ move, minor bleeding; wing hit forces crash landing
10	Knee destroyed, major bleeding, $\frac{1}{2}$ move, -2 penalty to attacks with affected limb
11	Hip/shoulder destroyed, major bleeding, no move, -4 penalty to attacks; wing hit forces crash landing
12	Leg/wing destroyed, no move or attack, major bleeding
13+	As 12 above with tripled damage dice

Location: Tail (5)

Severity	Effect
1-5	No unusual effect
6	Tip of tail struck; if prehensile, any items carried are dropped, minor bleeding, -2 penalty to tail attacks
7-8	Tail injured, minor bleeding, monster suffers -2 penalty to all attacks due to pain; no tail attacks
9-10	Tail broken, minor bleeding, no tail attacks; if creature uses tail for movement, $\frac{1}{2}$ move
11	Tail destroyed, victim stunned 1 round, lose tail attacks, major bleeding; $\frac{1}{2}$ movement, -4 penalty to attacks if monster uses tail for movement
12	Tail destroyed, stunned 1d3 rounds, major bleeding, $\frac{1}{2}$ move and -2 penalty on any attack; if monster uses tail for movement, no move/attack
13+	As 12 above with tripled damage dice

Location: Abdomen (6-7)

Severity	Effect
1-3	No unusual effect
4	Abdomen grazed, minor bleeding
5	Abdomen struck, victim stunned 1 round, minor bleeding
6	Abdomen struck, victim stunned 1d3 rounds, minor bleeding
7	Abdomen injured, $\frac{2}{3}$ move, minor bleeding, -2 penalty to all attacks
8	Spine injured, $\frac{1}{2}$ move, minor bleeding, -4 penalty to all attacks
9	Abdomen injured, major bleeding, $\frac{1}{2}$ move and -2 penalty to attacks
10	Abdomen injured, $\frac{1}{2}$ move, -4 penalty to attacks, major bleeding
11	Spine injured, no move or attack, major bleeding, victim stunned 1d6 rounds
12	Abdomen destroyed, victim reduced to 0 hit points with major bleeding
13+	As 12 above with tripled damage dice

Location: Torso (8-9)

Severity	Effect
1-3	No unusual effect
4	Torso grazed, minor bleeding
5	Torso struck, victim stunned 1 round, minor bleeding
6	Torso struck, stunned 1d3 rounds, minor bleeding
7	Spine struck, minor bleeding, $\frac{2}{3}$ move, -2 penalty to attacks
8	Torso injured, minor bleeding, $\frac{1}{2}$ move, -4 penalty to attacks
9	Ribs injured, major bleeding, $\frac{1}{2}$ move, -4 penalty to attacks
10	Ribs broken, major bleeding, $\frac{1}{2}$ move, no attack
11	Spine broken, major bleeding, no move or attack
12	Torso destroyed, victim killed
13+	As 12 above with tripled damage dice

Location: Head (10)

Severity	Effect
1-3	No unusual effect
4	Head grazed, minor bleeding
5	Snout struck, minor bleeding, monster must save vs. death or retreat for 1 round
6	Eye injured, stunned 1 round, -2 penalty to attacks
7	Throat injured, major bleeding, $\frac{2}{3}$ move, -2 penalty to all attacks
8	Skull injured, monster reduced to $\frac{2}{3}$ move, major bleeding, -2 penalty to all attacks
9	Snout/face injured, major bleeding, $\frac{1}{2}$ move, no bite attacks, -2 penalty to all other attacks
10	Head injured, reduced to 0 hp, major bleeding; $\frac{1}{2}$ move and -4 penalty to all attacks for 1d3 weeks
11	Throat destroyed, severe bleeding
12	Head destroyed, immediate death
13+	As 12 above with tripled damage dice

Chapter Seven: Weapons & Armor



Characters are defined not only by their abilities and alignment, but also by their possessions and equipment. With the proper preparation and gear, there's almost nothing a daring hero can't accomplish.

This chapter presents a comprehensive listing of just about any kind of weapon or armor a character would ever want to use. The list is divided into nine different semi-historical groupings to help preserve consistency and accuracy. For example, the most sophisticated armor available during Western Europe's Dark Ages was chain mail; plate mail hadn't been invented yet. If a particular nation or culture in your campaign has a Dark Ages flavor to it, armor heavier than chain mail shouldn't be available there.

The equipment categories are Stone Age, Bronze Age, Roman, Dark Ages, Crusades, Renaissance, English Civil War, Middle Eastern, and Oriental.

The second purpose of this chapter is to update weapon and armor statistics for the PLAYER'S OPTION combat system. In addition to the standard size, type, and damage listings, a new number has been introduced: the knockdown die. Speed factors are printed as both a number and a category, for use in a standard AD&D game or with the PLAYER'S OPTION initiative rules. Partial armor tables are included, so that players can re-create historical or fantastic styles such as back-and-breast plate with greaves, chain-mail shirts, and so on.

Last but not least, a complete explanation of special weapon properties and encumbrance is included at the end of this chapter.

Weapons & Armor

Equipment Groups

As long as people have been making weapons, different cultures have produced different types of armaments. One wouldn't expect

to find an English longbow in ancient Greece, or a samurai's katana in medieval Venice. Of course, many AD&D campaigns aren't very "realistic," but even in the most cosmopolitan settings there will be local standards of technology and preferred weapons and equipment.

It's always possible for rare or unusual weapons to trickle into an area from outside. For example, if a tribe of jungle savages has been trading with a more advanced culture, it's quite likely that they may have learned metalworking or at least be armed with steel spearheads and arrowheads they traded for. Despite this, players should try to equip their characters in a reasonable and consistent fashion. A Viking-like barbarian from the far north has no business beginning a campaign equipped with a blowgun, katana, or scimitar. It's far more reasonable for the character to wear chain mail and carry a throwing axe and long sword. The DM is the final judge of what a character can reasonably expect to be able to find in any particular area.

Reading the Equipment Lists

The culture lists include the following information:

Name: Most weapons have been described by their common AD&D equivalent, so a *flamberge* or *zweihander* is simply referred to as a two-handed sword. There are some exceptions—for example, the gladius, which is just a short sword. The individual weapon descriptions that follow the tables make note of any additional names by which the weapon is known.

Cost: Each weapon has a listed cost based on the standard AD&D monetary system. Many weapons have different costs on different tables; these are weapons that are rarer in the one setting than the other. If the weapon has a "—" for cost, it is effectively free, since it can easily be made by any character.

Stone Age or Savage Cultures

Stone Age cultures are rare in most AD&D campaigns. Only the most isolated areas can be considered to be in the Stone Age. In our own history, most Stone Age cultures disappeared thousands of years ago—but those that did survive still live today, in the remote areas of Malaysia and South America.

Stone Age and Savage Settings

Adze	3 gp
Axe	
<i>Battle</i>	15 gp
<i>Hand/throwing</i>	6 gp
Stone	5 sp
Blowgun	1 gp
Barbed dart	1 sp
Needle	2 cp
Bolas	5 sp
Boomerang	5 sp
Bow	
Short	15 gp
<i>flight arrow</i>	3 sp/12
stone arrow	3 cp/12
Club	—
War	2 gp
Dagger	2 gp
Bone	1 sp
Stone	2 sp
Dart	5 sp
Harpoon	20 gp
Bone	1 gp
Javelin	5 sp
Stone	5 cp
Knife	5 sp
Bone	3 cp
Stone	5 cp
<i>Throwing</i>	5 gp
Lasso	5 sp
Parang or Machete	8 gp
Quarterstaff	—
Rock	—
Sling	5 cp
Stone	—
Spear	2 gp
Stone	2 sp

Italic entries are only available in metal-using Stone Age or savage settings.

Just because a culture uses Stone Age technology doesn't mean that it is primitive or barbaric. Native Americans enjoyed complex, advanced societies without metal tools or weapons. Therefore, this category can also be used to describe Aztec-like civilizations that exist as contemporaries of societies with more advanced technology.

Savage settings are found in physically remote areas where primitive societies have gained access to metalworking technology. This is a good catch-all category for equipping barbaric jungle tribes, fierce nomads, or tribes of cannibals. Historically, many African, Asian, and Malaysian nations were considered "savages" by Western European explorers as late as the early part of this

Chapter Seven

century. These unique cultures suffered terribly at the hands of their supposedly more-civilized visitors.

Stone Age weapons include a variety of missiles developed from basic hunting tools. They tend to be inferior to even Bronze Age arms, which were designed as implements of war. Armor is light or nonexistent and consists of a hide-covered shield and leather, hide, or cord body armor at best.

Savage arms include improved metal-headed versions of many Stone Age weapons. Savage armor is also light, but includes copper or bronze reinforcement. In some cases, very sophisticated lamellar or scale armor of wood, bone, or leather may be available. Historically, chain mail appeared in the 18th and 19th century among Malaysian and Asian tribes, hundreds of years after Europeans abandoned its use.

Tools and Common Materials

Adze	3 sp
Belaying pin	2 cp
Bottle	—
Club	—
Great	2 gp
Flail	—
Grain	5 sp
Fork	8 sp
Gaff/hook	—
Attached	2 gp
Held	5 cp
Grapple	5 gp
Hatchet	2 gp
Hammer	5 sp
Harpoon	20 gp
Holy symbol, big	25 gp
Knife	5 sp
Lantern	varies
Lasso	5 sp
Machete	8 gp
Oil flask	6 cp
Pick	4 gp
Pry bar	2 gp
Quarterstaff	—
Sap	5 sp
Scourge	2 gp
Scythe	3 gp
Sickle	6 sp
Sledge hammer	2 gp
Sling	5 cp
Bullet	5 cp
Stone	—
Spade	1 gp
Torch	1 cp
Vial	8 sp
Whip	1 sp

Tools/Common

This list includes anything that is commonly available as a tool or so universal that any culture would have access to it. Picks, spades, and sledge hammers can be found in any town and can make serviceable weapons if swords and bows aren't available. Regardless of the actual setting used, anything on this table can be wielded as a weapon by a character. Note that Stone Age or Savage cultures are not assumed to have access to these implements, which is why the Tools/Common list follows the Stone Age list.

The DM is free to rule that any particular tool or device is unavailable for selection as a weapon proficiency. Most people don't plan on wielding lanterns or spades as weapons on a regular basis.

The Bronze Age and Ancient Cultures

The first metal weapons were made from copper. It was easy to mine and easy to work, but proved to be very soft. By adding tin to copper, a much stronger alloy known as bronze was created. The early civilizations of Egypt and Mesopotamia were manufacturing bronze weapons more than 4,000 years ago.

Unlike Stone Age or savage cultures, Bronze Age cultures are almost never found as contemporaries of more advanced civilizations. Once a nation or tribe masters the working of iron, bronze rapidly falls out of favor. This category is good for campaigns set in ancient times, or for equipping warriors who are somehow displaced in time.

At the beginning of this era, a battle consisted of two mobs of armed men meeting in a brutal melee. By the end of the Bronze Age, sophisticated phalanxes of spearmen and a firm grasp of tactics enabled the Greek city-states to dominate the ancient world. The chariot ruled the battlefield for a while, only to be replaced by more maneuverable cavalry.

Spears, bows, and slings are the most common weapons of this time period. Axes and swords are rarer. Swords evolved from primitive, sickle-shaped chopping weapons into the Greek *xiphos*, a well-made short sword used for thrusting and slashing.

Armor runs the gamut from none at all to sturdy coats of metal lamellar or scales and bronze breastplates and greaves. The armor type known as bronze plate mail has no real historical model, but is included as a logical extension of bronze plates worn over more of the body.

Weapons & Armor



Bronze Age, Ancient Cultures

Adze	3 sp
Battle axe	5 gp
Bow	
Arrow, flight	3 sp/12
Composite short bow	75 gp
Long bow	75 gp
Short bow	30 gp
Cestus	1 gp
Dagger	2 gp
Dart	5 sp
Hand/throwing axe	1 gp
Javelin	5 sp
Lance, light	6 gp
Mace, footman's	8 gp
Mace, horseman's	5 gp
Mace-axe	12 gp
Pike	5 gp
Quarterstaff	—
Spear	8 sp
One-handed	—
Two-handed	—
Spear, long	5 gp
Staff sling	2 sp
Stinkpot	1 sp
Stone	—
Sword	
Broadsword	30 gp
Khopesh	15 gp
Sapara	10 gp
Short	15 gp
Sword-axe	20 gp
Trident	15 gp
Two-handed axe	15 gp
Warhammer	2 gp
War club	2 gp

During this period, iron weapons began to appear. If an iron weapon is used against armor made of bronze, horn, wood, or any weaker material, the attacker gains a +1 bonus to hit. Similarly, if a bronze weapon is used against iron armor, the attacker suffers a -1 penalty to hit. Bronze-on-bronze or iron-on-iron match-ups provide no special bonuses or penalties.

Iron weapons and armor may be considered to be *nonexistent*, *rare*, or *common* in this setting. If the DM decides they're nonexistent, no character can obtain them. If iron is *rare*, any weapon or armor made of iron can be purchased for triple the listed cost. If iron is *common*, iron arms can be purchased at the listed cost. Of course, if iron is common, just about everyone else will have it, too.

Roman

The military system of Rome conquered half the known world. At its height, the Roman Empire stretched from Spain to Palestine and England to Egypt. Roman legionaries were equipped with a cuirass and helmet of iron, a large curved shield, a type of javelin called a *pilum*, and a *gladius*, or short sword. They fought in disciplined, spaced ranks that permitted men in the rear to step forward and relieve tired men in the front line, keeping fresh men in contact with the enemy.

Later in the Roman Empire, cavalry became more and more important. In time, it replaced the infantry legions as the primary weapon of the empire. The emphasis on cavalry led to the development of longer swords and the use of heavier lances in shock charges.

Rome's civilized enemies were equipped in much the same way as her own legions. However, the empire was also confronted with barbaric Gauls, Celts, and Germans. Their warriors often fought with no armor

Roman Cultures

Battle axe	5 gp
Bow	
Arrow, flight	3 sp/12
Composite short bow	75 gp
Long bow	75 gp
Short bow	30 gp
Cestus	1 gp
Dagger	2 gp
Dart	5 sp
Hand/throwing axe	1 gp
Javelin	5 sp
Lance	
Light	6 gp
Medium	10 gp
Mace, footman's	8 gp
Mace, horseman's	5 gp
Net	5 gp
Pilum	1 gp
Quarterstaff	—
Spear	8 sp
Spear, long	5 gp
Staff sling	2 sp
Stinkpot	1 sp
Stone	—
Sword	
Broadsword	15 gp
Drusus	50 gp
Gladius	10 gp
Spatha	25 gp
Trident	15 gp
Warhammer	2 gp

Chapter Seven

and only a spear and shield. It wasn't until the decline of the empire that the legions could be defeated by their ill-equipped foes.

Dark Ages

The Dark Ages are usually considered to extend from the end of the Western Roman Empire to the Norman invasion of England. While Western Europe was in turmoil, the neighboring areas were in far better shape. The Eastern Roman Empire, or Byzantium, survived and grew strong, retaining control of modern-day Turkey and Greece. Islam spread throughout the Levant and northern Africa, bringing enlightenment and civilization.

This grouping of equipment represents a barbarian or backwater kingdom in a fantasy campaign. Since no armor heavier than chain mail exists, many of the

The Dark Ages

Battle axe	5 gp
Bow	
Arrow, flight	3 sp/12
Arrow, sheaf	3 sp/6
Composite short bow	75 gp
Long	75 gp
Short	30 gp
Caltrop	2 gp/12
Crossbow	
Light crossbow	60 gp
Light quarrel	1 sp
Pellet bow	25 gp
Pellet	5 cp
Dagger	2 gp
Dart	5 sp
Hand/throwing axe	1 gp
Javelin	5 sp
Lance	
Light	6 gp
Medium	10 gp
Mace, footman's	8 gp
Mace, horseman's	5 gp
Quarterstaff	—
Spear	8 sp
Spear, long	5 gp
Staff sling	2 sp
Stinkpot	1 sp
Stone	—
Sword	
Broadsword	20 gp
Long sword	45 gp
Sabre	30 gp
Short sword	15 gp
Two-handed axe	15 gp
Warhammer	2 gp

The Crusades

Battle axe	5 gp
Bow	
Arrow, flight	3 sp/12
Arrow, sheaf	3 sp/6
Composite short bow	75 gp
Composite long bow	100 gp
Long	75 gp
Short	30 gp
Caltrop	2 gp/12
Crossbow	
Heavy crossbow	50 gp
Heavy quarrel	2 sp
Light crossbow	35 gp
Light quarrel	1 sp
Pellet bow	25 gp
Pellet	5 cp
Dagger	2 gp
Flail, footman's	15 gp
Flail, horseman's	8 gp
Hand/throwing axe	1 gp
Lance, Light	6 gp
Lance, Medium	10 gp
Lance, Heavy	15 gp
Mace, footman's	8 gp
Mace, horseman's	5 gp
Quarterstaff	—
Pick, footman's	8 gp
Pick, horseman's	7 gp
Polearm	
Bill	7 gp
Glaive	6 gp
Guisarme	5 gp
Halberd	10 gp
Spear	8 sp
Spear, long	5 gp
Staff sling	2 sp
Stinkpot	1 sp
Stone	—
Sword	
Broadsword	20 gp
Long sword	45 gp
Sabre	30 gp
Short sword	15 gp
Warhammer	2 gp

weapons that evolved to pierce or defeat armor have not been invented yet. It's good for Viking-like cultures and humanoid hordes.

The Dark Ages saw one very important innovation in Western Europe: the introduction of the stirrup. This allowed a mounted man to wield heavier weapons and deliver a stronger blow without fear of falling off his horse. This innovation signaled the beginning of the horseman's ascendancy on the battlefield. By the year A.D. 900, the most devastating weapon on the battle-

Weapons & Armor

field was the charge of heavy cavalry. No infantry formation could hope to withstand it, and lighter cavalry had to move aside or be crushed.

In the West, armor was generally light until late in this period. Chain mail was too expensive for anyone except chieftains and picked bodyguards. By the end of the Dark Ages, chain mail had become far more prevalent. Metal lamellar and scale were widely used in Byzantine and Muslim armies, although light infantry usually did without any armor at all.

The Crusades

The Crusaders fought their way to the Holy Land at the end of the 11th century and founded kingdoms that would last almost 200 years. This is often referred to as the Age of Mail; chain mail was the prevalent form of personal protection throughout this period. By the time of the Crusades, the armored knight had become the heavy cavalry of Western Europe. It was said that a Crusader charge could carry "through the walls of Babylon."

The knights of the First Crusade were unruly, quarrelous, and impetuous. They had little grasp of battlefield tactics or maneuvers. The Syrians, Turks, and Fatimids who faced them were often commanded by noble warriors who displayed great skill and subtlety with their armies. But as often as not the Crusaders won the day through sheer hard fighting and weight of armor. It was not unusual for a band of Crusaders to take on a force of Turks or Syrians several times its own size and prevail.

The Crusades saw several important technological innovations. Chain mail hauberks were now augmented by chain mittens and leggings for complete protection. Crossbows first saw widespread use at this time. They proved especially useful for

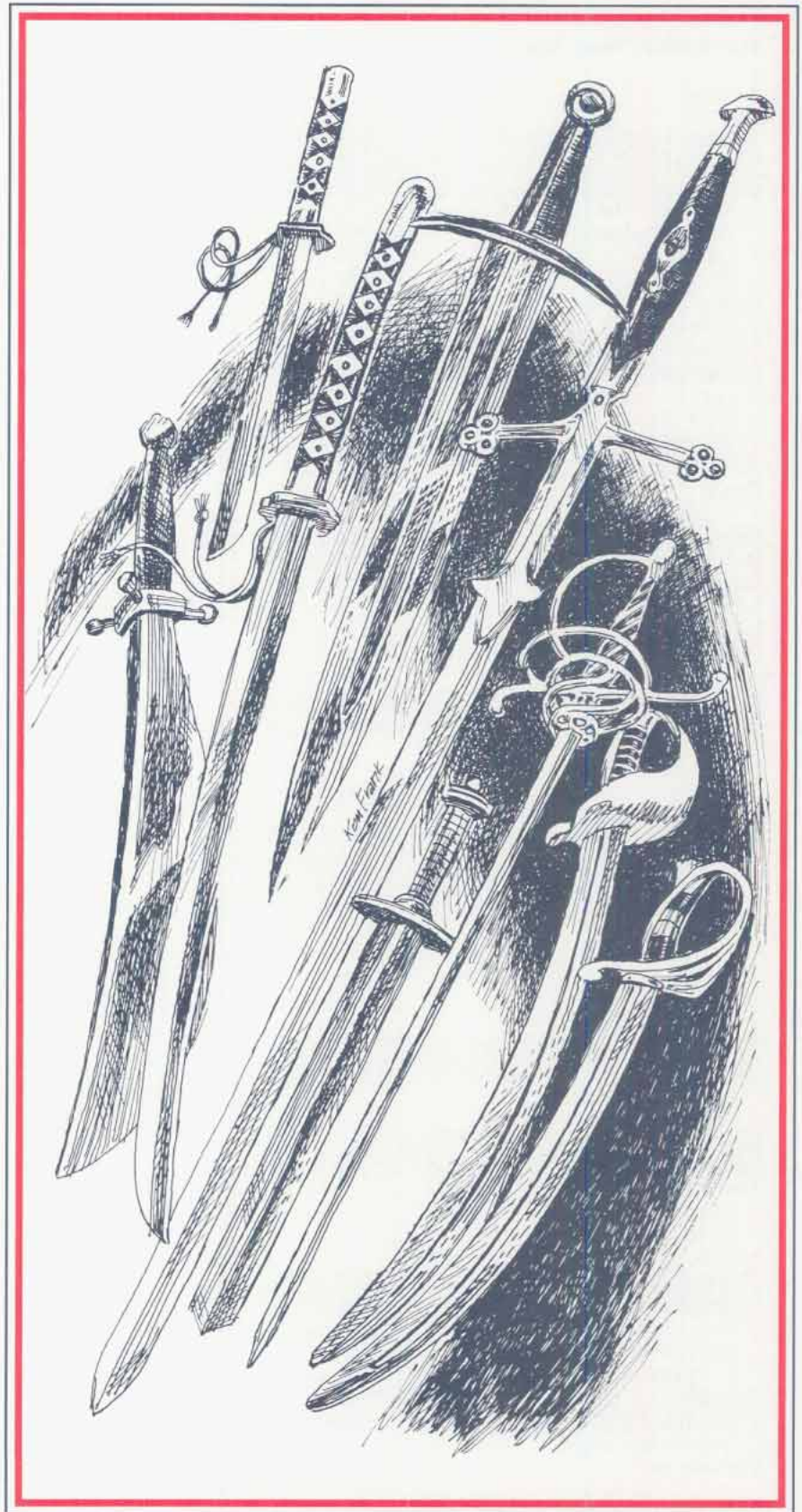

Chapter Seven

The Hundred Years' War

Battle axe	5 gp
Bow	
Arrow, flight	3 sp/12
Arrow, sheaf	3 sp/6
Arrow, pile	3 sp/6
Composite short	75 gp
Composite long	100 gp
Long	75 gp
Short	30 gp
Caltrop	2gp/12
Crossbow	
Heavy crossbow	50 gp
Heavy quarrel	2 sp
Light crossbow	35 gp
Light quarrel	1 sp
Pellet bow	25 gp
Pellet	5 cp
Dagger	2 gp
Stiletto	8 sp
Flail, footman's	15 gp
Flail, horseman's	8 gp
Hand/throwing axe	1 gp
Lance, Light	6 gp
Lance, Medium	10 gp
Lance, Heavy	15 gp
Lance, Jousting	20 gp
Mace, footman's	8 gp
Mace, horseman's	5 gp
Maul	4 gp
Morningstar	10 gp
Pick, footman's	8 gp
Pick, horseman's	7 gp
Polearm	
Awl Pike	5 gp
Bardiche	7 gp
Bec de Corbin	8 gp
Bill	7 gp
Bill-Guisarme	7 gp
Fauchard	5 gp
Glaive	6 gp
Glaive-Guisarme	10 gp
Guisarme	5 gp
Halberd	10 gp
Lucern hammer	7 gp
Military fork	5 gp
Quarterstaff	—
Spear	8 sp
Staff sling	2 sp
Stinkpot	1 sp
Stone	—
Sword	
Bastard Sword	25 gp
Broadsword	10 gp
Estoc	14 gp
Falchion	17 gp
Long sword	15 gp
Sabre	17 gp
Short sword	10 gp
Two-handed sword	50 gp
Warhammer	2 gp

The Renaissance

Battle axe	5 gp
Brandistock	15 gp
Bow	
Arrow, flight	3 sp/12
Arrow, sheaf	3 sp/6
Arrow, pile	3 sp/6
Composite short bow	75 gp
Composite long bow	100 gp
Long	75 gp
Short	30 gp
Caltrop	2 gp/12
Crossbow	
Heavy crossbow	50 gp
Heavy quarrel	2 sp
Light crossbow	35 gp
Light quarrel	1 sp
Pellet bow	25 gp
Pellet	5 cp
Dagger	2 gp
Main-gauche	3 gp
Parrying dagger	5 gp
Stiletto	8 sp
Flail, footman's	15 gp
Flail, horseman's	8 gp
Hand/throwing axe	1 gp
Lance, Medium	10 gp
Lance, Heavy	15 gp
Lance, Jousting	20 gp
Mace, footman's	8 gp
Mace, horseman's	5 gp
Mancatcher	30 gp
Maul	4 gp
Morningstar	10 gp
Quarterstaff	—
Pick, footman's	8 gp
Pick, horseman's	7 gp
Polearm	
Awl Pike	5 gp
Bill	7 gp
Bill-Guisarme	7 gp
Glaive-Guisarme	10 gp
Halberd	10 gp
Military fork	5 gp
Partisan	10 gp
Ranseur	6 gp
Spetum	5 gp
Voulge	5 gp
Spear	8 sp
Sword	
Bastard sword	25 gp
Broadsword	10 gp
Claymore	25 gp
Cutlass	12 gp
Falchion	17 gp
Long sword	15 gp
Rapier	15 gp
Sabre	17 gp
Short sword	10 gp
Two-handed sword	50 gp
Warhammer	2 gp

Weapons & Armor



keeping horse archers away from a formation, since they outranged the cavalry's lighter bows. Crossbows also had excellent penetration power, punching through armor that could stop most bow shots.

At the end of this period, plate armor began to appear. At first, plates were used to increase the protection over the shoulders and chest of a mailed knight. Within a span of only 50 years, chain mail had been largely replaced.

In addition to the Crusades in the Holy Land, this era also saw the great Mongol conquests of Russia, Hungary, and Poland.

In game terms, the Crusades represent an early Middle Ages society. Without pikes and longbows to counter them, mailed knights owned the battlefield. A fair number of standard fantasy settings center on this level of technology; for example, the armies of J.R.R. Tolkien's Middle Earth are equipped with mail, shield, and long sword.

Hundred Years' War

In 1291, the city of Acre fell. It was the last of the Crusader domains in the Levant. After eight Crusades and almost 200 years of sporadic fighting, the Holy Land remained in the hands of the Muslims. Early in the 14th century, friction between the rulers of France and England led to the beginning of the Hundred Years' War in 1337.

Edward III, the King of England, led an expedition into France in 1346. On August 26th, the French Army met the English at Crécy. Blooded by years of hard fighting against the Welsh and the Scots, the English longbowmen decimated charge after charge from their prepared positions. By the end of the fighting, the flower of French chivalry lay dead on the field, with only a few hundred English losses to weigh against it. The armored knight had met his match.

The 14th century is the default technological level of most AD&D campaigns, representing the end of

the Middle Ages. Full plate armor had appeared, and with it a variety of weapons designed to pierce it. While the knight and his mount were protected by the heaviest and most complete armor ever seen, he no longer ruled the battlefield. Instead, the lowly infantryman became dominant due to the appearance of the longbow, the pike, and an assortment of polearms.

The Renaissance

Firearms continued to improve, replacing the bow and crossbow as the primary missile weapon on the battlefield. The French Army at the end of the Hundred Years' War finally defeated the English with a coordinated army of cavalry, pike, and gunnery. At the same time, the famous Swiss pikemen were learning that their

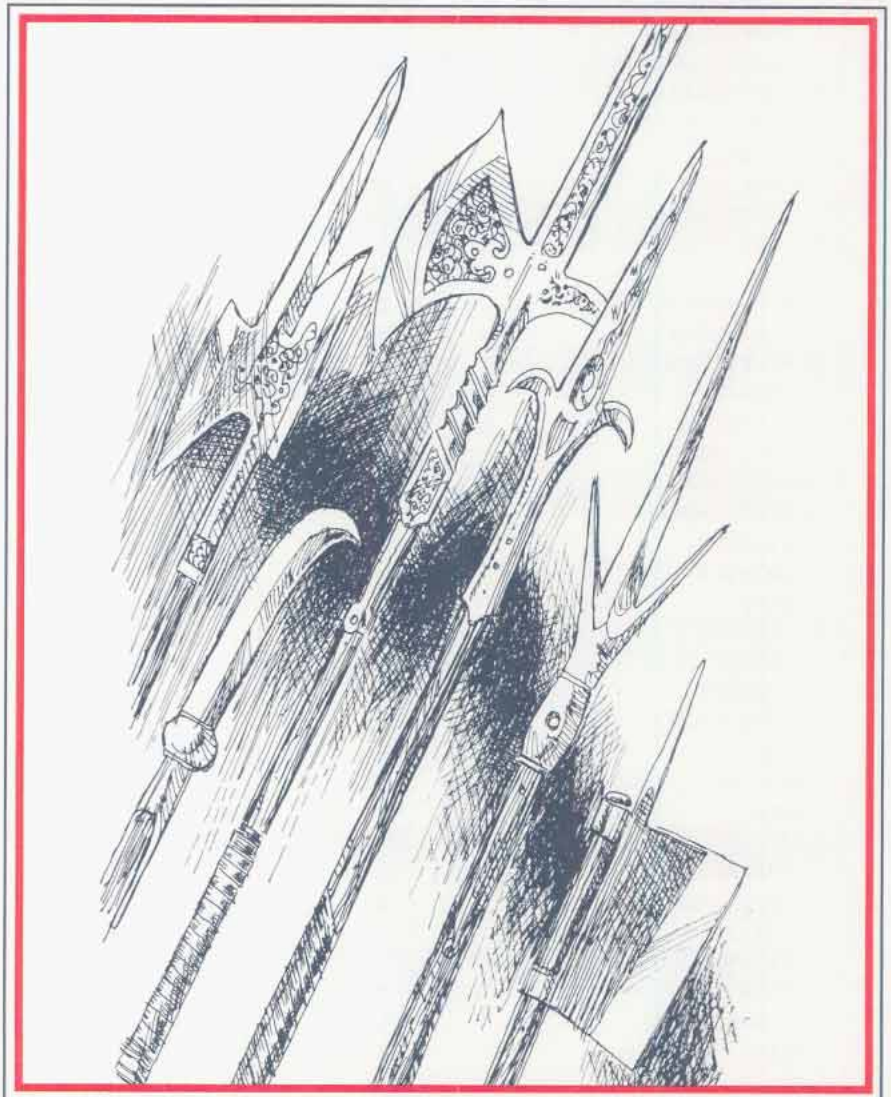

Chapter Seven

Middle Eastern Cultures

Ankus	3 gp
Bagh nakh	4 sp
Battle axe	5 gp
Blowgun	5 gp
Barbed dart	1 sp
Needle	2 cp
Bow	
Arrow, flight	3 sp/12
Composite long bow	100 gp
Composite short bow	75 gp
Short bow	30 gp
Chain	5 sp
Chakram	8 sp
Crossbow	
Hand quarrel	1 gp
Hand crossbow	150 gp
Heavy crossbow	50 gp
Heavy quarrel	2 sp
Light crossbow	35 gp
Light quarrel	1 sp
Pellet bow	25 gp
Pellet	5 cp
Dagger	2 gp
Jambiya	4 gp
Katar	3 gp
Dart	5 sp
Flail, footman's	15 gp
Flail, horseman's	8 gp
Hand/throwing axe	1 gp
Javelin	5 sp
Lance, light	6 gp
Lance, medium	10 gp
Mace, footman's	8 gp
Mace, horseman's	5 gp
Mancatcher	30 gp
Quarterstaff	—
Polearm	
Awl Pike	5 gp
Glaive	6 gp
Halberd	10 gp
Military fork	5 gp
Spear	8 sp
Spear, long	5 gp
Sword	
Cutlass	12 gp
Tulwar	17 gp
Long sword	15 gp
Sabre	17 gp
Scimitar	15 gp
Short sword	10 gp
Great scimitar	60 gp
Trident	15 gp

Oriental Weapons

Ankus	3 gp
Battle axe	5 gp
Blowgun	5 gp
Barbed dart	1 sp
Needle	2 cp
Bo stick	5 cp
Bow	
Arrow, flight	3 sp/12
Arrow, sheaf	3 sp/6
Composite long bow	100 gp
Composite short bow	75 gp
Short bow	30 gp
Chain	5 sp
Chakram	8 sp
Chijikiri	6 gp
Crossbow	
Light crossbow	35 gp
Light quarrel	1 sp
Pellet bow	25 gp
Pellet	5 cp
Cho-ku-no	50 gp
Dagger	2 gp
Dart	5 sp
Gunsen	4 gp
Hand axe	1 gp
Javelin	5 sp
Jitte	5 sp
Kama	2 gp
Kau sin ke	3 gp
Kawanaga	1 gp
Kusari-gama	4 gp
Lance, light	6 gp
Lance, medium	10 gp
Mace, footman's	8 gp
Mace, horseman's	5 gp
Mancatcher	30 gp
Nunchaku	5 sp
Polearm	
Awl Pike	5 gp
Lajatang	7 gp
Nagimaki	6 gp
Naginata	8 gp
Tetsubo	4 gp
Sai	1 gp
Sang kauw	5 gp
Shuriken	3 sp
Spear	8 sp
Spear, long	5 gp
Sword	
Cutlass	12 gp
Katana	100 gp
Ninja-to	20 gp
No-dachi	45 gp
Tulwar	17 gp
Sabre	17 gp
Short sword	10 gp
Wakizashi	50 gp
Three-piece rod	2 gp
Trident	15 gp

Weapons & Armor



tightly-packed formations were horribly vulnerable to field artillery. Despite the best efforts of armorers, hand-held firearms proved to be capable of downing a knight with a single shot.

The Renaissance was a period of change in warfare. At the beginning of this era, equipment and tactics were not very different from the late Middle Ages. Pikes and heavy cavalry were still the most common arms on the European battlefield. By the end of the 16th century, guns had replaced lances, pikes, and bows as the weapon of choice for the armies of Europe.

The Renaissance culminated in the Thirty Years' War and the English Civil War. In both of these conflicts, firearms proved their superiority over older weapons. By 1650, the armored knight was a figure of history, and the pike and bow were vanishing as well.

An AD&D campaign in a Renaissance setting actually travels beyond the original scope of the game. Characters can no longer rely on heavy armor to protect them; most of their foes are equipped with firearms that can penetrate the finest plate armor. The power of a PC party's massed musket fire makes even 1st-level characters the equal of an ogre or troll. And the existence of high magic becomes hard to justify in an Age of Reason.

The military systems developed by the Europeans in this time period would prove to be invincible to less advanced cultures as European explorers began the conquest of the world around them. Many neighboring peoples, such as the Turks or the Cossacks, began to fall behind the European powers during this era. By the time the Turks had matchlocks, the Europeans had flintlocks; by the time the Turks had flintlocks, the

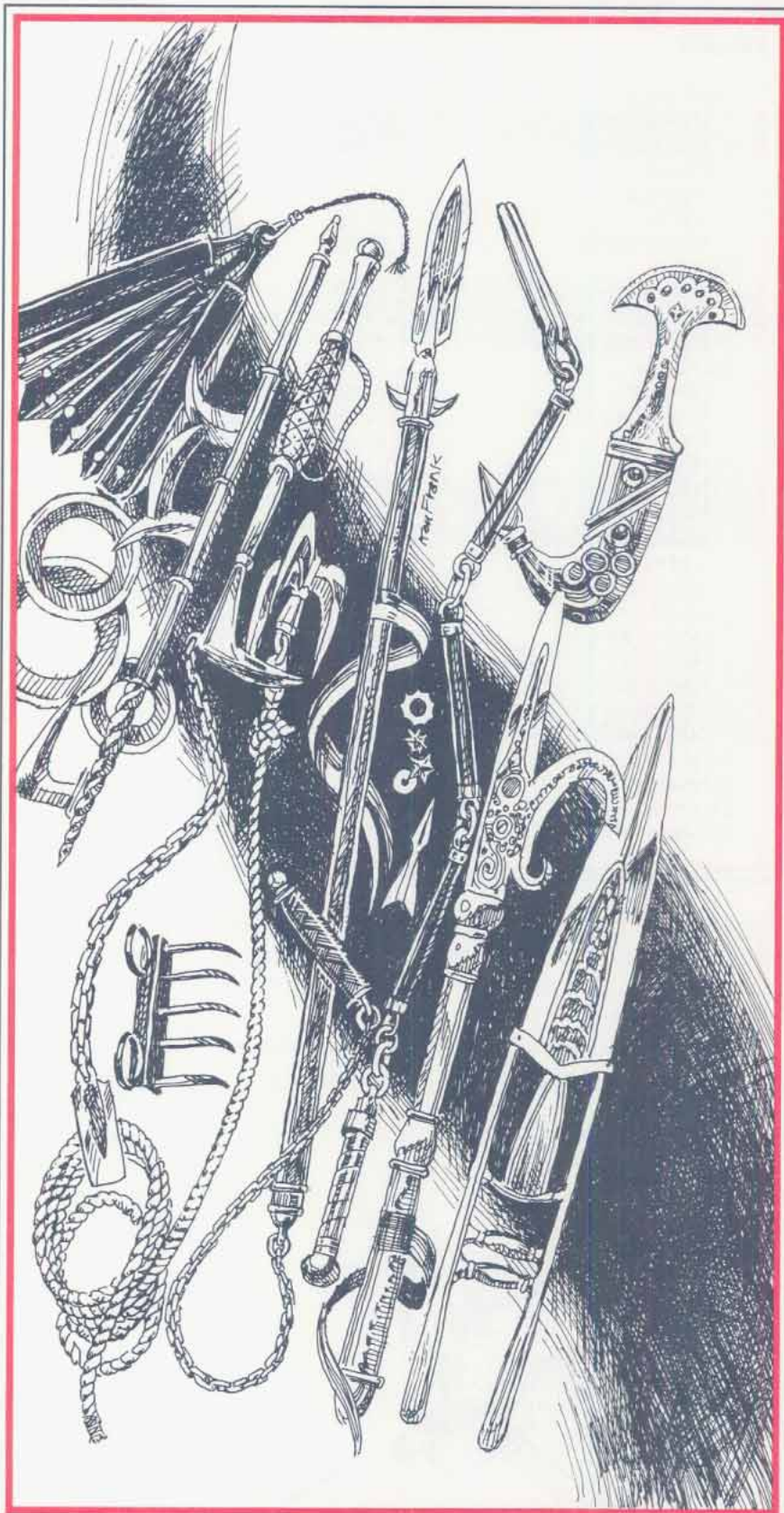

Chapter Seven

Firearms

Hand Match	
Handgunne	125 gp
Arquebus	175 gp
Matchlock	
Arquebus	50 gp
Caliver	40 gp
Musket w/rest	45 gp
Wheellock	
Arquebus	80 gp
Belt pistol	25 gp
Horse pistol	35 gp
Snaplock	
Belt Pistol	15 gp
Horse Pistol	20 gp
Musket	60 gp
Flintlock	
Belt Pistol	30 gp
Blunderbuss	20 gp
Blunderbuss Pistol	35 gp
Carbine	65 gp
Horse Pistol	40 gp
Musket	90 gp
Combined Weapons	
Axe-pistol	45 gp
Dagger-pistol	40 gp
Hammer-pistol	50 gp
Sword-pistol	75 gp
Bullet	1sp/10
Gunpowder	1 sp
Slow match	5 sp
Smokepowder	25 gp

Europeans had very good flintlocks. The upshot of this is that a kingdom with Renaissance-level technology is capable of defeating and dominating larger but less advanced societies.

Needless to say, this represents the most advanced technology available in a standard AD&D campaign.

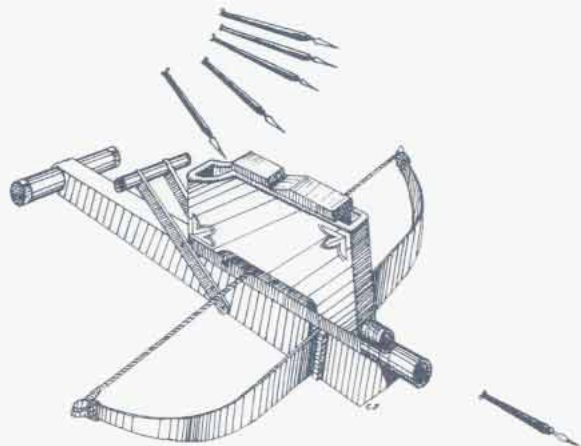

Middle Eastern

Unlike the previous categories, which trace a semi-historical progression of armaments, this grouping represents a generic Arabian or Moorish culture. Weapons such as scimitars and jambiyas aren't normally available in any kind of European setting, but they're common in lands with a Middle Eastern flavor.

No Middle Eastern cultures ever developed heavy plate armor, but excellent varieties of chain mail and reinforced chain mail were available for heavy cavalry. Foot troops were usually unarmored. Both straight and curved sword blades were common throughout the Arab world. Bows were also greatly favored, and the composite bow of the Turks was the most powerful in the world.

Many of the weapons on this list aren't true contemporaries of each other, or come from widely scattered areas. For example, the chakram, tulwar, and bagh nakh are Indian weapons, and couldn't be found in a Turkish or Bedouin venue. If there is any question about which weapons are available, the DM can decide if a particular weapon belongs in his campaign or not. Although there is no historical relation, this equipment grouping also covers Central Asian nomads such as Tartars or Mongols.

Oriental

As with the Middle Eastern grouping, the Oriental grouping is meant to provide a variety of weapons for flavor. It wouldn't feel right for a samurai warrior to equip himself with a pole axe or a pilum. Once again, the weapons list covers a lot of time and territory; the DM is free to rule out any weapon she doesn't feel is appropriate for her campaign.

Oriental armors were almost always varieties of lamellar, brigandine, or scale, even though they were known by different names. The characteristic armor of the samurai was usually a fine suit of metal lamellar armor.

Firearms

This listing sums up all firearms available from the other groupings. It was separated from the main equipment listings because the use of firearms in an AD&D campaign is purely optional. Firearms require an explosive powder to propel their missiles; this can be either *smoke powder* or *gunpowder*.

Weapons & Armor



Gunpowder is a mixture of saltpeter, sulfur, and charcoal. Generally, it is available only in low-magic campaigns. If gunpowder is widely available in a given setting, firearms will naturally be more common. If the DM rules that gunpowder works in his campaign, it can be purchased at the listed cost. In a realistic setting, gunpowder is cheap and easy to obtain.

Smoke powder is a magical compound that duplicates the effects of gunpowder. If the DM wishes to have firearms in his campaign but wants to limit their availability, he can decide that normal gunpowder doesn't work. Smoke powder is much scarcer and far more expensive than regular gunpowder, and player characters will usually have to find some instead of being able to buy it.

Of course, if the DM wants no guns of any kind in his campaign, he can rule that neither gunpowder nor smoke powder work on his world. Without powder, guns are useless.

Armor

This list sums up the types of armor available by each time period. There are two prices listed for each piece of equipment: a common price and a rare price. Generally, armor is rare when some other type of armor is prevalent. For example, plate mail is rare in a Crusades-era campaign, and therefore more expensive than in a Hundred Years' War-era setting.

The armor table also provides information on pieces of armor used together. It was quite common for armor to be "mismatched;" the hoplite of ancient Greece wore a bronze breastplate, greaves, and helmet with a leather skirt, while the Moghul Indians used an iron breastplate sewn into a complete suit of chainmail.

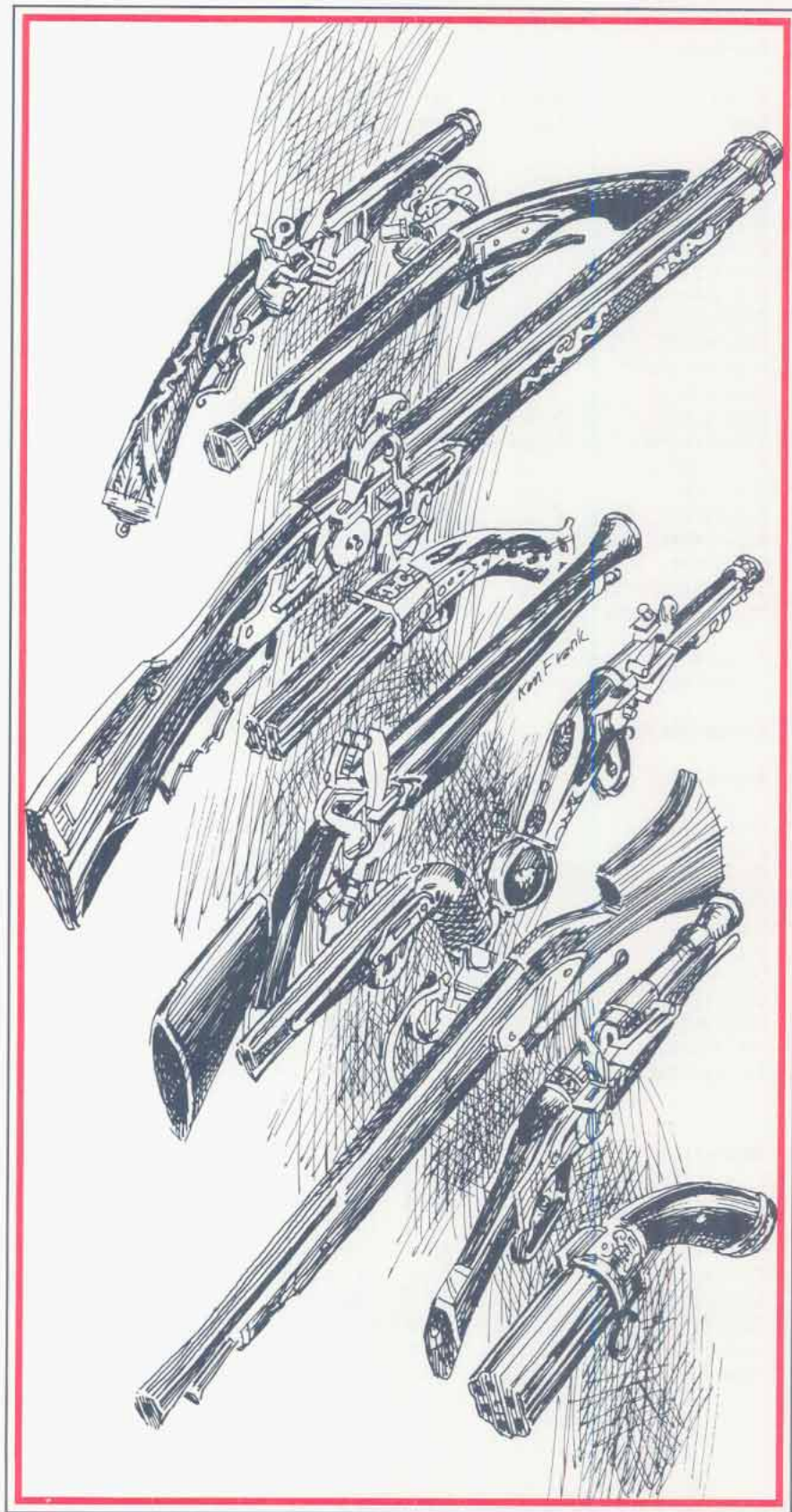

Chapter Seven

Full Suits

Armor Type	Common Cost	Rare Cost	Torso AC	Torso Weight	Arm AC	Arm Weight	Leg AC	Leg Weight	Full AC	Full Weight
Banded mail ⁺	200 gp	275 gp	3.0	17 lbs	0.6	4 lbs	0.9	5 lbs	6	35 lbs
Brigandine	120 gp	150 gp	2.0	15 lbs	0.4	3 lbs	0.6	4 lbs	4	30 lbs
Bronze plate ⁺	400 gp	750 gp	3.0	23 lbs	0.6	4 lbs	0.9	7 lbs	6	45 lbs
Chain mail ⁺⁺	75 gp	225 gp	2.5	20 lbs	0.5	4 lbs	0.8	6 lbs	5	40 lbs
Cord armor	10 gp	15 gp	1.0	8 lbs	0.2	1 lb	0.3	2 lbs	2	15 lbs
Field plate	2000 gp	3000 gp	4.0	30 lbs	0.8	6 lbs	1.2	9 lbs	8	60 lbs
Full plate	4000 gp	—	4.5	35 lbs	0.9	7 lbs	1.4	10 lbs	9	70 lbs
Hide armor	35 gp	50 gp	2.0	15 lbs	0.4	3 lbs	0.6	4 lbs	4	30 lbs
Improved mail ⁺⁺	180 gp	300 gp	3.0	25 lbs	0.6	5 lbs	0.9	8 lbs	6	50 lbs
Leather armor	5 gp	—	1.0	8 lbs	0.2	1 lb	0.3	2 lbs	2	15 lbs
Light scale ⁺⁺	80 gp	120 gp	1.5	13 lbs	0.3	2 lbs	0.5	4 lbs	3	25 lbs
Metal lamellar	250 gp	330 gp	2.5	17 lbs	0.5	4 lbs	0.8	5 lbs	5	35 lbs
Padded armor	4 gp	—	1.0	5 lbs	0.2	1 lb	0.3	1 lb	2	10 lbs
Plate mail	600 gp	900 gp	3.5	25 lbs	0.7	5 lbs	1.0	8 lbs	7	50 lbs
Ring mail	40 gp	40 gp	1.5	15 lbs	0.3	3 lbs	0.5	4 lbs	3	30 lbs
Scale armor	60 gp	80 gp	2.0	20 lbs	0.4	4 lbs	0.6	6 lbs	4	40 lbs
Splint mail	80 gp	600 gp	3.0	20 lbs	0.6	4 lbs	0.9	6 lbs	6	40 lbs
Studded leather	20 gp	40 gp	1.5	13 lbs	0.3	2 lbs	0.5	4 lbs	3	25 lbs
Wood/bone armor ⁺	50 gp	50 gp	1.5	10 lbs	0.3	2 lbs	0.5	3 lbs	3	20 lbs

* Historically, these armor types only existed as pieces and not full suits.

** Depending on the period, these armor types may only be available as pieces.

Composite Armors

Armor Type	Cost	Components	AC bonus	Weight
Back-and-breast	80 gp	Plate mail breastplate	4	25 lbs
Chain hauberk	75 gp	Thigh-length coat of mail	4	35 lbs
Chain-lamellar	125 gp	Lamellar breastplate, mail for limbs	6	35 lbs
Gallic armor	30 gp	Leather leggings and sleeve, metal belt	2	10 lbs
Half-plate	300 gp	Back-and-breast, partial leg and arm plate	6	40 lbs
Hoplite armor	160 gp	Bronze breastplate, greaves, leather skirt	5	40 lbs
Lamellar shirt	100 gp	Lamellar coat, cloth skirt	3	20 lbs
Lorica hamata	120 gp	Chain shirt, studded leather skirt	4	25 lbs
Lorica segmenta	175 gp	Banded mail shirt, studded leather skirt	5	20 lbs
Mail and plate	150 gp	Breastplate over chainmail	6	45 lbs
Three-quarter plate	800 gp	Full plate torso and arms, partial legs	7	45 lbs

Helmets

Type	AC	Cost	Weight	Surprise
Cap	6	4 gp	3 lbs	normal
Close-faced	3	20 gp	10 lbs	-1 penalty
Mail coif	5	10 gp	5 lbs	normal
Great helm	1	80 gp	20 lbs	-2 penalty
Leather helm	8	1 gp	2 lbs	normal
Open-faced	4	12 gp	7 lbs	-1 penalty

Shields

Type	AC Mod	# Foes	Cost	Weight
Buckler	+1	1	1 gp	3 lbs
Small	+1	2	3 gp	5 lbs
Medium	+1	3	7 gp	7 lbs
Large	+2	4	10 gp	15 lbs

Weapons & Armor



Master Weapon List

The table that follows includes all of the other following weapon statistics.

Weight: This is the weapon's weight in pounds. Some weapons have a negligible weight, but a group of 10 weigh one pound.

Size: Weapons are described as Small, Medium, or Large. A character can employ a weapon equal to his own size in one hand and can employ a weapon one size larger in two hands. A size S gnome can use a dagger or short sword one-handed, but he would need two hands to use a size M battle axe.

Type: Weapons are divided into three categories: Bludgeoning, Piercing, and Slashing. This describes the weapon's method of creating injuries and is used to determine what kind of critical hits the weapon inflicts. In addition, some monsters may be partially resistant to the effects of certain weapon types; for example, skeletons only take $\frac{1}{2}$ damage from slashing or piercing weapons.

Speed: Weapons are rated as *fast*, *average*, or *slow* for purposes of the PLAYER'S OPTION combat system. In addition, a number is included after the category to reflect the weapon's speed factor under standard AD&D rules. If the PLAYER'S OPTION combat system is not being used in a campaign, the speed factors are used instead.

Melee Reach: All hand-to-hand weapons are rated as having a reach of 1, 2, or 3 squares. A reach of 1 allows the user to attack any target in an adjacent square that he threatens, a range of 2 allows the user to attack targets one or two spaces away, and so on. A weapon with a range of 3 *cannot* be used to attack a target only 1 square away; it can only attack targets 2 or 3 squares away.

If a weapon has a "—" in this category, it cannot be used to make melee attacks.

Missile ROF: This is the number of times per combat round that a missile weapon may be used to attack. Naturally, a character can't throw two or three weapons per round if he only has one available.

Missile Range: Range is expressed as three numbers. The first number is the outermost limit of short range, the second is the outermost limit of medium range, and the third is the outermost limit of long range. For example, a thrown dagger has a range of 2/4/6. If it is thrown at a target one or two squares away, it's a short-range shot; a target three or four squares away is a medium-range shot; and so on.

Missile ranges are given in combat system squares. In normal melee scale, a square equals 5 feet. In missile scale (only used for outdoors or open battlefields) a square equals 5 yards.

Damage: Damage is divided into two categories: versus Small–Medium creatures, and versus Large or larger creatures. The target size dictates which rating to use.

Knockdown: The knockdown die is rolled any time the weapon scores a hit. A result of 7 or better creates a possible knockdown against a Man-sized target.

Weapon Descriptions

Adze. Resembling an axe with a sideways blade, the adze is a common tool. Some savage tribes use a short-handled war adze as a close-combat weapon. Common adzes can be found in most woodworkers' shops.

Ankus. The ankus is an elephant goad. It is a three-to four-foot staff with a metal hook and point at one end. The ankus was intended to be both a tool and a weapon, and some were used as elaborate ceremonial pieces.

Axe, stone. This crude weapon consists of an edged piece of stone lashed to a wooden haft. Normally, it's only found in the most primitive of settings.

Bagh nakh. Also known as "tiger claws," a bagh nakh is a set of metal blades worn on the palm. It is used with a cat-like clawing motion. Usually, the bagh nakh is used in pairs, one on each hand. It is available only in Indian or Oriental settings.

Battle axe. Hundreds of variations on the battle axe exist. Generally, any heavy axe that can be used one-handed or two-handed falls into this category. (If an axe can only be used two-handed, it's a two-handed axe.) Battle axes often have a spike, hammer, or smaller blade backing the primary blade. In some cases, both blades are equal in size in weight and can be used interchangeably.

Other names for a battle axe include the *bullova*, *bearded axe*, *bipennis*, and *war axe*.

Belaying pin. This is a weapon of convenience for sailors of any campaign. Belaying pins are used to secure the lines of a ship's rigging, and there's always one nearby on the deck of a ship.

Blowgun. Blowguns can fire two types of ammunition: a barbed dart, suitable for hunting small fowl, and a needle for carrying poison. Most blowguns are six or seven feet in length, although assassins might carry a

Chapter Seven

Weapon	Wt.	Size	Type	Speed	Melee Reach	Missile ROF	Range S/M/L	Damage vs. Size Sm-Med	Large	Knockdown
Adze	4	S	S/P	Fa(4)	1	—	—	1d4+1	1d4	d6
Ankus	4	M	P/B	Av(6)	1	—	—	1d4	1d4	d8
Axe										
Battle	7	M	S	Av(7)	1	—	—	1d8	1d8	d10
Hand/throwing	5	M	S	Fa(4)	1	1/md	2/4/6	1d6	1d4	d8
Stone	6	M	B/S	Av(6)	1	—	—	1d6	1d4	d8
Two-handed ^h	10	L	S	Sl(9)	1	—	—	1d10	2d8	d12
Bagh nakh	1	S	S	Fa(2)	1	—	—	1d2	1d2	d4
Belaying pin	2	S	B	Fa(4)	1	—	—	1d3	1d3	d6
Blowgun ^h	2	L	—	Av(5)	—	2/md	2/4/6	—	—	—
Barbed dart	*	S	P	—	—	2/md	2/4/6	1d3	1d2	d4
Needle ¹	*	S	P	—	—	2/md	2/4/6	1	1	—
Bo stick ⁴	4	L	B	Fa(3)	1	—	—	1d6	1d4	d8
Bolas	2	M	B	Sl(8)	—	1/md	6/12/18	1d3	1d2	d6
Boomerang ²	2	S	B	Fa(4)	1	1/md	4/8/12	1d4	1d4	d8
Bottle ^b	2	S	B	Fa(4)	1	1/md	2/3/4	1d3	1d2	d6
Bow										
Composite long ^h	3	L	(P)	Av(7)	—	2/md	—	—	—	d6
w/flight arrow	*	S	P	—	—	—	12/24/42	1d6	1d6	d6
w/pile arrow	*	S	P	—	—	—	8/16/34	1d6	1d6	d6
w/sheaf arrow	*	S	P	—	—	—	8/16/34	1d8	1d8	d6
w/stone arrow ^b	*	S	P	—	—	—	12/24/42	1d4	1d4	d6
Composite short ^h	2	M	(P)	Av(6)	—	2/md	—	—	—	—
w/flight arrow	*	S	P	—	—	—	10/20/36	1d6	1d6	d6
w/stone arrow ^b	*	S	P	—	—	—	10/20/36	1d4	1d4	d6
Long ^h	3	L	(P)	Av(7)	—	2/md	—	—	—	—
w/flight arrow	*	S	P	—	—	—	14/28/42	1d6	1d6	d6
w/sheaf arrow	*	S	P	—	—	—	10/20/34	1d8	1d8	d6
w/pile arrow	*	S	P	—	—	—	10/20/34	1d6	1d6	d6
w/stone arrow	*	S	P	—	—	—	14/28/42	1d4	1d4	d6
Short ^h	2	M	(P)	Av(7)	—	2/md	—	—	—	—
w/flight arrow	*	S	P	—	—	—	10/20/30	1d6	1d6	d6
w/stone arrow	*	S	P	—	—	—	10/20/30	1d4	1d4	d6
Brandistock	5	M	P	Av(7)	1	—	—	1d6	1d6	d8
Caltrop	*	S	P	—	—	—	—	1	1d2	—
Cestus	2	S	B	Fa(2)	1	—	—	1d4	1d3	d6
Chain ^{h, s}	3	L	B	Av(5)	2	—	—	1d4+1	1d4	d6
Chakram	1	S	S	Fa(4)	—	2/md	4/8/12	1d4	1d3	d4
Chijikiri ^h	6	M	P/B	Av(7)	1(2)	—	—	1d6	1d8	d6
Club	3	M	B	Fa(4)	1	1/md	2/4/6	1d6	1d3	d8
Great	15	L	B	Sl(9)	1	—	—	2d4	1d6+1	d12
War	6	M	B/S	Av(7)	1	1/md	2/4/6	1d6+1	1d4+1	d10
Combined Weapons										
Axe-pistol	6	M	S	Fa(4)	1	as per wheellock belt pistol	—	1d6	1d4	d8
Dagger-pistol	3	S	P	Fa(2)	1	as per wheellock belt pistol	—	1d4	1d3	d6
Hammer-pistol	5	M	B	Fa(4)	1	as per wheellock belt pistol	—	1d4+1	1d4	d10
Sword-pistol	6	M	S	Av(5)	1	as per wheellock belt pistol	—	2d4	1d6+1	d8
Crossbow										
Cho-ku-no ^h	12	M	—	Av(6)	—	2/md	10/20/30	—	—	—
Hand	3	S	—	Av(5)	—	1/md	—	—	—	—
Hand quarrel	*	S	P	—	—	—	4/8/12	1d3	1d2	d4
Heavy ^h	14	M	—	Sl(10)	—	½ md	—	—	—	—
Heavy quarrel	*	S	P	—	—	—	16/32/48	1d8+1	1d10+1	d6
Light ^h	7	M	—	Av(7)	—	1/md	—	—	—	—
Light quarrel	*	S	P	—	—	—	12/24/36	1d6+1	1d8+1	d6
Pellet bow ^h	5	M	—	Av(7)	—	1/md	—	—	—	—
Pellet	*	S	B	—	—	—	8/16/24	1d4	1d4	d4
Dagger	1	S	P	Fa(2)	1	2/md	2/4/6	1d4	1d3	d6
Bone ^b	1	S	P	Fa(2)	1	2/md	2/3/4	1d2	1d2	d6
Jambiya	1	S	P/S	Fa(3)	1	—	—	1d4	1d4	d6
Katar	1	S	P	Fa(2)	1	—	—	1d3+1	1d3	d6

Weapons & Armor



Weapon	Wt.	Size	Type	Speed	Melee Reach	Missile ROF	Range S/M/L	Damage vs. Size		
								Sm-Med	Large	Knockdown
Main-gauche	2	S	P/S	Fa(2)	1	—	—	1d4	1d3	d6
Parrying	1	S	P	Fa(2)	1	—	—	1d3	1d3	d6
Stiletto	½	S	P	Fa(2)	1	2/md	2/4/6	1d3	1d2	d4
Stone ^b	1	S	P	Fa(2)	1	2/md	2/3/4	1d3	1d2	d6
Dart	½	S	P	Fa(2)	—	3/md	2/4/8	1d3	1d2	d4
Flail										
Footman's	15	L	B	Av(7)	1	—	—	1d6+1	2d4	d12
Grain	3	M	B	Av(6)	1	—	—	1d4	1d4	d8
Horseman's	5	M	B	Av(6)	1	—	—	1d4+1	1d4+1	d10
Flintlock ³										
Belt Pistol	3	S	P	Av(7)	—	1/2 m	4/8/12	1d8 ^k	1d8 ^k	d8
Blunderbuss Pistol ⁴	6	S	P	Sl(9)	—	1/3 m	2/4/8	1d6	1d6	d10
Blunderbuss ⁴	10	M	P	Sl(10)	—	1/3 m	3/6/12	1d8	1d8	d12
Carbine	8	M	P	Av(8)	—	1/2 m	10/20/55	1d10 ^k	1d10 ^k	d8
Horse Pistol	4	S	P	Av(8)	—	1/2 m	5/10/15	1d10 ^k	1d10 ^k	d8
Musket	12	M	P	Sl(9)	—	1/2 m	15/30/80	1d12 ^k	1d12 ^k	d8
Fork	6	L	P	Av(7)	1	—	—	1d6	1d6+1	d6
Gaff/hook	2	S	P	Fa(2)	1	—	—	1d4	1d3	d4
Grapple	3	S	P/B	Av(7)	1	1/2 md	2/4/6	1d4	1d4	d6
Gunpowder	*	—	—	—	—	—	—	—	—	—
Gunsen	1	S	B/P	Fa(2)	1	—	—	1d3	1d2	d4
Hammer	3	S	B	Fa(4)	1	1/md	2/4/6	1d4	1d3	d6
Hand Match ⁵										
Arquebus	10	M	P	Vsl(15)	—	1/3 m	10/30/42	1d10 ^k	1d10 ^k	d8
Handgunne	20	L	P	Vsl(18)	—	1/4 m	8/24/34	1d8+2	2d6+2	d10
Harpoon ^h	6	L	P	Av(7)	2	1/md	2/4/6	2d4	2d6	d8
Bone ^{b, h}	5	L	P	Av(7)	2	1/md	2/3/4	1d6	1d10	d8
Hatchet	3	S	S	Fa(3)	1	1/md	2/4/6	1d4	1d4	d6
Holy symbol, big	4	S	B	Av(5)	1	—	—	1d6	1d3	d8
Javelin	2	M	P	Fa(4)	1	1/md	4/8/12	1d6	1d6	d6
Stone ^b	2	M	P	Fa(4)	1	1/md	3/6/9	1d4	1d4	d6
Jitte	2	S	B	Fa(2)	1	—	—	1d4	1d2	d6
Kama	2	S	P/S	Fa(4)	1	—	—	1d6	1d4	d6
Kau sin ke	4	M	B	Av(6)	1	—	—	1d8	1d6	d8
Kawanaga ^h	1	S	P/B	Av(7)	2	—	—	1d3	1d2	d6
Knife	½	S	S/P	Fa(2)	1	2/md	2/4/6	1d3	1d2	d4
Bone ^b	½	S	P/S	Fa(2)	1	2/md	2/3/4	1d2	1d2	d4
Stone ^b	½	S	P/S	Fa(2)	1	2/md	2/3/4	1d2	1d2	d4
Throwing	4	M	S/P	Sl(8)	1	1/md	2/4/6	2d4	1d6+1	d8
Kusari-gama ^h	3	M	P/S/B	Av(6)	2	—	—	1d6	1d4	d6
Lance										
Light ^m	5	L	P	Av(6)	2	1/md	2/3/4	1d6	1d8	d8
Medium ^m	10	L	P	Av(7)	2	—	—	1d6+1	2d6	d10
Heavy ^m	15	L	P	Sl(10)	2	—	—	1d8+1	3d6	d12
Jousting ^m	20	L	B	Sl(10)	2	—	—	1d3-1	1d2-1	d12
Lantern	2-3	S	B ^o	Av(6)	1	1/md	2/3/4	1d3*	1d2*	d6
Lasso	3	L	—	Sl(10)	—	1/2 md	2/4/6	—	—	—
Mace										
Footman's	10	M	B	Av(7)	1	—	—	1d6+1	1d6	d10
Horseman's	6	M	B	Av(6)	1	1/md	2/3/4	1d6	1d4	d8
Mace-axe	9	L	B/S	Sl(8)	1	—	—	2d4	1d6+1	d10
Machete	5	M	S	Av(6)	1	—	—	1d8	1d8	d6
Mancatcher ^{h, 6}	8	L	—	Av(7)	1	—	—	—	—	d6
Matchlock ⁷										
Arquebus	10	M	P	Sl(10)	—	1/2 md	10/20/60	1d10 ^k	1d10 ^k	d8
Caliver	11	M	P	Sl(9)	—	1/2 md	8/16/48	1d8 ^k	1d8 ^k	d8
Musket w/rest	20	L	P	Sl(12)	—	1/2 md	12/24/72	1d12 ^k	1d12 ^k	d8
Maul	10	L	B	Sl(8)	1	—	—	2d4	1d10	d12
Morningstar	12	M	B/P	Av(7)	1	—	—	2d4	1d6+1	d10
Net ^h	10	M	—	Sl(10)	1	1/2 md	2/3/4	—	—	—
Nunchaku ⁴	3	M	B	Fa(3)	1	½	½	1d6	1d6	d8

Chapter Seven

Weapon	Wt.	Size	Type	Speed	Melee Reach	Missile ROF	Range S/M/L	Damage vs. Size	Knockdown	
Oil flask	1	S		VS(15)	—	1/2 md	2/3/4	Sm-Med ^d	Large ^d	—
Parang or Machete Pick	5	M	S	Av(6)	1	—	—	1d8	1d8	d6
Farming tool	8	L	P	Sl(8)	1	—	—	1d6	1d6+1	d8
Footman's	6	M	P	Av(7)	1	—	—	1d6+1	2d4	d8
Horseman's	4	M	P	Av(5)	1	—	—	1d4+1	1d4	d6
Pike ^{c, h}	12	L	P	Sl(13)	3	—	—	1d6	1d12	d8
Pilum	3	M	P	Av(5)	1	1/md	3/6/9	1d6	1d6	d6
Polearm										
Awl Pike ^c	12	L	P	Sl(13)	3	—	—	1d6	1d12	d8
Bardiche	12	L	S	Sl(9)	2	—	—	2d4	2d6	d12
Bec de Corbin ^h	10	L	P/B	Sl(9)	2	—	—	1d8	1d6	d10
Bill-Guisarme ^h	15	L	P/S	Sl(10)	2	—	—	2d4	1d10	d10
Bill ^h	15	L	P/S	Sl(10)	2	—	—	2d4	1d10	d10
Fauchard	7	L	S	Sl(8)	2	—	—	1d6	1d8	d8
Glaive	8	L	S	Sl(8)	2	—	—	1d6	1d10	d10
Glaive-Guisarme ^h	10	L	P/S	Sl(9)	2	—	—	2d4	2d6	d10
Guisarme ^h	8	L	S	Sl(8)	2	—	—	2d4	1d8	d10
Halberd ^h	15	L	P/S	Sl(9)	2	—	—	1d10	2d6	d12
Lajatang	6	L	S	Av(6)	1	—	—	1d10	1d10	d8
Lucern hammer ^{c, h}	15	L	P/B	Sl(9)	2	—	—	2d4	1d6	d10
Military fork	7	L	P	Av(7)	2	—	—	1d8	2d4	d8
Nagimaki ^m	6	M	S	Av(6)	2	—	—	1d6	1d8	d6
Naginata ^m	10	L	S	Av(7)	2	—	—	1d8	1d10	d8
Partisan ^c	8	L	P	Sl(9)	2	—	—	1d6	1d6+1	d8
Ranseur ^c	7	L	P	Sl(8)	2	—	—	2d4	2d4	d8
Spetum ^c	7	L	P	Sl(8)	2	—	—	1d6+1	2d6	d8
Tetsubo	8	L	B	Av(7)	1	½	½	1d8	1d8	d12
Voulge	12	L	S	Sl(10)	2	—	—	2d4	2d4	d12
Pry bar	5	M	B	Av(5)	1	—	—	1d6	1d3	d8
Quarterstaff ^h	4	L	B	Fa(4)	1	—	—	1d6	1d6	d10
Rock	1	S	B	Fa(2)	1	2/md	2/4/6	1d3	1d2	d6
Sai ^a	2	S	B	Fa(2)	1	—	—	1d4	1d2	d6
Sang kauw ^{a, s}	10	L	P/S	Av(7)	1	—	—	1d8	1d6	d6
Sap	½	S	B	Fa(2)	1	—	—	1d2	1d2	d4
Scourge ^s	2	S	—	Av(5)	1	—	—	1d4	1d2	d4
Scythe	8	L	P/S	Sl(8)	1	—	—	1d6+1	1d8	d8
Shuriken	*	S	P	Fa(2)	—	2/md	3/6/9	1d4	1d4	d4
Sickle	3	S	S	Fa(4)	1	—	—	1d4+1	1d4	d4
Sledge hammer ^h	10	M	B	Sl(8)	1	—	—	1d6+1	1d4+1	d12
Sling	1	S	—	Av(6)	—	1/md	—	—	—	—
Bullet	*	S	B	—	—	—	10/20/40	1d4+1	1d6+1	d4
Stone	*	S	B	—	—	—	8/16/24	1d4	1d4	d4
Slow match	*	—	—	—	—	—	—	—	—	—
Smokepowder	*	—	—	—	—	—	—	—	—	—
Snaplock ^q										
Belt Pistol	3	S	P	Av(7)	—	1/2 md	3/6/9	1d8 ^a	1d8 ^a	d8
Horse Pistol	4	S	P	Av(8)	—	1/2 md	4/8/12	1d10 ^a	1d10 ^a	d8
Musket	14	M	P	Sl(9)	—	1/2 md	14/26/78	1d12 ^a	1d12 ^a	d8
Spade ^h	5	M	S/B	Av(7)	1	—	—	1d4	1d4	d8
Spear ^c	5	M	P	Av(6)	1	1/md	2/4/6	—	—	—
Normal										
One-handed	—	—	—	—	—	—	—	1d6	1d8	d6
Two-handed	—	—	—	—	—	—	—	1d6+1	2d6	d8
Long ^{c, h}	8	L	P	Sl(8)	2	—	—	2d6	3d6	d8
Stone ^b	5	M	P	Av(6)	1	1/md	2/3/4	—	—	—
One-handed	—	—	—	—	—	—	—	1d4	1d6	d6
Two-handed ^c	—	—	—	—	—	—	—	1d6	2d4	d8
Staff sling ^{h, 10}	2	M	—	Sl(11)	—	1/md	—	—	—	—
Stinkpot	2	S	B	—	—	—	6/12/18	1d3	1d3	d6
Stone	2	S	B	—	—	—	6/12/18	1d4+1	1d6+1	d6

Weapons & Armor



Weapon	Wt.	Size	Type	Speed	Melee Reach	Missile ROF	Range S/M/L	Damage vs. Size		
								Sm-Med	Large	Knockdown
Sword										
Bastard	10	M	S	Av(6)	1	—	—	—	—	—
One-handed	—	—	—	—	—	—	—	1d8	1d12	d8
Two-handed	—	—	—	—	—	—	—	2d4	2d8	d10
Broad-Claymore ^b	4	M	S	Av(5)	1	—	—	2d4	1d6+1	d8
Cutlass	4	M	S	Av(5)	1	—	—	1d6+1	1d8+1	d8
Drusus	3	M	S	Fa(3)	1	—	—	1d6+1	1d8+1	d6
Estoc	5	M	P	Av(5)	1	—	—	1d6	1d8	d6
Falchion	8	M	S	Av(5)	1	—	—	1d6+1	2d4	d8
Gladius	3	S	P	Fa(3)	1	—	—	1d6	1d8	d6
Katana	6	M	S/P	Fa(4)	1	—	—	—	—	—
One-handed	—	—	—	—	—	—	—	1d10	1d12	d6
Two-handed	—	—	—	—	—	—	—	2d6	2d6	d8
Khopesh	7	M	S	Sl(9)	1	—	—	2d4	1d6	d8
Long	4	M	S	Av(5)	1	—	—	1d8	1d12	d8
Ninja-to	5	M	S/P	Fa(3)	1	—	—	1d8	1d6	d6
No-dachi	10	L	S/P	Sl(8)	1	—	—	1d10	1d20	d10
Rapier	4	M	P	Fa(4)	1	—	—	1d6	1d8	d6
Sabre	5	M	S	Av(5)	1	—	—	1d6+1	1d8+1	d8
Sapara	4	S	S	Av(5)	1	—	—	1d6+1	1d4	d6
Scimitar	4	M	S	Av(5)	1	—	—	1d8	1d8	d8
Great	16	L	S	Sl(9)	1	—	—	2d6	4d4	d10
Short	3	S	P	Fa(3)	1	—	—	1d6	1d8	d6
Spatha	4	M	S	Av(5)	1	—	—	1d8	1d12	d8
Sword-axe	12	L	S	Sl(10)	1	—	—	1d8+1	1d12+1	d10
Tulwar	8	M	S	Av(5)	1	—	—	1d6+1	2d4	d8
Two-handed	15	L	S	Sl(10)	1	—	—	1d10	3d6	d12
Wakizashi	3	M	S/P	Fa(3)	1	—	—	1d8	1d8	d6
Three-piece rod ^{h,s}	5	L	B	Av(7)	1	—	—	1d6	1d4	d8
Torch	1	M	B ^d	Fa(4)	1	1/md	2/3/4	1d4	1d3	d6
Trident	5	L	P	Av(7)	1	1/md	2/3/4	—	—	—
One-handed	—	—	—	—	—	—	—	1d6+1	2d4	d6
Two-handed	—	—	—	—	—	—	—	1d8+1	3d4	d8
Vial ^b	*	S	^d	Fa(2)	—	1/md	2/3/4	^d	^d	—
Warhammer	6	M	B	Fa(4)	1	1/md	2/4/6	1d4+1	1d4	d8
Wheellock ^c										
Arquebus	8	M	P	Sl(8)	—	1/2 rnd	10/20/60	1d10 ^k	1d10 ^k	d8
Belt pistol	3	S	P	Av(7)	—	1/2 md	3/6/9	1d8 ^k	1d8 ^k	d8
Horse pistol	4	S	P	Av(8)	—	1/2 md	4/8/12	1d10 ^k	1d10 ^k	d8
Whip ^{l1}	2	M	—	Sl(8)	3	—	—	1d2	1	—

* These weapons weigh little individually. Ten of these weigh one pound.

^b Bone and stone weapons have a 1 in 6 chance of breaking any time maximum damage is rolled. For the bottle and the vial, any hit breaks the item unless a successful saving throw vs. normal blow is rolled. If a bottle is broken, it can then be used as a knife.

^c These weapons inflict double damage if firmly set to receive a charge.

^d These weapons may inflict additional damage from burning fuel, holy water, or acid.

^h These weapons require two hands to wield regardless of the wielder's size.

^k If the knockdown roll for these weapons is a 7 or higher, roll an additional damage die and add it to the original damage. Roll another knockdown die, and if the result is another 7 or higher, repeat the damage.

^m These weapons inflict double damage when wielded in a mounted charge.

^l These weapons can be used to perform special martial arts attacks.

¹ Poison is available for the blowgun needle only if the DM allows it.

² The boomerang returns only if it was thrown by a proficient user and misses its target.

³ Flintlock firearms misfire on a natural attack roll of 1.

⁴ The blunderbuss inflicts 1d4 separate attacks on targets at short range. It cannot cause additional damage like other firearms. See the weapon description.

⁵ All range penalties for hand match firearms are doubled, so medium-range shots have a -4 attack modifier and long range shots a -10 modifier. Hand match firearms misfire on a natural attack roll of 5 or less (10 or less in wet conditions).

⁶ The mancatcher dismounts a rider on a successful hit.

⁷ Matchlock firearms misfire on a natural attack roll of 3 or less (6 or less in wet conditions).

⁸ The scourge is ineffective against opponents in metal armor (scale mail or heavier).

⁹ Snaplock firearms misfire on a natural attack roll of 2 or less.

¹⁰ The staff sling has no short range. It cannot hit targets within 5 squares of the wielder, attacks made 6 to 12 squares away are considered to be at medium range, and attacks made 13 to 18 squares away are considered long range.

¹¹ The whip is ineffective against opponents in any type of armor.

Chapter Seven



miniature weapon two feet long that can only fire needles.

Blowgun ammunition is very light and cannot penetrate heavy armor. If a target is protected by a full suit of brigandine, mail, or plate of any kind, the attacker suffers an additional -4 to his attack roll.

Bo stick. This oriental staff is a tapering length of wood about four to six feet in length. The wielder of a bo stick suffers a -2 penalty to attacks against an opponent in plate armor of any kind.

Bolas. Bolas consist of two or three weights joined by a sturdy leather cord or rope. They have been used by hunters since the Stone Age. A character must be proficient with the bolas to throw them successfully. If the bolas hit their target, they automatically create a knockdown chance for their victim. If the victim fails his saving throw, he has to spend a full round and make a Strength check to be able to stand and move again.

Bolas can also be used for special called shots. A called shot at the target's arms will prevent the target from using his weapon or shield until he spends a round and succeeds in a Strength check. A called shot at the target's head wraps the bolas around his neck and begins to strangle him. He suffers 1d3 points of damage from strangulation each round until the bolas are removed or he dies.

A sharp knife, dagger, or similar short blade can be used to sever a bola's cords. This replaces the Strength check to get free, and is automatically successful. Of course, the victim must have an arm free to cut the bolas loose.

Boomerang. Another ancient hunting weapon, the boomerang is a heavy, aerodynamic club. It does not normally return to its thrower; a proficient user has to make a called shot to set up a throw that will return in the event of a miss.

Bottle. Bottles are found in taverns and alehouses all over the world. Each time a bottle hits, it must roll a successful saving throw vs. normal blow or break. A broken bottle can be wielded as if it were a knife.

Bow. One of the most common weapons throughout history is the bow. The simple self bow, or short bow, has been used for hunting and war since before the dawn of civilization. If a bow is made from a single piece of wood, it is a plain long or short bow; if it is made from laminated horn, wood, bone, or any other materials, it is a composite bow.

If a character has an unusually low Strength score, he *must* apply any attack or damage penalties to his archery. He is forced to use bows that have a lighter

pull. However, for a character to gain his bonuses for a high Strength score, he must get a custom-made bow, which costs 3–5 times the normal price. A higher-Strength character can always use a lower-Strength bow, gaining bonuses up to the maximum permitted by the bow. For example, a character with a Strength of 18/35 can use a bow made for a Strength of 17, gaining a $+1$ to hit and $+1$ to damage instead of his normal full bonuses.

Short bows can be found in any setting. Even if they are not used for war, they are the weapon of choice for many hunters. Short bows fire flight arrows or stone arrows.

Long bows are simply bigger short bows. They are drawn to the cheek, instead of being drawn to the chest as other bows are. Long bows can fire any kind of arrow. Long bows cannot be used from horseback.

Composite short bows are the favorite of horse archers everywhere. They can fire flight arrows or stone arrows.

Composite long bows are usually only found in eastern campaigns. They can be fired from horseback if they have been specially built for it, at twice the normal cost. Composite long bows fire any kind of arrow.

Flight arrows are the basic war or hunting arrow. They fly farther than sheaf arrows, which have a broader and heavier head for more damage. Pile arrows are constructed with small, dense points designed to pierce heavy armor. A pile arrow fired at short range penalizes the target's AC from armor by 2 points. This only applies to that portion of a target's armor that is derived from physical armor; Dexterity, cover, or magical bonuses are not affected.

For example, an archer fires a pile arrow at a warrior wearing chainmail +2 and a shield with a Dexterity of 16. The chainmail is considered to be 2 points worse, so it has a base AC of 7, not 5. Overall, the warrior's AC drops from 0 to 2. If the warrior wore nothing but bracers of defense (AC 4), his AC would not be affected.

Brandistock. The brandistock is an iron-shod walking staff that conceals three blades. When deployed, the blades form a small trident. In situations where the enemy isn't expecting a character to be so armed, the DM can assign a $+1$ surprise or initiative bonus.

Caltrop. A caltrop is a cluster of four or more iron spikes, designed so that one point is always facing up (they would look similar to a d4—one point is always

Weapons & Armor



up). They are intended to be scattered in the path of an enemy, who may step on one if he's not careful.

In order to be effective, at least 10 caltrops must be scattered in a 5'x5' square (or 100 in a 15'x15' area, one square in missile scale.) Any character entering the area must roll a successful saving throw vs. paralysis or step on a caltrop, suffering the listed damage. The victim is reduced to ½ movement until he spends a round removing the caltrop from his foot. In addition, the character must make a second saving throw; if he fails, his foot is considered to be *struck* (see Chapter Six) and he is reduced to ½ movement until it heals.

A character moving at half his normal speed or slower can pick his way through the caltrops without trouble—as long as he can see them. A low ground fog or long grass may hide caltrops from even the most observant characters. If a character is running or charging when he steps on a caltrop, he must stop immediately.

Cestus. The cestus is an armored gauntlet equipped with spikes, blades, and other such things. It is worn over the fist and used for punching an opponent. The cestus suffers a -2 penalty to attacks against enemies in any kind of plate armor.

Chain. The chain is simply a weighted length of chain that is whirled rapidly. It is used to strike and tangle an opponent. If the chain is used for a pull/trip maneuver, the attacker gains a +4 bonus on his Strength check. This also applies to pull/trips against riders.

Chakram. The chakram is a throwing quoit or disk with a sharpened outer edge, about a foot in diameter. It is thrown frisbee-style, with a rapid spin. The chakram is not as effective against armored opponents and suffers a -2 penalty to attacks against targets in any kind of mail, scale, or plate armor.

Chijikiri. This composite weapon consists of a spear with a length of chain attached to the butt. It can be wielded as an ordinary spear, or reversed and used to tangle or flail at an enemy. If the chain end is used, the chijikiri is a Type B weapon that inflicts damage as a chain. The chijikiri adds +4 to the attacker's effective Strength for pull/trip maneuvers but cannot be used to pull/trip a rider.

Club. Mankind's oldest weapon exists in thousands of varieties. Clubs range from something as simple as an animal's thigh bone to a well-balanced work of art. Not all clubs can be thrown, but throwing weapons are common enough that a PC can obtain one as easily as a melee-only weapon. Clubs are effectively free, but if a

PC wants to get one that is recognized as a warrior's weapon it may cost anywhere from 5 sp to 10 gp.

Club, great. The great club is simply a two-handed version of the regular club. It is often equipped with nails, spikes, or bands of iron. Its greater size and mass gives it a better damage potential than its smaller forebear.

Crossbow. A crossbow is a short, powerful bow mounted on a rifle-like stock. It is aimed and fired like a rifle. Historically, crossbows were more powerful than bows and had better hitting power at a greater range, but they were also far slower. The English longbow was never decisively bested by the crossbow simply because a trained archer could fire six arrows to the crossbowman's single bolt.

Crossbows were invented sometime in the Dark Ages, but didn't come into widespread use until the Crusades. The earliest crossbows were pellet bows that fired small stones or bullets instead of quarrels. The weapon rapidly grew larger and more powerful. By the Renaissance, many crossbows couldn't be drawn by hand and had to be winched back by a hand-held cranequin.

For game purposes, crossbows are divided into five categories: the pellet bow (the lightest crossbow commonly available), the light crossbow, the heavy crossbow, the cho-ku-no or repeating crossbow, and the hand crossbow. The light crossbow can be cocked by hand, but the heavy crossbow requires the use of an attached cranequin to draw it. The cho-ku-no is similar to a light crossbow, but holds up to 10 bolts in a magazine that rests on top of the weapon. Normally, it is only available in oriental settings. The hand crossbow is derived from the Drow weapon, but could have been built in Renaissance-like settings as a weapon for personal defense or assassination.

To reflect the power of a crossbow, the damage ratings have been increased. Under the *PHB* rules, characters have little reason to ever use a crossbow when a short bow is handy. In addition, crossbows gain a special *armor penetration* ability. At medium range, light and heavy crossbows reduce the AC of an armored opponent by 2 points. (See the pile arrow description under *bow*.) At short range, light and heavy crossbows reduce the AC of an armored opponent by 5 points. Pellet bows, hand crossbows, and cho-ku-no do *not* have this special ability.

Heavy crossbows are also called *arbalests*.

Dagger. Mankind's second oldest weapon is probably the stone dagger. Daggers are short, stabbing

Chapter Seven



blades ranging from six inches to more than a foot in length. Their size and utility have made them a very long-lived weapon used in many times and places.

In Stone Age or savage settings, metal daggers may not be available. Daggers can also be made of sharpened stone or bone. However, weapons of these inferior materials have a 1 in 6 chance of breaking on any successful hit.

Renaissance settings introduce several variations on the common dagger, including the *main-gauche*, *parrying dagger*, and *stiletto*. The *main-gauche* and *parrying dagger* are designed to be used in the off hand of a swordsman armed with a rapier or sabre. Their heavy guards and quillons give the user a special +2 bonus to any attempts to block with the weapon. In addition, the *parrying dagger* may break an enemy's sword when used in a defensive disarm maneuver. If the maneuver succeeds, the attacker must roll a successful saving throw vs. crushing blow for his sword if it is a rapier, or vs. normal blow for any other kind of sword.

The *stiletto* is a long, thin blade designed solely for piercing. It can punch through armor or slip between the links of chainmail. This gives the *stiletto* a special +2 bonus to attacks against armored opponents. (See the note under *pile arrow* or *crossbow*.)

The *jambiya* and *katar* are weapons found in eastern campaigns. The *jambiya* is the traditional Arab dagger, with a sharply curved blade. It is often ornately decorated. The *katar* is a dagger with an 'H' handle, designed to be held in a closed fist with the blade projecting out over the knuckles. It is used with a punching motion.

Dart. These weapons are not the tiny modern darts you may be familiar with. They're much larger and heavier than their sporting counterparts. Darts were usually as large as a typical arrow, with a weighted head. They were popular among ancient peoples and eastern cultures, and were used as small javelins by skirmishers and light cavalry.

Firearms. Guns are completely optional in the AD&D game. If the DM rules that they are not available in his campaign, no character may take proficiency in a firearm or purchase one. Like many weapons, firearms gradually improved over time, increasing in reliability, range, and firepower.

Firearms have several unusual characteristics. First of all, they are subject to misfires. Modern tests have shown that primitive firearms probably misfired as often as once every four shots. When a character's attack roll falls in the misfire range, the DM should roll 2d6 and consult the following table:

2d6	Misfire Result
2-3	Explosion
4-7	Fouled barrel
8-12	Hangfire

An *explosion* inflicts 2d6 points of damage on the character holding the gun, or 1d6 if a saving throw vs. death is successful. The gun is destroyed by the misfire. A *fouled barrel* ruins the shot and renders the gun useless until it is carefully cleaned—a process that will take a good 10–30 (1d3×10) minutes. A *hangfire* goes off 1d3 combat rounds later than it should. If the user keeps the gun trained on its target, he can make a normal attack.

The second unusual characteristic of firearms is their ability to ignore armor. Any firearm except a hand match weapon may ignore the portion of a target's AC that is derived from physical armor or shield. At short range, Dexterity, cover, and magical bonuses are the only factors that contribute to a target's AC. At medium range, the target's base AC is penalized by 5 (which may be as bad as ignoring it altogether), and at long range, the base AC is penalized by 2.

For example, a renegade knight in plate mail +3 is fired upon by the king's musketeers. Normally, his AC is a base 0. A short-range musket shot ignores the 7-point AC reduction provided by plate mail, and only the armor's +3 enchantment is considered. The renegade knight's AC is a 7. At medium range, the armor is not completely ignored, but the base AC of 3 is reduced to an AC of 8. Magic adjusts this to AC 5. At long range, the knight is AC 2 against musket fire.

Last but not least is the ability of a firearm to cause open-ended damage. Any time a firearm hits its target, there is a 25% chance that a second damage die is rolled and added to the first. There's a 25% chance that *that* damage roll creates additional damage, and so on. This 25% chance is part of the knockdown die roll; if the knockdown die comes up 7 or better, the damage continues.

For example, Sir Vandegar is shot by an uncouth man-at-arms wielding a horse pistol. The damage roll comes up a 3, but the knockdown die is an 8. A second damage die is rolled, which results in 5 more points of damage. Vandegar's attacker rolls another knockdown die, which comes up 7, so he rolls a third damage die, getting a 6. Fortunately, he misses on his

Weapons & Armor



chance to do any more damage, but Sir Vandegar suffers a total of 14 points from a single bullet.

The very earliest firearms were *hand match* devices that resembled a hand-held bombard. Hand match weapons include the handgunne and the arquebus. Unlike other guns, hand match weapons have no triggers or firing mechanisms. Instead, the user touches a burning slow match to a hole in the barrel, igniting the weapon's charge. The handgunne doesn't even fire a bullet, but propels a heavy iron arrow that cannot cause continuing damage like other firearms. All hand match weapons suffer *double* the normal range penalties for medium and long-range shots.

The *matchlock* was a significant improvement. It freed one of the user's hands by providing a clamp to hold the slow match, and provided a trigger mechanism that would bring the match into contact with the priming powder. The matchlock arquebus is a far more powerful and reliable weapon than the hand match version. Matchlocks were also made as calivers and muskets. The caliver was a smaller weapon that fired a lighter bullet. The matchlock musket was a long, heavy weapon that had to be fired from a forked rest or balanced on a wall.

Wheellocks were the next improvement to the firearm. Instead of a burning match, the powder was ignited by sparks provided by a spring-driven wheel of flint. It worked a lot like a modern cigarette lighter. Wheellocks were contemporaries of snaplocks, which held a single piece of flint in a hammer-like striker. The snaplock was easier to manufacture, but less reliable, so wheellocks were often the weapon of the nobility and anyone else who could afford to spend more money on a gun. The wheellock arquebus was a light but powerful weapon reserved for use by the wealthy or the privileged. Interestingly enough, wheellocks were never developed outside of Europe.

Pistols were also introduced as wheellocks but were also manufactured as snaplocks. At first, pistols were the weapon of the cavalry. The horse pistol replaced the lance as the weapon of choice for horsemen. Most cavalymen carried two or three of these heavy pistols for dealing with pikemen and other such annoyances. In time, belt pistols were produced as lighter versions of the horse pistol for personal defense.

Flintlocks were the direct descendants of snaplocks. They are almost indistinguishable from each other, but the later flintlocks tended to be sturdier and more reliable than their predecessors. Flintlocks saw the introduction of the carbine, or horseman's musket, which

was a lighter weapon than the infantryman's gun. By the time flintlocks had been invented, muskets no longer required a rest for their barrels and could be fired from the shoulder.

The blunderbuss was the ancestor of the modern shotgun. It was a short, musket-like weapon with a bell-shaped, flaring muzzle. Just about anything could be poured into the barrel of a blunderbuss and then fired at an enemy—stones, nails, coins, or even salt or gravel. At short range, a blunderbuss actually inflicts 1d4 separate attacks on its target, but none of the projectiles are heavy enough to inflict the extra damage of other firearms. At medium range, the blunderbuss makes a single attack on 1d3 separate targets in a 3-foot radius (or one square.) At long range, the blunderbuss inflicts 0–1 (1d2–1) attacks on any targets in a 5-foot radius (four squares.) A lucky blunderbuss shot can knock down four or five attackers at once, or it may only make a big noise and miss everything.

Combined weapons are an interesting side-note in the history of firearms. When firearms were still relatively new, it was fairly common to make sure that the weapon retained its usefulness after its first shot by building a melee weapon around it. Hammers, axes, broadswords, and daggers were all made with parallel gun barrels. In some cases, the barrel actually served as the weapon's haft. The numbers listed on the table reflect the weapon's stats as a melee weapon; otherwise, it is treated as a wheellock belt pistol.

Flail. Developed from the farmer's threshing tool, flails were used on battlefields throughout the Middle Ages. The common grain flail can be found on the Tools list, since nearly every farm has several around. The horseman's flail is similar, but uses iron weights and replaces the linking rope with sturdy chain. The horseman's flail gains a +1 bonus on attacks against targets using shields, since it can easily strike around them. In addition, horseman's flails gain a +2 bonus on any attempts to trap or offensively disarm an opponent's weapon.

The footman's flail is a different weapon entirely. It consists of a sturdy shaft with a hinged (not chain-joined!) iron-spiked head. It is used with two hands and can deliver crushing blows of great power. The footman's flail gains a special +1 attack bonus against opponents in any kind of plate armor.

Fork. The common pitchfork has been adopted as a ready means of defense by farmers throughout the ages. Almost any farm or town has a plentiful supply of forks.

Chapter Seven



Gaff/hook. The gaff is a short, T-handled hook used to boat fish or handle heavy crates. For 5 gp, a hook can be attached in place of a missing hand, which provides a character with a weapon that cannot be disarmed.

Grapple. Grapples are often used at sea and in sieges. Usually, they are made from three or four iron hooks welded together and a sturdy length of rope. Grapples can be thrown 5 feet horizontally or 3 feet vertically per point of Strength. Although grapples aren't intended for personal combat, a creative character can improvise a number of pull/trip maneuvers with a grapple and length of rope.

Gunsen. This deceptive weapon resembles an oriental fan. It is both a parrying device and an effective bludgeon. The paper fan contained in a gunsen is used to distract and confuse an opponent, and is often decorated with beautiful designs. A character proficient in the gunsen's use gains a special +2 bonus to any block maneuvers she makes with the fan.

Hammer. Used in almost any craftsman's trade, hammers can be found in shops and worksheds everywhere. Most working hammers are much smaller and lighter than any military versions.

Hand or throwing axe. Variations on the medium-sized axe exist in almost any setting. Not every hand axe can be thrown; the weapon must be built for balance to be thrown, although this isn't particularly rare or unusual. The Franks made excellent use of throwing axes as a shock weapon; the Frankish line would halt just short of the enemy and hurl a murderous volley of axes before closing for hand-to-hand fighting. With a called shot, an axe can be thrown at an enemy's shield, which must then roll a successful saving throw vs. normal blow or be ruined.

Harpoon. Rarely used on the battlefield, the harpoon is the weapon of sealers and whalers throughout the world. The head of a harpoon is hinged to lodge in a wound and fix the harpoon to its target. A roll of 5 or better on the knockdown die indicates that the harpoon is stuck in the victim, and will cause an additional 1d6 damage if it is yanked out or cut out of the wound.

Usually, a strong line is attached to the harpoon so that the hunter can keep hold of his prey after striking with the weapon. If the head is stuck, the wielder can engage in an opposed Strength contest with the target to pull him off his feet. When harpoons are used against large creatures, the cord is usually tied off to the hunter's boat, which helps the hunter's Strength check considerably.

Hatchet. Many smaller hand axes actually fall into this category. The hatchet's small size permits it to be used as an off-hand weapon. Hatchets are also handy tools for wilderness travelers or people who work with wood.

Holy symbol. Only the most impressive personal holy symbols are large enough to be wielded as bludgeons. If a creature is subject to damage from coming into contact with a holy symbol, this is in addition to the bludgeoning damage inflicted by the weight of the blow. Of course, if a creature is only hit by magical weapons, then the holy symbol must be enchanted to inflict bludgeoning damage.

Javelin. Light throwing spears have been used in warfare and hunting for thousands of years. By the time of the Crusades, javelins are generally found in the hands of nonWestern cultures; they lack the penetrating power to be effective against heavy Western armor.

Jitte. The jitte is an iron parrying bar with a short hook at one end. It isn't sharp, but can be used to strike bludgeoning blows. The jitte provides a special +2 bonus to block or defensive disarm maneuvers.

Kama. This weapon is a straight-bladed sickle derived from the common peasant's tool. Since it is regarded as a tool, it can be carried by a character who wishes to conceal the fact that he is armed.

Kau sin ke. The kau sin ke, or whipping chain, is an oriental version of the flail. It consists of four to six iron bars linked end-to-end by short lengths of chain. The kau sin ke gains a special +1 bonus to attack rolls against opponents using shields, since it can strike around the shield.

Kawanaga. This weapon consists of a grapple with a weighted rope attached. The hook or weight can be used to strike at opponents, and the grapple is handy for climbing as well. The kawanaga adds +4 to the attacker's effective Strength when used to perform the pull/trip maneuver.

Knife. Perhaps the most common weapon is the humble knife. Almost everyone carries small knives for eating, as an all-purpose tool, or for personal defense. Knives are shorter than daggers and are used to both slash and stab. They can be easily concealed in a variety of specialty sheaths, ranging from a dandy's hatband to spring-loaded wrist sheaths. Bone and stone knives can be manufactured in settings where iron and steel are unavailable.

Kusari-gama. The kusari-gama consists of a kama, or sickle, with an attached length of chain. It is extremely versatile and can be employed in a number

Weapons & Armor



of ways. Like several other chain weapons, it adds a +4 bonus to the attacker's Strength checks when used to perform the pull/trip attack option.

Lance. The lance is the horseman's spear. It has been used in warfare since the Bronze Age. Prior to the invention of the stirrup, the lance could not be couched for a charge; instead, the horseman would stab overhand with the weapon or even throw it. As a rule of thumb, a rider must be mounted on a horse appropriate for his lance, or else his weapon will be reduced in effectiveness. A heavy lance requires a heavy warhorse, a medium lance requires a medium warhorse, and so on. If the lance is too heavy for the horse, it does damage as if it were the correct type, so a heavy lance used from a light warhorse does damage as a light lance.

Generally, the heavy warhorse was a European development that appeared in the later stages of the Crusades. Before the development of heavy plate armor, it wasn't necessary to use draft horses for mounts.

Lances are an exception to the size requirement rules; a rider with stirrups can use any lance in one hand, but a rider without stirrups has to use two hands for the lance. (Stirrups appeared during the Dark Ages in Western Europe.) As noted above, a rider with stirrups can couch the lance for a mounted charge, which causes double damage.

In addition to the light, medium, and heavy lances, Late Middle Ages campaigns will also see the use of the jousting lance. This weapon is blunted to prevent its target from being severely injured during a tournament.

Lantern. On occasion, a character has to make do with whatever's handy. A lantern can be used as a crude club, inflicting light damage, but if it is lit it may spill burning oil over the defender. Roll an item saving throw for glass against a normal blow; if the lantern breaks, the victim is burned for an additional 1d4 points of damage and may be on fire. See *oil*.

Lasso. The lasso, or lariat, is commonly associated with nomadic cultures. Native Americans and Central Asians commonly used the lasso on animals, and it was only rarely used against an enemy. Lassoes are only effective when used in conjunction with a called shot attack; they cannot be used for normal attacks.

If the attacker succeeds with a called shot against his opponent's legs, he gets the lasso to settle low enough on his opponent's body that he can pull/trip his enemy. He gains a special +4 bonus to his opposed Strength check. If the attacker is mounted and has the lasso made fast to his saddle, he is considered to be the size

of his mount—so a rider on horseback is size L for purposes of the opposed Strength check, for a total of +8 versus Man-sized targets.

If the attacker succeeds with a called shot against his opponent's arms, he can trap his enemy's weapon, shield, or both by pinning his arms to his body. The lasso user's opposed attack roll is made against AC 10 instead of AC 2. If the attacker wins the roll, one arm (randomly determined) of the defender is trapped. If he beats him by 4 or more, both arms are trapped. In addition, if the attacker is mounted and the lasso is tied off to the saddle, he can perform a pull/trip next round without an attack roll simply by spurring his horse.

Last but not least, a lasso can unhorse a rider by succeeding in a called shot. If the rider is moving and the lasso is tied off to something solid (like a tree), he is automatically unhorsed. If the rider isn't moving or the lasso isn't tied off, an opposed Strength check is used to determine whether or not the rider is unhorsed.

Mace, horseman's. The mace is another ancient weapon that remained in use until the 19th century in many parts of the world. The horseman's mace is lighter and shorter than the footman's for ease of use from horseback. Most horseman's maces are constructed from four to eight iron flanges. The horseman's mace receives a +1 bonus to attacks against opponents in any kind of mail armor.

Some horseman's maces of Middle Eastern or Oriental origin feature sword-like basket hilts. The hilt provides a +1 bonus to attempts to block attacks with the weapon.

Mace, footman's. The footman's mace is a hafted weapon with a heavy iron or bronze head. The head can be spherical or flanged, and may feature spikes or knobs. Like its smaller cousin, the footman's mace is especially useful against flexible armors and receives a +2 bonus to attacks against enemies in mail of any kind.

Mace-axe. This Bronze Age weapon features a mace-like head with a single curving axe blade projecting from it. It is heavy and awkward, but delivers a formidable blow.

Machete. The machete is regarded as a tool by some cultures, and as a weapon of war by others. It consists of a short, heavy, slightly curved blade designed for slashing. Many varieties of tribal swords or fighting knives fall into the category of machetes, and may be elaborately decorated blades of superior construction and balance. In eastern lands, these blades are known as *parangs*.

Chapter Seven



Mancatcher. The mancatcher is a short pole-arm with two curving, fork-like prongs at the business end. The prongs are hinged so that they can be pushed tightly closed around the intended captive. The mancatcher only works against Size M creatures. Like crossbows and firearms, mancatchers ignore armor—only Dexterity and magical adjustments apply. If a hit is scored, the victim suffers the listed damage. Each round, the mancatcher's user can push and pull the victim about for an automatic 1d2 points of damage, and can try to pull/trip his victim by succeeding in an opposed Strength check.

Once caught, the victim loses all Dexterity and shield adjustments to AC. He can only escape by hacking through the weapon's haft (AC 4, 10 hp, size M type S weapon to damage) or making a bend bars/lift gates roll, which causes an additional 1d2 damage.

Mancatchers are used by town watches and gendarmes to capture armed criminals.

Maul. The maul is a military sledgehammer designed for two-handed use. It is about three to four feet in length with a heavy square head. It receives a +1 bonus to attacks against opponents in plate or mail armors. Traditionally, the maul was carried by lightly armored troops such as archers for use against dismounted knights.

Morningstar. Also known as the godentag or holy water sprinkler, the morningstar is a hafted weapon three to five feet in length with a heavy, spiked head. It is designed for two-handed use and often features a polearm-like spike at its end. Like the maul, the morningstar was built to penetrate a knight's armor. It receives a +1 bonus to attack rolls against any type of plate armor.

Net. Rarely used as a weapon, the net is only found in unusual settings. A fighting net often features small barbs or weights in the weave and a trailing rope for guidance and control over netted targets. The net's only function in hand-to-hand combat is to block, trap, or disarm an opponent; it cannot strike effectively for damage.

The net is most dangerous when it is thrown at an enemy. Only the target's Dexterity and magical adjustments to Armor Class count. If the net hits, it may trap the opponent's weapon and shield. If the victim is trapped, he can only break free by making a Strength check. In future rounds the net user has the choice of leaving the net where it is and attacking with another weapon or of trying to improve the capture.

To improve the net's capture, the netter loops the

trailing rope around the target. This requires another attack roll (as before, only count Dexterity and magic.) If the netter hits, the victim's effective Strength drops by 4 for purposes of getting out of the net.

Nets must be folded properly to be effectively thrown. The first time a character throws his net in a fight, he makes a normal attack roll. After the net is unfolded, it can only be thrown with a -4 penalty to hit. It takes 2 combat rounds for a proficient user to fold a net.

Nunchaku. The nunchuks consist of two wooden or iron bars linked by a small length of chain. Like the western flail, they are descendants of the common grain flail. A proficient user may wield nunchaku in each hand, despite the fact that they are identical in size—but the attack penalties for attacking with two weapons still apply.

Oil. Burning oil can be an effective weapon in some situations. There are three basic uses for oil: igniting a puddle under an enemy's feet, throwing or splashing burning oil on him, or making a Molotov cocktail.

If an enemy can be lured into a place where oil in contact with him can be ignited, he suffers 1d4 points of damage per two flasks that have been prepared for firing. The victim must attempt a saving throw roll vs. paralysis or *catch fire*—see below. There is no attack roll for this type of attack, but if the oil has to be ignited by a burning arrow or thrown torch, the DM can insist that an attack roll versus AC 10 be made to get the fire to the oil.

Throwing burning oil at a target is difficult. This category is reserved for things like busting a burning lantern over someone's head or dumping a bowl on the intended victim. The victim suffers 1d3 points of damage per flask thrown and must make a saving throw vs. paralysis with a +4 bonus or *catch fire*. An attack roll is required for this type of attack, but only the defender's Dexterity and magical adjustments are considered for AC.

A Molotov cocktail requires a full combat round to fuse and light, so one can be thrown only once per two rounds. As above, an attack roll is required; only count the defender's Dexterity and magical adjustments. If struck, the defender gets to roll a saving throw vs. death to see if the cocktail went off or not; if it does, the victim suffers 1d8 points of damage and must roll a successful saving throw vs. paralysis or *catch fire*.

Victims who catch fire suffer 1d4 points of damage in the round following their unfortunate change of status. They are allowed to roll a saving throw vs. death to

Weapons & Armor



extinguish the flames each round; if they fail, the base damage is increased by 1 die. Therefore, a character who is on fire suffers 1d4 points of damage the first round, 2d4 the second, 3d4 the third, and so on, to a maximum of 5d4 per round. Leaping into a lake, extinguishing the flames magically, or rolling around on the ground may allow the character to roll his saving throw with a +2 to +8 bonus, at the DM's discretion.

Parang. See *machete*.

Pick. This common tool can be used as a weapon but is very heavy and unwieldy.

Pick, horseman's. The military version of the stonemason's tool features a short, beaked spike designed for punching through heavy armor. The horseman's pick has a +1 bonus to attacks against opponents in plate armor of any type. Many picks are equipped with a hammer or axe blade on the reverse side of the head, and may be P/B or P/S type weapons for a small cost increase.

Pick, footman's. A larger and heavier version of the horseman's pick, the footman's pick gains a +2 bonus versus plate armors.

Pilum. The famous javelin of the Roman legionaries, the pilum is forged with a long, soft iron head. When a thrown pilum hits a shielded opponent or misses by only one or two points, it sticks in the shield. The weapon's weight bends the soft iron head and makes the shield unusable until the pilum is removed—a process that requires 1d6 combat rounds. Magical shields have a 20% chance per plus of ignoring the pilum's effects.

Polearm. Polearms are long, hafted weapons designed for two-handed use. Hundreds of varieties exist, each with its own specialized function. In the Middle Ages, polearms were introduced to give the foot soldier a weapon capable of dealing with the heavily armored knight. They are more common on the battlefield than in adventuring parties.

The first type of polearm are the spearlike weapons. These are primarily thrusting weapons and are especially effective when set against charges. The pike is a very long weapon with a small iron head; the ranseur, spetum, and partisan are shorter weapons with side blades or spikes that give the user a +2 bonus on any trap or block attempts. Partisans survived into the 19th century as ceremonial weapons.

The next category of polearm are the *pole axes*. These are heavy weapons with axe-like heads that are designed for maximum striking power. Poleaxes include the bardiche, the halberd, and the voulge or Lochaber

axe. Poleaxes gain a +2 bonus on attack rolls against any type of plate or mail armor.

Glaives are simple polearms that consist of a single long, curving blade used for both slashing and thrusting. They lack the cutting power or strong straight point of poleaxes or spearlike weapons, and are generally not as effective as the previous weapons. Glaives include the glaive (naturally), the fauchard, and the oriental nagimaki and naginata. As a side note, the nagimaki is actually a horseman's weapon.

Bills are multi-function polearms that include a cutting surface, a spearlike spike, and hooks or curved blades on the back for dismounting riders. Bills, bill-guisarmes, glaive-guisarmes, and guisarmes all fall into this category. All of these weapons provide a +2 bonus to pull/trip attempts against riders.

The last category of polearms are weapons without a true category. These specialized weapons can't be classified as one of the above types. The bec de corbin, or crow's beak, is a weapon designed to pierce heavy armor; it gains a +3 bonus to attacks versus any kind of plate armor. The Lucern hammer is similar, but uses a clawed hammer head instead of a single beak. It gains a +2 bonus to attacks versus targets in plate armor. The military fork is nothing more than a war version of the peasant's pitchfork.

Last but not least, two oriental polearms fall into this catch-all category. The lajatang is an unusual weapon with half-moon blades at either end; a proficient user Threatens his flank spaces as well as his front squares. The tetsubo is a kind of pole-mace with a heavy, iron-bound head.

Pry bar. Generally, a pry bar is a weapon of convenience, not choice. It can be used as an effective bludgeon.

Quarterstaff. The staff is the favored weapon of travellers and peasants everywhere. Its iron-shod ends are used to strike powerful blows or jab at an enemy. The oriental bo stick resembles the quarterstaff in length and balance, but is used differently. The quarterstaff suffers a -2 penalty to attacks against plate armor.

Sai. The sai is a parrying weapon with a large crossguard. It resembles a dagger, but the "blade" is round with no edges. It is normally used for bludgeoning attacks. The sai's crossguard provides a +2 bonus to any block, trap, or disarm attempts.

Sang kauw. This weapon resembles a short, double-ended spear with a buckler or bladed guard at the center. It requires both hands but provides a proficient user with an AC bonus of +1 due to the small

Chapter Seven

shield. Like the lajatang, the sang kauw threatens both of the wielder's flank squares as well as his front spaces.

Sap. The sap is a leather bag filled with sand or lead shot. It is used to render an unsuspecting victim unconscious. Saps are only effective when used against opponents in leather or lighter armors. To go for an instant knockout, the user must make a called shot to the target's head. If he hits, there is a 5% (40% chance maximum) chance per point of damage that the victim is knocked out for 3d10 rounds. A target wearing a helm of any kind provides the attacker with an additional -4 penalty in addition to the called shot penalty. A creature of size Large or greater cannot be knocked out this way. See Chapter Two for more information on sapping.

Scourge. The scourge is a torturer's weapon. It consists of a handle with several leather whips, often studded with barbs, nails, or other similar devices. The scourge's whips can catch and grab an enemy's weapon, and the wielder of the scourge gains a +1 bonus on any disarm attempts.

Scythe. Another tool converted into a weapon, the scythe mounts a curving blade perpendicular to a long wooden haft. It was originally intended to be used for harvesting grain, and is slow and awkward as a weapon.

Shuriken. Also known as *shaken* or *throwing stars*, shuriken come in a variety of shapes and sizes. The most common designs are large throwing needles and flat, star-shaped blades. Shuriken are the favored weapons of assassins in oriental campaigns.

Sickle. Like the scythe, the sickle is primarily a tool

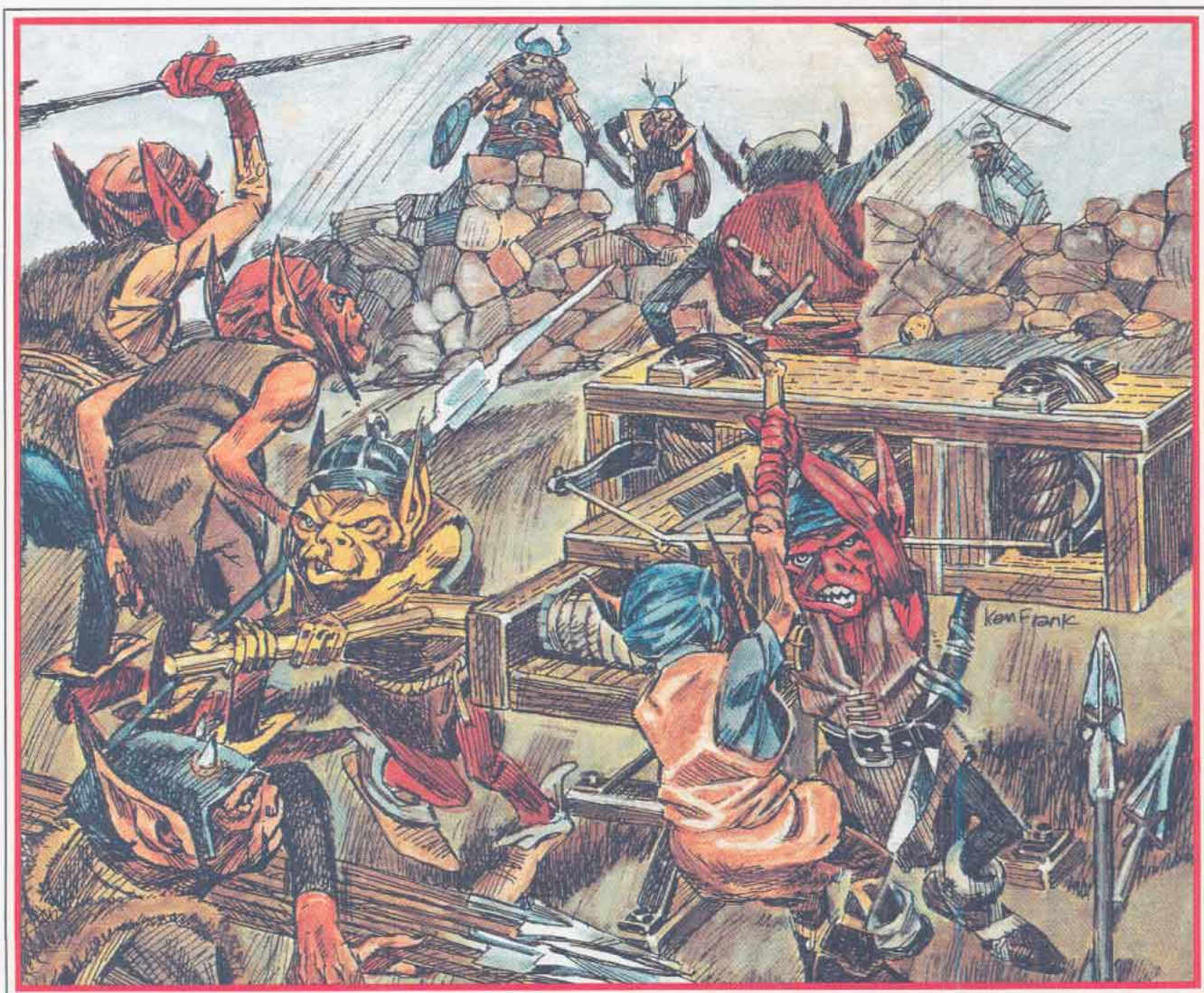

Weapons & Armor



that occasionally sees use as a weapon. The sickle's curving blade is used for cutting crops for harvest, and priests of nature or agriculture often use the sickle as a ceremonial weapon.

Sledge hammer. Sledges are used in construction and masonry work of all kinds. It is generally too heavy and slow to be used as a weapon except in an emergency.

Sling. One of the most common missile weapons is the humble sling. This is not a child's toy slingshot; this is a weapon that can hurl small stones or lead bullets with lethal force. The sling is a simple length of cord or cloth with a cup in the center. The projectile is placed in the cup, and the sling is whirled rapidly in a sidearm or overhead motion. Slings can be improvised from many materials, and are among the cheapest of weapons.

Slingstones can be found in any rocky landscape. Normally, small round rocks are best, such as the type found in streambeds. Sling bullets are made of lead, bronze, or iron, much like the bullets for a firearm.

Spade. Shovels or spades can be used as a weapon of last resort if there is nothing more warlike at hand. Folding military spades with sharpened blades were used in hand-to-hand fighting in both World Wars.

Spear. The spear is one of mankind's oldest weapons. Literally thousands of variations exist, but they all feature a head designed for stabbing or thrusting. Throughout the Bronze Age and the years of the Roman Empire, the spear was the most common weapon on the battlefield. In primitive settings, stone-headed spears are common. The spear can be used either one-handed or two-handed.

Spear, long. The long spear is nothing more than a heavier spear with a longer reach. A normal spear ranges from 5–8 feet in length, but a long spear is about 10–12 feet long. The longest weapon of this family is the pike, which was often 18–21 feet in length. The long spear is a two-handed weapon.

Staff sling. The staff sling simply consists of a short wooden staff with a leather sling at one end. It can be used to throw larger and heavier projectiles than a normal sling, but can't throw them as far or as accurately. The sling has no short range category; instead, any shot from 0–12 squares away is considered a medium range shot.

In addition to throwing stones, staff slings can also be used to throw *stinkpots*—small clay vessels filled with noxious burning materials. If a stinkpot misses its target, it still scatters and breaks open (see Grenade-like missiles in the *DMG*.) Any character within one

square of a stinkpot hit must roll a successful saving throw vs. death or suffer a –2 penalty to all attacks due to choking and coughing for 1d6 combat rounds.

Sword. Swords are the most efficient weapons of ancient times, combining ease of use with excellent armor penetration. The earliest copper swords appeared thousands of years before the rise of the Roman Empire, and ceremonial swords are carried today by most of the world's armies and navies.

Bastard swords are also known as hand-and-a-half swords. They are nothing more than longer, heavier long swords. The extra weight of a bigger blade enabled the sword's wielder to hack through the heavier armor that appeared at the end of the Crusades. Whether used one-handed or two-handed, the bastard sword gains a +1 bonus to hit opponents in any type of mail or plate armor.

Broadswords have existed in a number of settings. Any medium-sized blade designed for slashing can be called a broadsword. In ancient times, the best blades fall into this category; by the Middle Ages, this describes a civilian's sword or a court blade. Later broadswords were built with basket hilts, which give the weapon user a +1 bonus on any block attempts.

The claymore is a Scottish two-handed sword somewhat shorter than the true two-handed sword. It is an excellently balanced weapon with fearsome cutting power. The claymore gains a +1 bonus to hit opponents in any kind of leather, mail, or plate armor.

The cutlass is a heavy, slightly curved, single-edged blade of medium length. It was popular with sailors and marines for hundreds of years. Like some broadswords, cutlasses were made with basket hilts.

The drusus is a Roman short sword of exceptional quality. It's really nothing more than a well-made gladius kept at a razor-honed edge. The weapon's fine quality provides a +1 bonus to attack rolls, but after any fight the weapon is considered to be dulled and functions as a normal gladius until it is re-honed—a task that requires a fully-equipped forge and a trained swordsmith.

The estoc is the grandfather of the rapier. It is an edgeless thrusting sword designed for piercing armor. It gains a +2 bonus to attacks against opponents in any kind of mail, and a +1 bonus to attacks against opponents in any kind of plate armor. Estocs were often made with perfectly triangular or square blades.

The falchion is a slashing weapon with a slightly curved blade and a squared-off point. It is nearly useless for thrusting, but its blade design concentrates the

Chapter Seven

weight of the blade near the end for excellent chopping power.

The traditional weapon of the Roman legionary was the gladius. It is basically a well-made iron or steel short sword used almost exclusively for thrusting.

The samurai's katana may be the single finest sword ever made. It is a slashing weapon with a sharp, chisel-shaped point. The steel was often of exceptional quality, built up with a laborious process of folding and re-folding; some blades had hundreds of folds. This created a sword of tremendous resilience and strength. The hilt accommodates one or two hands equally well.

The companion to the samurai's katana is the wakizashi, a shorter blade of similar construction and design. In eastern cultures, only a samurai may wear these two blades together. It is very common for a katana and wakizashi to be paired as a matched set.

The khopesh is an ancient weapon of the Bronze Age. Its blade runs straight from the hilt, but then curves around in a great sickle shape. It is heavy and awkward, but may be the only sword available in some settings.

The long sword is meant to represent the weapon of the typical western knight, but also includes any medium-length straight blade designed for both slashing and thrusting. The advent of heavy plate armor made the long sword obsolete; longer, heavier blades were required to pierce a knight's armor.

Just as the samurai has his traditional katana, the ninja has his ninja-to, the traditional sword of the assassin. The ninja-to is smaller than the katana and generally not as well made. Unlike the katana, the ninja-to features a larger guard and a sturdy scabbard which can be used as a climbing step.

The largest oriental sword is the no-dachi, a two-handed katana-like weapon almost six feet in length. Some no-dachi are built to the exacting specifications of a katana, but most are not of the same quality.

One of the later swords to appear was the rapier, a light, long thrusting weapon. The rapier was the gentleman's weapon in the Renaissance and later centuries, remaining in use until the 18th century. The rapier appeared largely because armor was beginning to disappear from the battlefields of Europe.

Another duelist's weapon is the sabre, a slightly curved slashing blade of medium length. The sabre had one of the longest periods of service of any sword; they appeared in Europe during the 11th century, and were still considered standard issue for cavalrymen at the beginning of the 20th century.

The most ancient sword in this listing is the sapara, a weapon of the Mesopotamian empires of the Bronze Age. The sapara is a smaller version of the khopesh, and is no larger than a standard short sword.

One of the most distinctive swords is the scimitar, a gracefully curved weapon favored by many Arabian cultures. The scimitar was carried by Muslim warriors from Spain to India and became a symbol of the strength and subtlety of Islam. The great scimitar, a two-handed version of the normal blade, was a weapon reserved for ceremonial guards and elite palace troops.

By far the most common blade is the humble short sword. Thousands of varieties have been created by nearly every culture on Earth. Regardless of the setting, some equivalent to the standard short sword can be found. The short sword is primarily a thrusting weapon, ranging from 1½ to 2½ feet in length.

The spatha is the ancestor of most Western European blades. It is the Roman long sword, a weapon developed for Roman cavalry but soon copied by the barbarians who fought against the Romans.

The sword-axe is not a true sword. It features a long wooden haft in place of a hilt, and a sword blade with an axe-like construction at the business end. In battle, it would be wielded more like an axe than a sword. It was a weapon of ancient times that was soon replaced by more efficient blades.

The tulwar bears a small resemblance to the falchion, but is found in eastern settings. Unlike the falchion, the tulwar curves inward for chopping power, instead of outward for a longer slash. The famous Ghurka knife is a good example of a tulwar-like blade.

The largest and most powerful sword is the two-handed sword, or *zweihander*. It was developed in the Renaissance to deal with pikemen and dismounted knights. It often stood well over six feet tall. The two-handed sword gains a +2 bonus to attacks against opponents in any kind of mail or plate armor, since its heavy blade can easily penetrate even the heaviest armor.

Three-piece rod. It is said this weapon was invented by a master of the martial arts whose staff had been broken by his enemy. The three-piece rod consists of three short wooden staves, linked by rope or chain. It is exceptionally useful for performing traps, blocks, and defensive disarms; the three-piece rod confers a +4 bonus to any such attempts.

Throwing knife. This terrifying weapon resembles a sword with three or four points. The handle and lower part of the blade appear normal, but the blade forks

Weapons & Armor



several times into a number of dagger-like points. It's thrown horizontally, so that it spins parallel to the ground. The throwing knife is usually considered a weapon of savage cultures.

Torch. Most torches can be used as serviceable clubs in a pinch. If the torch is burning, it inflicts 1 extra point of damage. In addition, most animals fear open flame and may avoid a character waving a burning torch around. Torches only ignite very flammable substances, so normal clothes and the like won't usually be set afire by a single blow from a lit torch.

Trident. The trident is the famous three-pronged spear of seafarers and mercreatures. Fishermen of many cultures use tridents as hunting weapons, but military tridents are much more scarce.

Two-handed axe. This mighty weapon consists of a four- to five-foot haft with a very heavy blade. The axe may be double-bitted, with blades on both sides of the haft, or it may only have a single blade. It is an unwieldy weapon, but a skilled warrior can strike blows of tremendous strength with it.

Vial. Vials aren't particularly damaging by themselves, but when filled with acid or holy water they're somewhat more dangerous. When a vial is thrown at an opponent, the attacker may ignore armor—only Dexterity and magical adjustments to AC count for the defender. If the vial hits, the victim suffers the full damage of whatever substance is inside. If it misses, it may still inflict damage with a splash hit depending on where it lands (see Grenade-like Missiles in the *DMG*.)

War club. The war club is considered a work of art in many cultures. It is carefully built from the best materials available and often lined with sharp stones or spikes to increase its damage potential. War clubs cannot be thrown.

Warhammer. The warhammer is very similar in size and balance to the horseman's pick, but instead of a point for piercing armor the warhammer is equipped with a blunt striking head. The warhammer gains a +1 bonus to attacks versus plate armors.

Whip. The whip cannot cause damage to an opponent in any kind of plate, mail, or leather armors but can still be used to perform a number of special maneuvers. It gains a +2 bonus to pull/trip and offensive disarm maneuvers. In addition, the sting of the lash may force normal animals to retreat at the DM's discretion.

Weapon Groups

As noted in previous chapters, weapons can be classified into *tight* and *broad* groups. All weapons in a tight group are considered to be related to one another; a character proficient in one automatically has familiarity with the rest. Note that a weapon proficiency includes stone or bone versions of the same weapon.

In the listing below, broad groups are noted under the red bold type, and tight groups are in italics.

Axes, Picks, and Hammers

Axes: battle axe, hand/throwing axe, hatchet, two-handed axe, sword-axe, mace-axe

Picks: horseman's pick, footman's pick, pick

Hammers: warhammer, maul, sledge

Unrelated: adze

Bows: short bow, composite short bow, long bow, composite long bow

Clubs, Maces, and Flails

Maces: footman's mace, horseman's mace, mace-axe

Clubs: club, great club, war club, ankus, morning star

Flails: horseman's flail, footman's flail

Crossbows: hand crossbow, light crossbow, heavy crossbow, pellet bow, cho-ku-no

Daggers & Knives: dagger, stiletto, jambiya, main-gauche, parrying dagger, knife, katar

Lances: Light, medium, heavy, jousting

Polearms

Spear-like polearms: awl pike, partisan, ranseur, speutum

Poleaxes: bardiche, halberd, voulgé

Bills: bill, bill-guisarme, glaive-guisarme, guisarme-voulgé, hook fauchard

Glaives: glaive, fauchard, naginata, nagimaki, fauchard-fork

Beaked: bec de corbin, lucern hammer

Unrelated: military fork, tetsubo, lajatang

Spears & Javelins

Spears: spear, long spear, awl pike

Javelins: javelin, pilum, dart

Unrelated: harpoon, trident, brandistock

Chapter Seven

Swords

Ancient: broadsword, sapara, khopesh, sword-axe, short sword

Roman: broadsword, drusus, gladius, spatha

Middle Eastern: short sword, scimitar, great scimitar, tulwar

Oriental: cutlass, katana, wakizashi, no-dachi, ninja-to

Short: short sword, gladius, drusus, sapara, dagger, tulwar

Medium: broadsword, long sword, cutlass, sabre, falchion, estoc

Large: bastard sword, claymore, two-handed sword, great scimitar, no-dachi

Fencing weapons: rapier, sabre, main-gauche, parrying dagger

Chain & Rope Weapons: chain, kau sin ke, kusari-gama, kawanaga, chijikiri

Martial Arts Weapons: sai, jitte, nunchaku, sang kauw, three-piece rod, bo stick

Firearms

Hand match weapons: arquebus, hand gunne

Matchlocks: arquebus, caliver, musket

Wheellocks: arquebus, belt pistol, horse pistol

Snaplocks and Flintlocks: musket, belt pistol, horse pistol

If a weapon does not appear in the preceding listings, it belongs to no weapon group. For example, weapons such as the bolas, the boomerang, or the mancatcher are so unique in their employment that nothing even comes close to being similar.

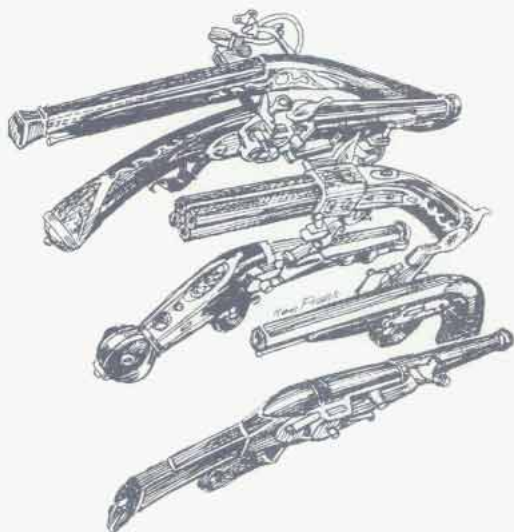

Weapons and Ability Bonuses

Generally, a character may apply his Strength bonuses to any weapon powered by his own muscle. Any hand-held weapon used to slash, bludgeon, or thrust at an enemy certainly counts, but weapons that don't inflict damage or don't have a type don't allow a character to use his attack bonuses. For example, a character's Strength has no effect on the use of a lasso or net.

Characters may use their reaction adjustment for high Dexterity when throwing or firing any kind of missile weapon. However, they do not use their Strength bonuses unless the weapon is thrown and complies with the conditions above. Firearms, bows, slings, and crossbows are not normally affected by a character's Strength.

Bows can be made to take advantage of a character's Strength bonuses, but must be custom-made. Refer to Chapter 6: Money and Equipment in the *Player's Handbook*.

The 16th-level Dart Specialist: It's ludicrous to allow a high-Strength character the full benefit of his muscular power if he insists on using tiny little weapons such as darts. A good way to address this kind of min-maxing is to limit the damage bonus granted by high Strength to the maximum roll of the weapon's base damage. A dart normally causes 1d3 points of damage against size M targets, so a character with exceptional Strength could gain a total of +3 to his dart's damage—but no more, even if he is normally entitled to a damage bonus of +4 or more.

Armor Descriptions

The armorer's craft evolved over the course of thousands of years, much as weapons evolved. The marvelous works of the German and Italian master armorers of the 15th century simply cannot be duplicated by craftsmen with more primitive technology. Therefore, armor is limited by time period just as weapons are.

The following descriptions note the adjusted base AC for a full suit of each armor type, and also a generic encumbrance value for typical humans in that armor. Player characters may accept these encumbrance values or use the more advanced encumbrance rules to total up their equipment weight.

The armor table also includes protective values for pieces of armor. In most cases, these are fractional—for

Weapons & Armor



example, a chain mail arm piece improves the wearer's AC by 0.5. For most PCs, this reduces the wearer from an AC of 10, so if a composite suit of armor improves the character's AC by 3.9 points, his actual Armor Class is a 6.1 (10–3.9), which rounds down to an AC of 6. Only round to the lower AC if the fraction is .3 or less; an AC of 6.1 is a 6, but a 6.4, 6.5, or 6.9 is considered to actually be AC 7.

Partial armor can always be bypassed by the use of the called shot rules in Chapter Two. The attacker suffers a –4 penalty for making a called shot, but of course he gets to make his attack against the defender's unprotected AC of 10. The best use for partial armor in the game is to simulate various forms of composite protection favored in different time periods; for example, medieval infantry often wore breastplates and helmets but did not wear armor on their legs or arms.

Last but not least, armors are loosely grouped into three basic types—plate armors, mail armors, and leather armors. Some weapons gain special attack bonuses against certain types of armor. For example, the heavy blow of a mace is especially effective against mailed opponents, because the flexibility of the mail allows the blow to cause damage even through thick armor.

Back-and-breast. (AC 6; enc. none; type plate) This armor is simply a steel breastplate and back piece, worn like a shirt. It protects the wearer's vital organs but leaves the limbs uncovered. Historically it saw use throughout the Renaissance.

Banded mail. (AC 4; enc. light; type mail) There is some debate over the existence of this armor in the Middle Ages, but Roman legionaries wore banded breastplates as part of the *lorica segmenta*. Banded mail consists of parallel bands or strips of armor covering the torso, shoulders, arms, and legs, with mail guarding the joints.

Brigandine. (AC 6; enc. none; type leather) A very common armor of the later Middle Ages and the east, brigandine consisted of a coat of leather plates. Each leather plate was a sandwich with steel strips inside of it. The joints and limbs were constructed with fewer armor strips for flexibility. Splinted mail, described below, is nothing more than a heavier version of brigandine.

Bronze plate mail. (AC 4; enc. light; type plate) This armor never existed as a full suit historically. However, bronze breastplates, greaves, and arm guards were quite common, especially in Greek and early Roman settings. With a full suit of bronze plate mail, the under-

lying chain mail backing that is found in normal steel plate mail is replaced by backing made of studded leather.

Buckler. The smallest shield used is the buckler. It is usually not more than a foot in diameter. Its small size makes it easy to carry, but it is of limited usefulness against anything except fencing weapons. The buckler's AC bonus can only be counted against the attacks of a single opponent in any combat round.

Cap. Steel, bronze, or iron caps are among the most common helmets until the later days of the Crusades. A cap is often worn over a mail coif for additional protection; the two together provide an AC of 3 for the user's head and neck. Caps often include nasals, or projecting bars, that cover the user's nose.

Chain hauberk. (AC 6; enc. light; type mail) Chain mail was first constructed in Roman times as shirts or skirts. Throughout the Dark Ages mail was reserved only for the wealthiest warriors. By the end of the Dark Ages, the most common form of mail was the hauberk, a long-sleeved coat that hung to the wearer's knees. Because the lower legs are vulnerable, the hauberk doesn't offer the same protection that a full suit of chain mail does.

Chain mail. (AC 5; enc. light; type mail) The full suit of chain mail appeared early in the Crusades, when chain leggings were added to the traditional hauberk. For more than a century mail was the universally favored form of protection in Western Europe and the Holy Land; armor experts refer to the 11th and 12th centuries as the Age of Mail.

Chain-lamellar. (AC 4; enc. light; type mail) Chain mail was used widely in Byzantium and eastern lands, too. It was common for eastern peoples to augment their lighter mail with heavier armor. Chain mail with lamellar breastplates, greaves, and arm guards was widely used by Byzantine, Turkish, and Persian cavalry.

Close-faced helm. This category includes a number of variations, ranging from steel war masks, to the Crusaders' barrel helms, to samurai helmets. The helmet offers excellent protection, but is heavy and can limit vision and hearing. In situations where field of view or clarity of hearing may be important, the DM can impose a –1 penalty to surprise checks for characters wearing close-faced helms.

Cord armor. (AC 8; enc. none; type leather) Only found in savage or exotic settings, cord armor consists of rope-like fibers woven and knotted into a thick, tough fabric. It may be found in places where leather is scarce.

Chapter Seven



Field plate. (AC 2; enc. moderate; type plate) The armorer's craft reached its peak during the Renaissance, when full suits of articulated plate armor were common. Field plate armor dispenses with the chain backing of plate mail or full plate armor to save weight. Instead, a light suit of padding, or *aketon*, would be worn beneath field plate. The considerable weight of this armor was distributed over the wearer's body, and a trained knight could lie down, stand up, or vault into the saddle while wearing heavy armor.

Full plate. (AC 1; enc. moderate; type plate) The final development of armor was full plate armor, which protected the wearer with padding, chain, and a suit of beautifully crafted interlocking plates carefully angled to deflect blows. Armor of this type could even withstand long-range gunfire, as long as the bullet didn't strike square on target. A well-made suit of full plate armor was the sign of high nobility; many lesser knights had to make do with far less impressive suits due to the great expense of this marvelous armor.

Gallic armor. (AC 8; enc. none; type leather) Reserved for the gladiatorial arena, Gallic armor consisted of leather leggings and a leather sleeve, with a wide metal belt. No free soldier would normally wear such light armor if better could be found.

Great helm. The great helm actually sits on a metal gorget, or throat-guard, instead of resting its weight on the wearer's head. The face is completely covered. The protection offered by the great helm is unmatched, but the wearer's visibility and hearing are seriously impaired; he suffers a -2 penalty to any surprise checks that might be affected by his ability to spot his enemy or hear someone sneaking up on him.

Half-plate. (AC 4; enc. light; type plate) As firearms became more prevalent, the usefulness of heavy plate armor rapidly declined. The trend towards more complete coverage reversed, and soldiers and knights began to discard all but the most critical pieces of armor. Half-plate consists of a breastplate and tassets, or hip armor, but the lower legs are left unarmored, as are the insides of the arms. Half-plate lingered on into the 17th century before disappearing altogether.

Hide. (AC 6; enc. light; type leather) Hide armors were rare in Western Europe, but saw some limited use in eastern settings. At the DM's option, hide armor can be used to simulate the buff coat—a Renaissance armor made of several layers of stiffened leather.

Hoplite armor. (AC 5; enc. light; type plate) The armor of the classic Greek warrior consisted of a bronze breastplate and greaves with a studded leather skirt. It

offered a good compromise of protection for vital areas without too much weight. Alexander's soldiers conquered half the world in armor like this.

Improved mail. (AC 4; enc. light; type mail) Several varieties of improved chain mail appeared during the Crusades. Bar mail consisted of small metal strips threaded through the links; double mail used heavier links double-joined; augmented mail used a thick leather backing to reinforce the coat. All types of improved mail offer better protection than normal chain mail, but at the price of increased weight.

Lamellar. (AC 5; enc. light; type mail) Lamellar armor consists of small, overlapping plates of metal sewn together or stitched to a backing of leather or cloth. It is similar to brigandine and splinted mail, but isn't sandwiched in leather like the other two armors. Lamellar is a very ancient armor that was used in Mesopotamia and ancient Egypt thousands of years before the rise of Rome. Byzantine and Persian cavalymen used breastplates of steel lamellar as part of their heavy armor.

Lamellar shirt. (AC 7; enc. none; type mail) Full suits of lamellar armor were very rare in the Bronze Age, but lamellar coats with cloth skirts were somewhat more common. This composite armor represents the best protection available to the common soldier in extremely ancient settings.

Leather. (AC 8; enc. none; type leather) Leather armor has been used by light troops since the Bronze Age. Leather can be toughened by treating it with oil in a process known as *cuir boilli*. This armor type uses *cuir boilli* pieces to reinforce vital areas and soft leather for the legs and arms.

Leather helm. The lightest helm available is made from *cuir boilli* leather reinforced by iron or bronze bands. The leather helm doesn't provide much protection compared to other types, but it's better than nothing.

Light scale. (AC 7; enc. none; type leather) Normal scale armor is made out of iron, bronze, or steel, but it's also possible to make scale armor out of *cuir boilli* leather scales, bone, or horn. Light scale is often the armor of nomadic or savage peoples who have difficulty finding metal to work with.

Lorica hamata. (AC 6; enc. none; type mail) This Roman armor consisted of a chain mail shirt and a skirt of leather reinforced with bronze or iron strips. It was an early armor used from the time of the Punic Wars into the 1st century A.D.

Lorica segmenta. (AC 5; enc. none; type mail) Lorica segmenta replaced lorica hamata and was used until about A.D. 350. It consists of a breastplate of banded mail

Weapons & Armor



and a reinforced skirt of studded leather armor.

Mail coif. The mail coif is a hood of chain mail that drapes over the neck and shoulders as well as the head. It is usually worn with a cap or beneath another helmet, since chain mail by itself doesn't offer much protection against impact weapons. If worn with a cap, the mail coif is AC 4; if worn under another helmet, it provides no additional protection but at least allows the user to remove his restrictive helmet and get a look around without baring his head completely.

Mail and plate. (AC 4; enc. light; type plate) Plate armor first appeared near the end of the Crusades as reinforcement for chain mail armor. Small breastplates were introduced first, but rapidly grew into full breastplates with complete leg and arm covering. The mail and plate armor describes an early form of plate mail in which a breastplate is worn over a full suit of chainmail.

Open-faced helm. Greek and Roman helmets normally fell under this category, as did many helmets of the later Middle Ages. The open-faced helm provides good protection and only moderately compromises vision and hearing. This category also includes the Renaissance morion, kettle helm, lobster-tail, and other such helmets.

Padded. (AC 8; enc. none; type leather) Padded or quilted armor is probably one of the oldest and most universal forms of personal defense. Even in the days of full plate armors, padded suits known as *aketons* were worn beneath the steel plate to cushion blows and help distribute the weight of the outer armor. Light troops of many time periods are often equipped with padded armor.

Plate mail. (AC 3; enc. mod; type plate) This is the cheapest and most common form of plate armor in the Middle Ages. Instead of attempting to articulate the joints and provide complete plate protection, portions of this armor are simply protected with chain mail. This form of armor was nothing more than an expanded suit of mail and plate, and the forerunner of true plate armor. Even in the age of full plate armor, simple plate mail was still common among poorer knights and professional mercenaries.

Ring mail. (AC 7; enc. none; type leather) Ring mail consists of a leather coat with rings sewn onto it. It slightly resembles chain mail, but the links do not interlock. In the Dark Ages, ring mail was a cheap substitute for true mail,

which was too expensive for many warriors. Some varieties of ring mail were used throughout the Middle Ages by light troops, artilleryists, and skirmishers.

Scale mail. (AC 6, enc. light, type mail) This ancient armor type consists of a leather coat or shirt with scales of metal riveted to it. (Some forms of scale mail were made with horn or leather—see Light Scale.) Scale mail was never widely used in the West, but saw extensive use in the Mideast and Orient.

Shield, small. The small shield, or *targe*, is usually a round shield about two feet in diameter. Some later medieval shields were triangular or square in shape. The small shield can be used against two enemies in a combat round, as long as they are in front of the character or on his shielded flank.

Shield, medium. This catch-all category includes anything from the Roman *scutum* to the Norman kite shield. It usually stands about three feet tall and is two to three

Armor Type	Common in...	Rare in...
Banded mail	HY	CR, RM
Brigandine	HY, RE, OR	ME, CR
Bronze plate	BR	RM
Chain mail	CR, HY	DA, RM, RE, OR
Cord armor	SA, SV	ME, OR, BR
Field plate armor	RE	HY
Full plate armor	RE	HY
Hide armor	SA, SV	BR, OR
Improved mail	ME, CR	HY
Leather armor	All	—
Light scale mail	SV, BR, RM, DA, OR	CR, HY, ME
Metal lamellar	DA, ME	BR, RM, OR, CR
Padded armor	All	—
Plate mail	HY	CR
Ring mail	DA, CR, HY	RE, ME, OR, BR, RM
Scale mail	BR, RM	DA, CR
Splint mail	ME, OR	CR, HY, RE
Studded leather armor	All except SA	—
Wood/bone armor	SA, SV	—
Back-and-breast	RE	HY
Chain hauberk	DA	CR
Chain-lamellar	ME	CR, DA
Gallic armor	RM	—
Half-plate armor	RE	HY
Hoplite armor	BR	RM
Lamellar shirt	BR	—
Lorica hamata	RM	—
Lorica segmenta	RM	—
Mail and plate armor	CR	HY
Three-quarter plate	RE	HY

SA=Stone Age; SV=Savage; BR=Bronze Age; RM=Roman; DA=Dark Ages; CR=Crusades; HY=Hundred Years' War; RE=Renaissance; ME=Middle Eastern; OR=Oriental.

Chapter Seven

feet wide. The medium shield can protect the wielder from up to three enemies per round, as long as they are in front of the character or on his shielded flank.

Shield, large. Also known as the body shield or tower shield, this mighty shield stands at least four feet tall and is two to three feet wide. It can protect the wielder against any attack from his front or shielded flank.

Splint mail. (AC 4; enc. light; type mail) Splinted armor resembles brigandine, but larger metal strips are used. The metal strips are riveted together in an overlapping pattern and then enclosed in two layers of leather. Splinted armor was not widely used in Western Europe, but was popular in India and the Far East. The *o-yoroi* of the samurai can be considered to be splint mail.

Studded leather. (AC 7; enc. none; type leather) Reinforcing leather with metal studs or small plates is an old idea; armor of this type has been used since the Bronze Age. It was still common among foot soldiers even as late as the Renaissance.

Three-quarter plate. (AC 3; enc. light; type plate) Like half-plate, three-quarter plate appeared when knights began to discard the less important pieces of their armor. There's little point in carrying around 70 pounds of armor when it won't stop a bullet or a heavy crossbow bolt. Three-quarter plate retains the breastplate, arm protection, hips, and thigh plates but dispenses with protection for the lower legs and inner part of the thighs, which would normally be protected by the horse.

Wood or bone armor. (AC 7; enc. none; type leather) In primitive or savage settings, metal may be unavailable for armor. Wood or bone lamellars and reinforced coats are not uncommon among people with little access to metal. Usually, armor of this type concentrates on protecting the torso while leaving the arms and legs free for mobility.

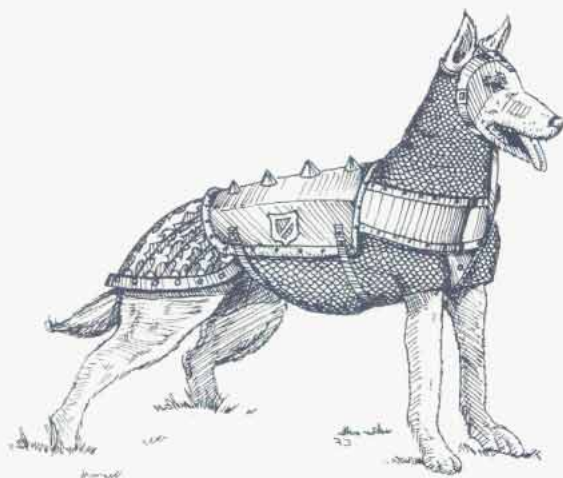

Barding

Warriors have been looking for ways to armor their mounts almost as long as they've been armoring themselves. It doesn't take a genius to figure out that an unarmored horse might be an easier target than the heavily plated knight who's riding it. Therefore, characters who plan on riding their horses into battle should try to acquire barding.

Armor Type	Cost	Armor Class	Weight
Leather scale	75 gp	7 (-1)	50 lbs
Scale	350 gp	6 (-2)	80 lbs
Padded	35 gp	8 (-1)	30 lbs
Chain	500 gp	5 (-2)	100 lbs
Plate and chain	750 gp	4 (-3)	130 lbs

The AC *replaces* the mount's natural Armor Class, if the barding AC is better than the animal's normal AC. If the animal's AC is better than the barding, then the barding simply improves the animal's AC by the number in parentheses.

For example, horses have a natural AC of 7. Scale, chain, and plate barding replace their natural AC. Since leather and padded armors don't provide an AC better than 7, they simply lower the horse's AC to 6 or 5, respectively.

Leather scale barding. This barding dates back to the Bronze Age, but also saw use in Roman times and the Dark Ages. It consists of a leather blanket with *cuir boilli* scales sewn onto it.

Padded barding. Often used by Crusaders, this light armor also allows a knight to display his colors on his mount.

Scale barding. The best barding available until the Hundred Years' War is scale barding. It consists of a coat sewn with metal scales. Scale barding was used by the princes and kings of the Bronze Age.

Chain barding. Only the strongest horses can carry an armored knight and a heavy coat of mail, too. Chain barding was not very common because of its expense and weight.

Plate and chain barding. The best armor available for horses came into use towards the end of the Hundred Years' War. The horse's forequarters, flanks, head, and neck are protected by steel plates, and loose chain skirts cover the rest. Like chain barding, plate barding is very heavy and very expensive. It would normally only be found on the mount of a great knight or prince.

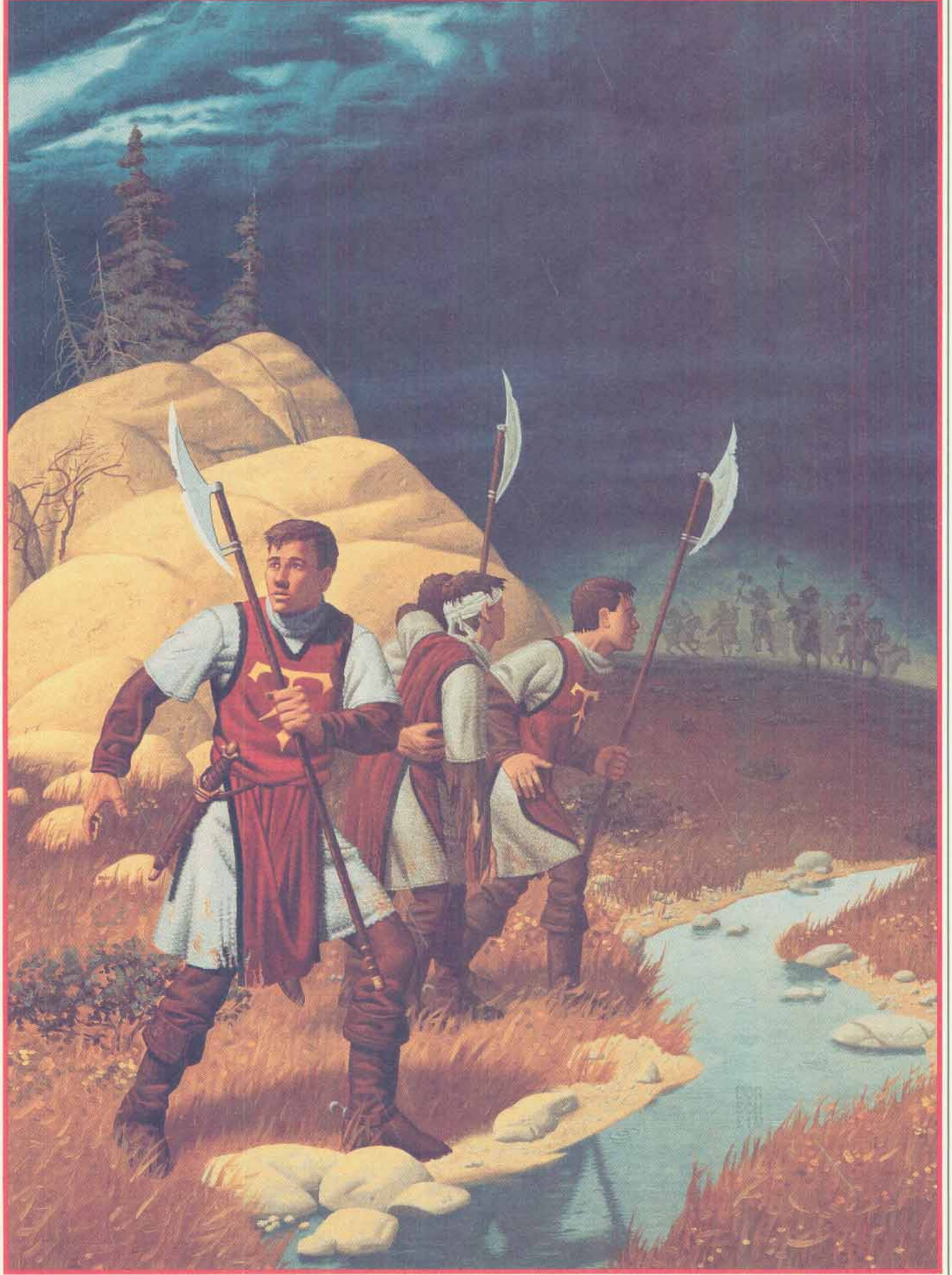

Chapter Eight: Siege Warfare



Small frays between bands of adventurers and their foes are not the only battles fought in a fantasy world. Companies of brigands roam the countryside, and there might be scores of troops in a town guard or castle garrison. In times of war, armies numbering in the thousands might take to the field.

Nor are hand-held weapons such as swords and spears the only deadly implements a hero is likely to face. Well-prepared opponents often employ war machines of ingenious design and fearsome potential. Likewise, defenders need not depend solely on the local terrain for protection; instead they might employ all manner of constructions and fortifications.

This chapter's first section, *War Machines*, discusses fighting equipment that generally is larger than typical hand-held weapons. Bombardment engines, vehicles, and miscellaneous devices are included. *Escalades* covers a wide variety of actions, including battering down common portals and scaling walls. *Sieges and Fortifications* discusses the lengthy processes of smashing through fortifications through brute strength. *Mass Combat* provides a way to quickly determine the outcome of a battle too large to play out using the PLAYER'S OPTION combat system. Finally, *Proficiencies* gives details on two new warrior proficiencies introduced in the previous sections.

Does This Belong in My Campaign?

Few campaigns will use the material presented here all of the time (castles, artillery, and massed troops are hardly commonplace), but most campaigns will find it useful occasionally.

The majority of the material in this chapter is intended for use with the combat system from Chapter One and the Battlefield rules from Chapter Three. It is not necessary to use the combat system with any of the material in this chapter, but your games will be greatly enhanced if you do. The rules on fortifications presented here use many terms and concepts from the material on battlefields, and it is necessary to be familiar with Chapter Three before using them. The material on sieges and on mass combat is intended to stand alone.

Siege Warfare



War Machines

Any piece of potentially useful battlefield equipment, offensive or defensive, can be considered a war machine if it is too large for a single character to use. A tree trunk used as a battering ram, a catapult loaded with greek fire, and a howdah strapped to an elephant's back all can be considered war machines.

Bombardment Engines

Any large device intended to hurl missiles qualifies as a bombardment engine. The most common types and their basic statistics are listed on the table below.

Bombardment engines are difficult to aim at individuals. Generally, a bombardment engine can target only units of creatures, buildings, other war machines, vehicles, ships, and single creatures of Gargantuan size; see the individual bombardment engine descriptions for exceptions.

It takes time and effort to set up a bombardment engine and prepare it to fire for the first time. The minimum preparation time is 10 minutes or the time required to change facing, whichever is greater. The number increases by 50% if a trained artilleryist is not on hand to direct the operation.

When used with the **PLAYER'S OPTION** combat system, a bombardment engine has a field of fire of 45 degrees left or right of its current facing. This is generous for most weapons included here, but it is assumed that a bombardment engine's slow rate of fire accounts for a considerable amount of manhandling between shots.

Range: Ranges are divided into minimum, short,

medium, and long categories. A weapon cannot be aimed at targets closer than its minimum range.

THACO: The chance to hit a target with a bombardment engine is a function of the engine, not the crew.

Damage: The number before the slash is the amount of damage inflicted on Man-sized or smaller creatures; the number after the slash is the damage inflicted on larger creatures. If there is only one value given, the damage is the same for all sizes of creatures. Some creatures are entitled to a saving throw to reduce or avoid damage. Damage to structures is covered in the Escalades and Siege and Fortifications sections.

Note that creatures immune to normal missiles are not immune to missiles from bombardment engines. Creatures immune to blunt weapons are immune to catapult and trebuchet missiles and to round shot fired from ballistae. Creatures immune to piercing weapons are immune to bolts from ballistae. Creatures immune to nonmagical weapons are immune to attacks from ballistae, catapults, and trebuchets (unless the missiles employed are enchanted). Cannon and bombard projectiles are blunt weapons, but they are propelled with enough force to harm creatures that are otherwise immune to blunt weapons. Cannons and bombards also can harm creatures that are immune to nonmagical weapons. Light cannons are treated as +1 weapons for determining which creatures they can harm. Medium cannons and great bombards are treated as +2 weapons, and heavy cannons are treated as +3 weapons.

Knockdown: The size of the die the weapon rolls for knockdowns.

Bombardment Engines

Weapon	Range M/S/M/L	THACO	Damage	Knock- Down	ROF	Change Facing	Crew	Cost	Target Size	Wt.	Spaces
Ballista, Light	-/11/22/33	12	2d6/3d6	d8	1/8	0	1	200	Any	100	1
Ballista, Medium	1/11/22/36	14	3d6/3d8	d10	1/12	0	2	300	H	200	2
Ballista, Heavy	2/12/24/39	17	3d10/3d12	d12	1/16	0	4	400	H	400	2
Bombard	18/-/-/40*	17	2d10/2d12	d12	1/15	30	3	10,000	G	600	1
Bombard, Great	36/-/-/80*	19	3d10/3d12	d20	1/18	30	5	30,000	G	1,200	2
Cannon, Light	-/15/45/90	12	1d12x5	d10	1/15	0	3	10,000	H	400	1
Cannon, Medium	-/20/60/120	14	1d12x5	d12	1/18	0	4	15,000	H	1,000	1
Cannon, Heavy	-/30/90/180	17	1d12x5	d20	1/30	15	6	30,000	H	2,000	2
Catapult, Light	15/-/-/30*	14	2d10	d8	1/8	0	1	250	H	200	1
Catapult, Medium	15/-/-/33*	15	3d10	d10	1/12	0	3	350	G	300	2
Catapult, Heavy	18/-/-/36*	16	3d10	d12	1/16	20	5	500	G	500	2
Trebuchet	24/-/-/48*	17	4d10	d12	1/16	30	8	750	G	1,000	4

Chapter Eight



ROF: (Rate Of Fire) This is how often the weapon can be fired if fully crewed; 1/8 means the weapon can fire once every eight rounds.

Change Facing: This is the number of rounds required to change the weapon's facing 45 degrees. Any weapon listed as "0" can change facing during the End-of-Round step of a round in which the weapon was fired.

Crew: The number of Man-sized creatures required to operate the weapon. If fewer crew are available, the weapon's rate of fire decreases by one for every missing crew member, and the weapon cannot be operated at all if the available crew is less than half the required number. Extra crew can be allocated to the weapon to maintain its rate of fire in the face of casualties among the crew. At the DM's option, two Small or four Tiny creatures can replace one Man-sized creature; one Large creature can replace two Man-sized creatures, one Huge creature can replace three Man-sized creatures, and so on. If at least one trained artilleryist is not on hand to supervise the crew, the rate of fire decreases by one. Creatures must have manipulative appendages and a racial intelligence of at least low to serve on a crew.

Target Size: The smallest creature the engine can target individually; see the engine's description for details.

Weight: The engine's approximate weight in pounds.

Spaces: The number of map spaces the engine occupies on the map.

*Indicates that the usual -5 modifier for long range shots does not apply.

Ballista

This engine looks something like a giant crossbow mounted on a swivel. It usually fires spear-like bolts, but some versions fire round shot of stone or metal; both types use the same basic statistics. Ballista projectiles have a relatively flat trajectory, and they are fairly accurate.

A light ballista can be aimed at any target in sight, provided the weapon is fully crewed. A light ballista with a partial crew can fire at single creatures of Large or greater size. A medium or heavy ballista can fire at a single Huge creature, or at a Gargantuan creature if partially crewed. Any ballista's field of fire is limited to 45 degrees left or right of the weapon's facing at the beginning of the round. A ballista's facing can be changed up to 45 degrees during the last phase of any round when it fires.

Bombard

The term "bombard" encompasses a broad category of nonstandardized, primitive gunpowder weapons that fire large stone or iron balls in a high arch. A typical bombard has a short, thick barrel cast from bronze and set in a rigid wooden base. More advanced siege mortars from the cannon era also use the bombard statistics.

A single shot from a normal bombard requires 10 charges of *smoke powder* or gunpowder; a great bombard requires 20 charges, and both types of bombards are subject to misfiring (see Chapter Seven for details). The heat and debris left in the barrel after firing accounts for the weapon's relatively slow rate of fire, as the weapon must be cooled and cleaned before it can fire again.

A bombard's facing is fixed at the beginning of a battle; a full crew working nonstop for 30 minutes can change a bombard's facing 45 degrees. For a partial crew, add 10 minutes to the time requirement for each missing crew member; a crew at half strength cannot move a bombard.

The bombard's thunderous roar can confuse or panic creatures unaccustomed to loud noises or normally fearful of thunder. This includes most creatures with a basic morale score of 10 or less and any creature generally unfamiliar with explosives or magic. Such creatures must check morale if they are within 40 yards of a bombard when it fires. Creatures usually lose their fear of a bombard's noise if they win an encounter against an enemy armed with one or if they spend a month or so getting accustomed to the sound.

Cannon

These weapons are more refined versions of bombards. They have long, slim barrels made from high-quality bronze and they fire wrought-iron shot in a low, flat trajectory. They are fairly accurate.

Cannons are subject to misfires just as bombards are. A shot from a light cannon requires 10 charges of *smoke powder* or gunpowder. A medium cannon requires 15 charges, and a heavy cannon requires 20 charges.

A light or medium cannon can change facing 45 degrees during the End-of-Round step of any round when it fires. A full crew working nonstop can change a heavy cannon's facing in 15 minutes.

The sound of cannon fire can panic some creatures just as a bombard's can.

Siege Warfare



Catapult

This engine usually consists of some sort of lever mounted on a sturdy frame. The lever acts as a throwing arm and is fitted with a cup or sling to hold the projectile. When fired, a catapult lobs the projectile high into the air. Tension provides the catapult's power. In primitive catapults, the lever was made from some flexible material (usually green wood) and provided its own power when it was bent back and released. More sophisticated catapults were equipped with a rigid arm powered by a mass of twisted skeins (usually horse-hair). Ancient catapults often resembled ballistae aimed upward to fire indirectly; all types of catapults use the same basic statistics.

Catapults usually fire large stones, but they can be loaded with almost anything: small stones, chains, dead animals, or anything else small enough to fit in the sling or cup and not so heavy that it overloads the lever. Large objects inflict the damage listed on the table. Masses of small objects can inflict an extra die of damage against most creatures but are useless against structures and any creature with a natural Armor Class of 0 or better (including characters with an Armor Class of 0 before shield or Dexterity modifiers).

A light catapult with a full crew can target Huge creatures.

A light or medium catapult can change facing 45 degrees during the End-of-Round step of any round when it fires. Heavy catapults generally are left in place once they are sited for a battle. A full crew can change a heavy catapult's facing after 20 minutes of work.

Trebuchet

These massive engines are similar to catapults, but they derive their power from gravity. A trebuchet's throwing arm is a rigid beam with a heavy weight at one end and a sling or cup for projectiles at the other. When the beam is released, the force of the falling weight hurls the projectile in a high arch. Like catapults, trebuchets fire large stones or masses of smaller objects.

Trebuchets generally are left in place once they are sited for a battle. A full crew can change a trebuchet's facing after 30 minutes of work.

Bombardment Engine Procedures

A bombardment engine fires in the very slow phase of the round when its loading is completed. If loaded and aimed during a previous round, a bombardment engine can fire in the very fast phase.

Indirect Fire Engines

Bombards, catapults, and trebuchets fire their projectiles in a high arch; they are inaccurate and cannot really be aimed at anything; the crew simply points the engine in the target's general direction and hopes the missile will land somewhere nearby.

All targets are considered Armor Class 0, but there is no range modifier. The attack roll is modified as follows:

- +3 for stationary targets;
- -3 for targets moving at a rate greater than 3 but less than 12;
- -6 for targets moving at a rate of 12 or greater;
- +4 for the second and subsequent shots at a stationary target;
- +2 for targets whose largest dimension is greater than 30';
- +4 for targets whose largest dimension is greater than 90';
- +6 for targets whose largest dimension is greater than 270'.

Cover generally is not a factor when resolving indirect fire, but concealment can be. Indirect fire generally can arch over obstacles between it and the target, provided that the obstacle is no higher than 150% of the distance between the obstacle and the engine, or the obstacle and the target, whichever is less. For example, a wall 90' feet high would not block indirect fire unless it was within 60' of either the engine or the target. Note that in many cases it is easier for an engine to fire at a feature or structure where opponents are hiding than it is to fire at the opponents themselves.

If a creature is too small to be targeted individually, an indirect fire engine still can fire at the 15' square area containing the creature. The base modifier is 0 (because the target is not *larger* than 30' long). Modifiers for the small target's movement apply (it's hard to hit the right area when the creatures within it are moving). The attacker must select an intended impact square for the missile; any of the nine squares in the area can be selected.

Hits: An engine's missile tends to bounce or shatter on impact and affects an area, as shown on the accompanying diagrams. Creatures within the area of effect suffer damage listed for the weapon. Creatures with 5+1 or more Hit Dice can roll a successful saving throw vs. petrification to avoid the damage; modifiers for Dexterity and magical protections apply. A creature that has suffered a direct hit (by being in the impact square or

Chapter Eight

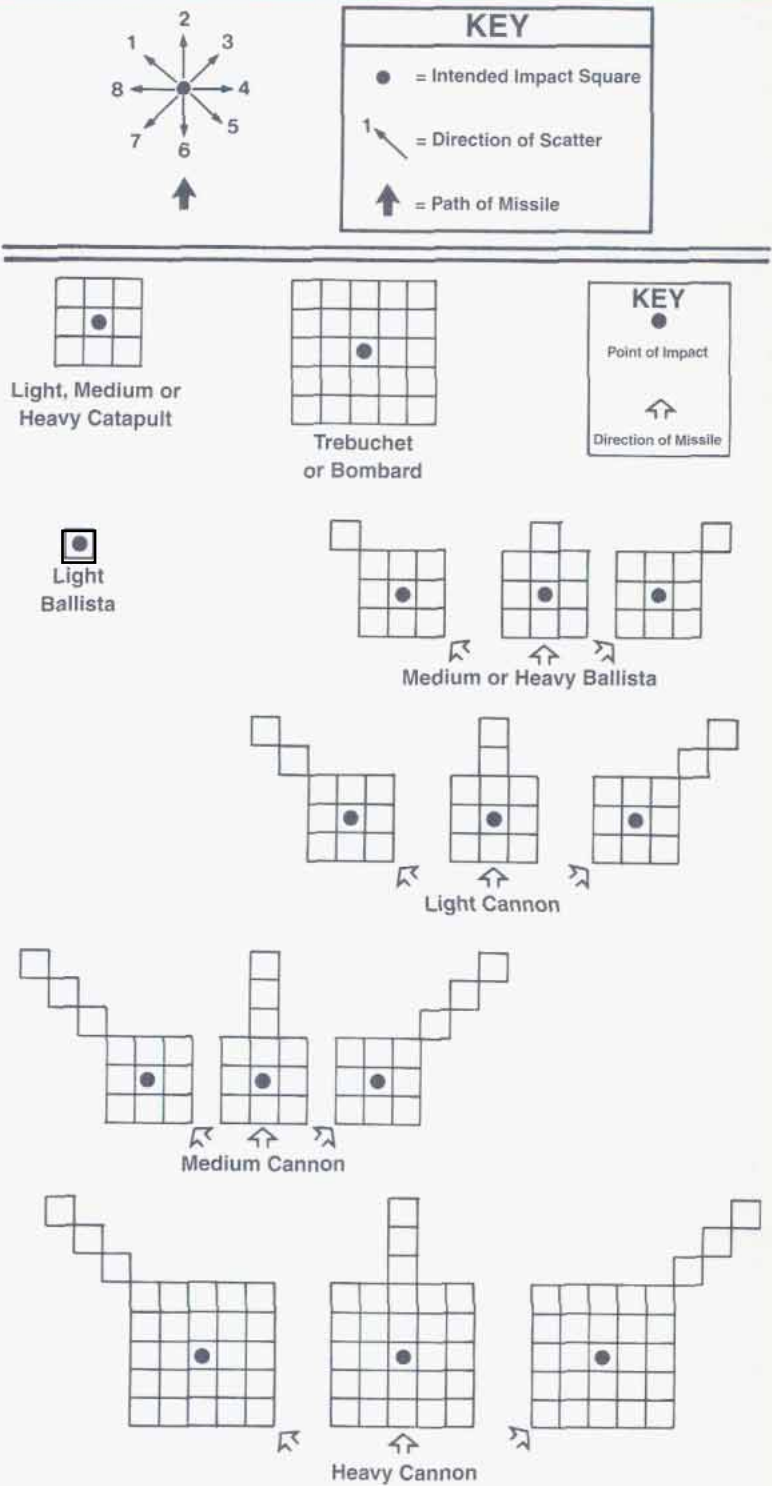

Diagram 13:
Bombardment Areas of Effect

by being large enough to qualify as a target and getting hit) is allowed no saving throw even if normally eligible for one. Creatures with hard cover between them and the impact square get a saving throw even if not normally entitled to one. Creatures under cover get bonuses to their saving throws; see Chapter One.

If the engine is firing at an area containing creatures too small to target individually, the shot never lands exactly where intended. Follow the procedure outlined below for misses, but roll 1d4 for distance.

Misses: To determine where the shot actually falls, roll 1d8 on the indirect fire scatter diagram to determine the direction of the miss; then roll 2d6 to determine the distance in squares from the intended impact square and the actual impact square. It is possible for the shot to fall inside the engine's minimum range or outside its maximum range. Creatures in the area where the shot falls suffer the effects of a hit.

Hits and Misses Against Large Creatures: If the missile scores a direct hit on a creature large enough to qualify as a target, there is no effect on creatures in the adjacent squares. The creature's body prevents the missile from bouncing or shattering. If a direct attack on a large creature misses, the attacker rolls for scatter. The intended impact square is always the square the creature occupies. If the creature occupies more than one square, the intended impact square is always the square closest to the engine.

Critical Hits and Knockdowns: Only direct hits can be critical hits or cause knockdowns. If the rules from Chapter Six are in play, indirect fire engines inflict Large bludgeoning criticals.

Flaming Projectiles: Catapults and trebuchets can be loaded with

Siege Warfare



missiles soaked in pitch or a similar flammable substance. The missile's range is reduced by $\frac{1}{2}$. When it strikes, the missile scatters flaming debris over its normal area of effect. The debris burns for two rounds, inflicting 2d6 points of damage the first round and 1d6 points of damage the second round. The effect on wooden structures is the same as flaming oil. A catapult also can hurl canisters of Greek fire. A Greek fire cannister also reduces the catapult's range by $\frac{1}{2}$. The cannister breaks on impact and scatters Greek fire over the catapult's normal area of effect.

An Example of Indirect Bombardment

A group of five dwarves led by a 6th/6th-level fighter/cleric has located a fortified goblin village. They hunker down in an ancient ruin about 300 yards from the village walls to discuss plans. Unfortunately for the dwarves, an alert sentry has spotted them and the goblins ready their medium catapult for a shot at the intruders. The dwarves have taken cover behind an old stone wall 12 feet high; they sit with their backs to the wall while they talk. Because the dwarves are within 8 feet of the wall, the catapult cannot target them. Even if the dwarves were in the open, the catapult could only target their area because they are Man-sized creatures.

The goblins decide to fire at the top of the wall and hope for the best. The wall is stationary and several hundred feet long. However, the goblins are aiming at one specific section, so the DM decides there is no attack bonus. Because the dwarves are the true target of the attack, the DM decides to impose the standard -4 penalty for 90% concealment (it might be a fairly easy task to hit the wall, but it's a bit more difficult to strike the section of wall directly above the dwarves' heads). The goblins have the catapult loaded with a mass of small stones, which gives them an extra die of damage against creatures

(4d10 points of damage in this case). The attack roll is a 12, a miss. (A medium catapult's THACO is 15, so the goblins needed to roll a 19 or better to hit.) The goblins roll 1d8 for scatter and get a 3, indicating an overshoot to the right. The goblins now roll 2d6 for distance and the result is a 7, so stone shot impacts 7 squares away from the aiming point, too far away to score any incidental hits on the dwarves (see diagram 14).

When they see the catapult stones dropping beyond them, the dwarves decide to leave, intending to exit through the far side of the ruins and return home. The medium catapult is reloading and cannot fire again before the dwarves get away. Unfortunately, the goblins also have two light catapults, and the sentry alerts their crews to the dwarves' flight.

Because the dwarves' movement takes them more

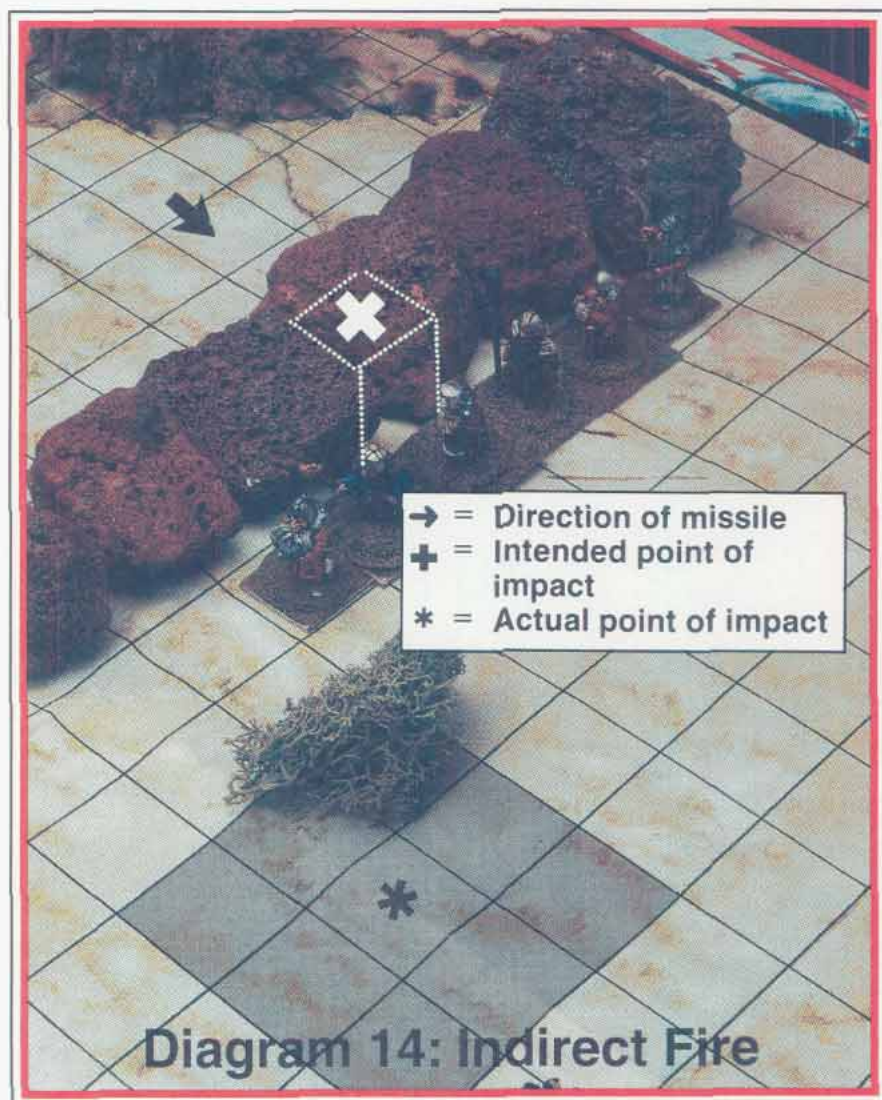

Chapter Eight

than 8 feet away from the wall, the light catapults can hit them. The goblins must fire at the area where the dwarves are. Their attacks receive a -3 penalty for targets moving faster than 3 but slower than 12. The crews have an adjusted THACO of 17 for these shots. The first crew rolls a 6, a miss, but the second crew gets a 20, a hit. The scatter and direction dice place the miss too far away to hurt the dwarves. Because the catapult that hit was firing at an area containing small targets, the hit also scatters. The goblins roll a 2, indicating a straight overshoot. Because the shot was a hit, the goblins roll 1d4 for distance and get a 1, so the shot lands right in front of the dwarves. The leader and two dwarves are within the area of effect. The two dwarves are one-Hit-Die creatures and they have no cover, so they are not allowed a saving throw. The damage roll is

a 16, which kills both dwarves. The leader is allowed a saving throw vs. petrification to avoid the damage and the roll is successful. The leader takes no damage and beats a hasty retreat with his three surviving followers.

Later that day, a monstrous 20' umber hulk (a true mutant — it is considered size Huge for the purposes of this example) bursts from the ground and attacks a goblin patrol about 200 yards from the village. If the umber hulk were much closer, it would be within the minimum range for the catapults (150 yards). Most of the patrol flees, leaving one unfortunate comrade trapped in the umber hulk's mandibles. The medium catapult cannot target on Huge creatures, so it must fire at the area containing the umber hulk. The crew selects a square next to the umber hulk as the intended impact square (they hope to score a lucky direct hit by rolling the right combination of scatter and distance dice).

The umber hulk remains in place while crushing its goblin meal, but part of its body remains hidden below ground, so the DM applies a -1 penalty to the shot for 25% concealment, giving the medium catapult an adjusted THACO of 16. The goblins roll an 11, a miss. The scatter die is a 7, short and to the left; the roll for distance is a 6, and the shot lands too far away from the umber hulk to do any damage. Unfortunately, two of the fleeing goblins are in the shot's area of effect and are killed (see diagram 16).

The two light catapults can fire at Huge creatures. With the -1 modifier for concealment, the light catapults have adjusted THACOs of 15. The attack rolls are 15 and 6. The first shot hits the umber hulk, and because of the direct hit, the umber hulk gets no saving throw and suffers $3d10$ points of damage from it (the goblins are still using masses of small stones). The miss scatters, using the square containing the umber hulk's head as the intended impact square. The roll is a 2, a straight overshoot. The distance roll also is a 2, which places the umber hulk within the shot's area of effect in spite of the miss. The umber hulk

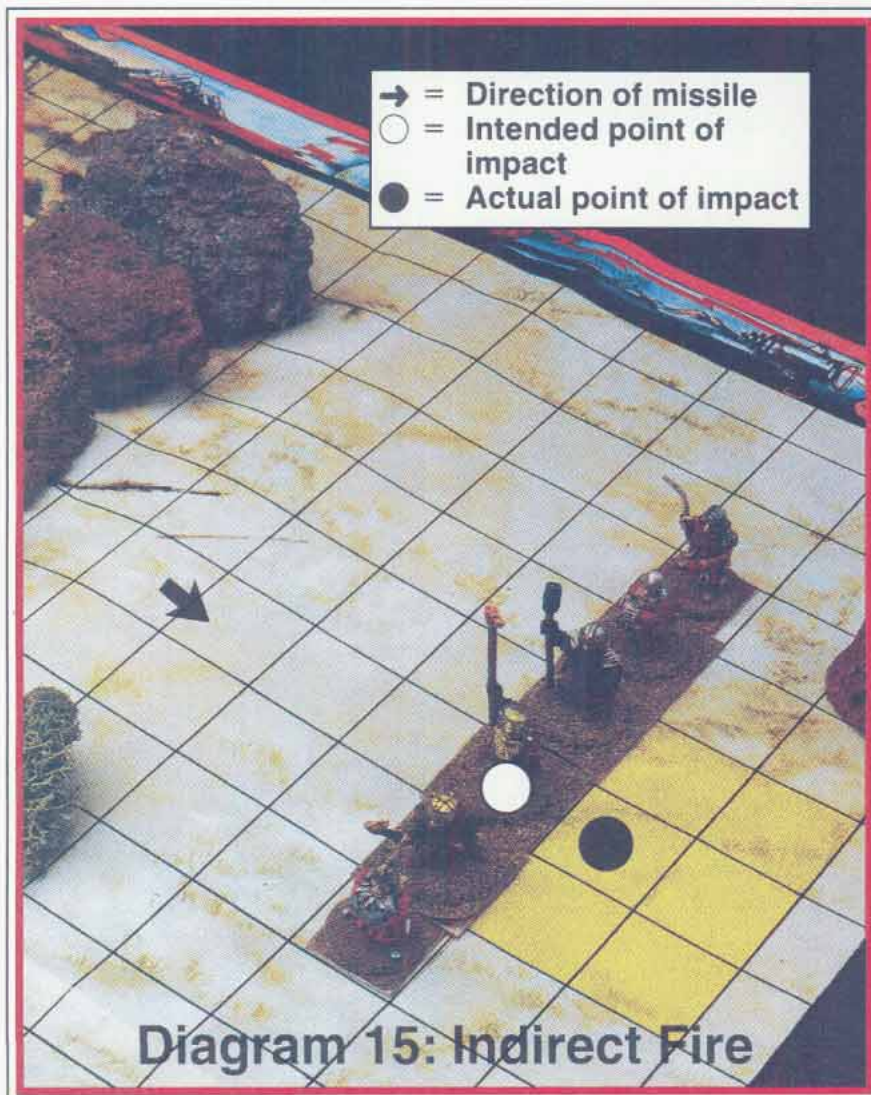

Siege Warfare



has 8+8 Hit Dice and gets a saving throw vs. petrification to avoid damage; it rolls a 19, easily succeeding. Nevertheless, the direct hit convinces it to retreat below ground with its prize.

Direct Fire Engines

Ballistae and cannons fire their projectiles in a low, flat curve. They are fairly accurate, though somewhat difficult to aim at small targets. Only light ballistae can be aimed as freely as a hand-held weapon can; larger engines can hit small targets only by aiming at the area containing the target.

All targets are considered Armor Class 10. If the target is a creature (not an area containing a creature) bonuses from Dexterity and magical protections apply. The attack roll is modified as follows:

- +3 for stationary targets;
- -3 for targets moving at a rate greater than 3 but less than 12;
- -6 for targets moving at a rate of 12 or greater;
- +4 for the second and subsequent shots at a stationary target;
- +2 for targets whose largest dimension is greater than 30';
- +4 for targets whose largest dimension is greater than 90';
- +6 for targets whose largest dimension is greater than 270';
- -2 for targets at medium range;
- -5 for targets at long range.

Diagram 16: Indirect Fire



Chapter Eight



Modifiers for cover and concealment also apply. Concealment versus direct fire bombardment engines is easier to find than true cover, as few barriers are substantial enough to resist hits. For example, a thick hedgerow might provide cover from arrows and sling stones, but it can provide only concealment against cannon fire.

The procedures for determining the effects of hits and for determining exactly where a direct fire missile lands are generally the same as for indirect fire engines, except that hits in a 15' area containing creatures too small to target individually roll 1d3 for scatter distance. Direct fire engines roll 2d4 for scatter distance when they miss.

Cannons: Creatures within a cannon shot's area of effect suffer 1d4 points of damage even if they make their saving throws. All cannons have the same basic damage listing against creatures—1d12x5. Roll 1d12 and multiply the result by five. This represents the possibly catastrophic effects of coming into contact with the cannon ball or the shrapnel a cannon ball impact produces. If the 1d12 roll is 10 or higher the affected creature also must save vs. death or be killed outright (see the Death from Massive Damage rule in Chapter 9 of the *PHB*).

Critical Hits and Knockdowns: Only direct hits can be critical hits or cause knockdowns. If the rules from Chapter Six are in play, cannons inflict Large bludgeoning criticals, and most ballistae inflict Large piercing criticals. Some ballistae fire shot instead of bolts and inflict Large bludgeoning criticals.

Flaming Projectiles: Ballistae can be loaded with bolts tipped with wads soaked in pitch and wrapped in cloth. The flaming bolt's range is reduced by $\frac{1}{2}$ and it inflicts normal damage and 1 point of additional fire damage if it scores a direct hit. The flame can set fire to wooden structures.

An Example of Direct Bombardment

The Huge umber hulk from the earlier example later discovers a community of gnomes and charges to the attack, sending the gnomes scurrying into their burrows. The gnomes have installed several light ballistae and a light cannon for defense. Two ballistae and the cannon take aim at the umber hulk while it dashes about trying to locate its vanished prey. The umber hulk is about 200 yards away from the bombardment engines.

Light ballistae can individually target creatures of any

size. The ballistae have medium-range shots. The range imposes a -2 penalty and the scorpion's movement of 6 imposes an additional -3. The ballistae have adjusted THACOs of 17. The attack rolls are 5 and 20. The 5 is a miss; because the missile was targeted directly at the umber hulk, the intended point of impact is the umber hulk's square closest to the ballista. The gnomes roll a scatter die and get an 8, indicating a miss to the left. Now they roll 2d4 for distance and get a 2, so the missile lands two squares away and has no effect on the umber hulk. Fortunately, there were no gnomes in the area to be hit by stray missiles.

The 20 is good enough to score a critical hit against the umber hulk's effective Armor Class of 10, even with a -5 attack penalty. The umber hulk is a Huge creature, and it suffers 3d6 points of damage (and possibly a severe piercing critical). The damage dice total 11 points of damage.

The light cannon can also target a Huge creature, so the crew aims it at the umber hulk. Its adjusted THACO is a 19. The attack roll is an 8, a miss. The scatter roll is a 6, short and dead ahead. The distance roll is only a 2, which just barely places the umber hulk within the shot's area of effect. The umber hulk has 8+8 Hit Dice, and is allowed a saving throw vs. petrification. It rolls a 4, a failure. The umber hulk suffers 1d12x5 points of damage (it would have suffered 1d4 points of damage even if it had been successful). The damage roll is an 8, inflicting 40 points of damage, enough to kill it after the 11 points of damage the umber hulk suffered from the ballista bolt.

Vehicles Most vehicles are simply used to get people or materials from place to place and have no function on the battlefield, except as objects of contention (wagonloads of rare merchandise or tax money often attract considerable attention). Some vehicles are designed to function as weapons, however, and most offer their passengers some concealment or cover. The most common types are listed below.

Chariot

These lightweight, two-wheeled vehicles are usually open topped. They are fairly quick and maneuverable. One to four large creatures can be hitched to a single chariot. An animal drawing a chariot can pull twice its normal (unencumbered) load at $\frac{2}{3}$ of its normal movement rate. Each additional animal added to the

Siege Warfare



team either increases the movement rate by one point or adds its maximum load to the chariot's useable load.

For example, two light horses could pull a 340-pound chariot load at a movement rate of 17 or a 680-pound chariot load at a rate of 16. Standard movement rates for fully loaded chariots are given in the individual descriptions below.

A chariot must stop immediately if an animal drawing it is killed. The driver or a passenger must spend a half-move action getting out and disentangling the animal and an additional half-move action or an attack cutting it loose. Cutting an animal loose requires a knife or slashing weapon.

Although chariots are highly maneuverable vehicles, they are not as agile as characters. A chariot must spend one point of movement to change facing. A chariot cannot change facing in response to attacks. If a chariot changes facing more than four times during a round, the driver must make a driving check for each additional change or the chariot flips over.

Chariots function best on smooth, fairly level ground. Chariots must avoid most obstacles; at the DM's option, chariots can attempt to cross obstacles less than 2' high (or deep) at a cost of two movement points per square, but a driving check is required to avoid flipping over. If a chariot crosses any terrain where the footing reduces movement, the chariot must pay the movement penalty and must pass a driving check at the end of any phase when it attempts to move or change facing.

A chariot moves on its driver's base initiative phase.

A chariot has no cargo capacity beyond what its passengers can carry on their persons (though passengers can lay their packs at their feet while riding).

A chariot can perform overruns as though it were a Huge creature; use the driver's THACO to resolve the attack of opportunity when an opponent is knocked down (see Chapter

One). Chariots are treated as Huge creatures when resolving fire from bombardment engines. A chariot occupies as many squares on the map as required to accommodate the figure representing it, but never less than four squares in any case.

A chariot's passenger capacity, protective value, and other characteristics vary with the type of chariot:

- A light chariot's car can hold as many creatures as one map square (one Large creature, two Man-sized creatures, and so on; see Chapter One). If the passengers go into close order so they can fit into a car they need not all have the same facing, but the driver must face forward. Man-sized passengers in a light chariot can claim 50% concealment from frontal attacks.



Chapter Eight

An overrun attack vs. a Large or Man-sized creature with a light chariot requires a driving check if the opponent is knocked down. If the check fails, the chariot flips over.

A light chariot drawn by two light horses can carry two armored men at a speed of 18.

- A medium chariot's car can hold as many creatures as two map squares. Man-sized passengers in a medium chariot can claim 50% cover from frontal attacks and 50% concealment from flank attacks.

An overrun attack vs. a Large or Man-sized creature with a medium chariot requires a driving check at +1 if the opponent is knocked down. If the check fails, the chariot flips over.

A medium chariot drawn by three light horses can carry four armored men at a speed of 18.

- A heavy chariot's car can hold as many creatures as three map squares. Man-sized passengers in a heavy chariot can claim 50% cover from frontal and flank attacks.

Heavy chariots do not require driving checks when making overruns.

A heavy chariot drawn by four light horses can carry six armored men at a speed of 18.

A chariot driver cannot attack while the vehicle is moving, except for swerving attacks (see below).

Chariot passengers get their full allotment of melee or missile attacks regardless of the chariot's movement. Passengers cannot make melee attacks against opponents in front of the chariot unless they are armed with weapons long enough to reach those squares. Passengers make their melee attacks in the normal initiative order.

If the chariot is moving during an action phase when a passenger makes an attack, the passenger attacks at the end of the chariot's movement. If a chariot is moving at full speed, any missile or melee attacks the passengers make suffer a -2 attack penalty. If the chariot moves at half speed or less, the attack penalty is -1. There is no penalty for attacking from a motionless chariot.

It is not possible to cast a spell from a chariot moving at greater than half speed or from a chariot moving over rough ground at any speed. If the chariot is moving at half speed or less, a passenger can cast a spell only if another passenger helps steady him.

Any chariot can be equipped with scythe blades on its wheels and the front of the car. A scythe chariot inflicts an extra 2d6 points of damage when making

overruns. If the defender is not knocked down during an overrun attempt the attacker still can make an attack of opportunity that inflicts 1d6 points of damage.

A character driving a scythe chariot also can swerve, making his normal allotment of melee attacks against single creatures in the car's flank squares. The attacks are made during the chariot's movement phase and are resolved as normal melee attacks except that the defender receives no Armor Class bonuses for Dexterity or a shield and the attack receives no attack roll or damage bonuses from Strength. If the attack hits, treat it as a successful overrun; the minimum damage is 2d6. If a swerve attack inflicts a critical hit, treat the scythe as a large slashing weapon.

Howdah

A howdah is a fighting platform strapped to a beast's back. Howdahs usually are used on Huge or larger creatures, but they can be used on Large creatures as well.

Most howdahs are open topped and provide 50% cover to Man-sized creatures inside against attacks from the howdah's front, flank, or rear.

Like a chariot, a howdah's passenger capacity is measured in map squares. A howdah's weight and maximum capacity varies with the size of the creature that carries it, as follows:

Creature Size	Capacity*	Weight
Large	1	50 lbs.
Huge	2	100 lbs.
Gargantuan	3	150 lbs.

*Maximum capacity; Huge and Gargantuan creatures can carry smaller howdahs. Some common sense adjustments are necessary. For example, polar bears are Huge creatures, but their rounded bodies and rocking gait limits them to one-space howdahs at best.

Unless the beast carrying a howdah has at least low intelligence, one passenger must act as the driver or *mahout*. Usually, the mahout does not ride in the howdah, but in a saddle located near the creature's head where the mahout can issue commands more easily. A mahout mounted this way counts against the beast's total load, but not the howdah's capacity; thus a war elephant could carry four men in a howdah, plus a mahout in a saddle. A beast without a mahout acts as an NPC under the DM's control.

A mahout usually is completely occupied with con-

Siege Warfare



troling the beast. If the beast is intelligent or exceptionally well-trained, the mahout can function as a mounted character.

Passengers in a howdah can fire missiles, cast spells, or make melee attacks (but see the note on elevation, below) as though stationary as long as the beast carrying the howdah does not charge, sprint, engage in melee, or attempt an overrun. If the beast charges, engages in melee, or attempts an overrun, everyone in the howdah must declare a half-move action to stay inside and keep steady. If the beast sprints, everyone in the howdah must declare a full-move action to stay inside and can do nothing else. Passengers can try to jump out; a character who jumps out of a howdah is considered knocked down and suffers 1d6 points of damage unless he rolls a successful saving throw vs. breath weapon.

Characters riding a Huge beast are considered to be one square above the battlefield, while characters riding a Gargantuan beast are considered two squares above. Characters elevated above the battlefield cannot make melee attacks or be attacked in melee unless weapons with sufficient reach are employed or the opponent is the same size as the mount, larger than the mount, or no more than one size class smaller than the mount. For example, a man riding in a triceratops howdah and armed with an axe could not attack or be attacked by a footman armed with a club, but he could attack or be attacked by an ogre.

A creature carrying a howdah moves on its base initiative phase.

Carrying Capacities For Beasts

If a creature's carrying capacity is not listed in the *PHB*, assume that most creatures can carry five pounds per point of Strength (see the formula for computing this in Chapter Two); particularly large or sturdy quadrupeds can carry 10 pounds per point of effective Strength. To these numbers add 400 pounds if the creature is Huge and 600 pounds if the creature is Gargantuan.

The resulting number is the creature's normal load, which allows movement at the creature's base speed. The creature can carry 150% of its normal load and move at $\frac{3}{4}$ speed and it can carry twice its normal load and move at $\frac{1}{2}$ speed. A flying creature reduced to $\frac{3}{4}$ speed loses one maneuverability class; a flying creature reduced to $\frac{1}{2}$ speed cannot fly.

Note that this is intended as a quick method for determining carrying capacities. Where previously published information conflicts with the numbers pre-

sented here, choose the one that seems most appropriate. Some sample calculations are provided in the table on the next page.

Note that the size category of the African elephant has been altered from its listing in the *Monstrous Manual*. It seemed only reasonable that the elephant's carrying capacity should be equivalent to, if not greater than, the polar bear, a Huge creature as well.

Wagon

These cumbersome four-wheeled vehicles are useful for carrying passengers or cargo. One to 12 large creatures can be hitched to a wagon. An animal drawing a wagon can pull triple its normal (unencumbered) load at half its normal movement rate. Additional animals attached to a wagon either increase the wagon's movement rate by one or add their tripled load to the useful load. For example, two light horses could haul a 510-pound wagon load at a speed of 13 or a 1,020-pound wagon load at a speed of 12.

A wagon must spend a movement point to change facing, and each change of facing must be separated by at least one square of straight movement. A wagon cannot change facing in response to attacks. If a wagon changes facing more than twice in a round, the driver must make a driving check on each additional change or the wagon tips over.

Like chariots, wagons function best on smooth, level ground. Unlike chariots, wagons cannot attempt to cross obstacles. Unstable footing slows wagons and can cause them to flip over.

A wagon moves on its driver's base initiative phase.

A wagon can perform overruns as though it were a Huge creature. Wagons are not particularly difficult to avoid, and the target gets a +2 bonus to the knockdown saving throw. All other modifiers apply. For example, a human subjected to a wagon's overrun would normally have a -4 penalty to the knockdown saving throw for being two sizes smaller than the wagon, but the penalty is reduced to -2 because of the wagon's +2 modifier.

A wagon is treated as a Huge target when resolving fire from a bombardment engine. A wagon occupies as many squares on the map as required to accommodate the figure representing it, but never less than four squares in any case.

A wagon's cargo and passenger capacity is determined by the number of animals pulling it and by its

Chapter Eight

Carrying Capacities for Beasts

Creature	Size	Normal Load/ Speed**	Moderate Load/ Speed**	Maximum Load/ Speed**
African Elephant*	H ¹	680/15	1,020/10	1,360/5
Ankylosaurus*	H	660/6	990/4	1,320/2
Griffon*	L	210/12 Fl 30 (C)	315/9 Fl 20 (D)	420/4
Mammoth*	H	700/12	1,030/9	1,400/4
Polar Bear	H	530/12	745/9	1,060/4
Silver Dragon, Young	H	550/9 Fl 30 (C)	825/6 Fl 20 (D)	1,100/3
Giant Stag Beetle*	L	210/6	315/4	420/2
Subterranean Lizard*	H	630/12	945/9	1,260/4
Triceratops*	H	730/9	1,095/6	1,460/4
White Dragon*, Old	G	960/12 Fl 40 (C)	1,440/9 Fl 27 (D)	1,920/4
Wyvern	G	745/6 Fl 24 (E)	1,117/4 Fl 16 (E)	1,490/2

* Creature receives sturdy quadruped bonus

** Creature moves at the listed speed as long as its load does not exceed the listed weight, otherwise it moves at the next slower rate. Creatures loaded beyond their maximum capacity cannot move.

¹The African elephant is listed as Large in the MONSTROUS MANUAL™ accessory; however, it has been changed to a Huge creature for purposes of this table in order to bring it in line with the other creatures listed.

size; a wagon can have from one to six squares of passenger capacity.

Man-sized creatures in a normal wagon can claim 25% cover from the wagon's sides. If the wagon is covered or enclosed, it offers 50% cover. A specialized war wagon offers each passenger 90% cover.

Passengers in a wagon can fire missiles, cast spells, or make melee attacks as though stationary as long as the animals pulling the wagon do not charge, engage in melee, rout, or attempt an overrun. If the team charges, fights, or attempts an overrun, everyone in the wagon must declare a half-move action to stay inside and keep steady. If the team routs, everyone in the wagon must declare a full-move action to stay inside and can do nothing else. Passengers can try to jump out; a character who jumps out of a wagon is considered knocked down and suffers 1d6 points of damage unless he rolls a successful saving throw vs. breath weapon.

Driving Checks and Flipping Over

An unskilled chariot or wagon driver must roll an 8 or less on 1d20 to keep from flipping over in a dangerous situation. The driver can add his Armor Class adjustment from Dexterity/Agility to the required number and gets an additional +1 bonus if he also has the animal

handling proficiency. If the driver has the vehicle handling proficiency, he can make a proficiency check instead of a driving roll; the +1 bonus for the animal handling proficiency also applies to the check.

The vehicle flips over if the check fails. Everyone in the vehicle must roll a successful saving throw vs. breath weapon or be pinned underneath. A successful roll indicates that the character is thrown clear. If the vehicle is fully enclosed by a rigid structure, passengers cannot be pinned under it, but anyone inside must spend all of the next round climbing out. Passengers in an open-topped wagon (not a

chariot) get a +3 bonus to the roll. If the roll is successful, the character is considered knocked down and must spend a half-move or attack action to stand up. A pinned character remains, prone, under the vehicle for the remainder of the round and must spend all of the next round getting clear.

Ramming

Ramming occurs when vehicles (including creatures carrying howdahs) attack each other directly. A ramming attack is resolved during the attacker's movement phase.

If a vehicle attacks another vehicle, make an opposed driving roll. The following modifiers apply:

- +1 for each size class larger than the opponent;
- +1 for having more wheels or legs than the opponent.

If the defender wins the roll, one of the attacker's wheels, as determined by the DM, must roll a successful saving throw vs. crushing blow (see *DMG*, Table 29). If the roll fails, the wheel breaks and the attacking vehicle flips over. If the attacker wins the roll, one of the defender's wheels must roll vs. crushing blow as above.

Siege Warfare



If the wheel does not break, the defender still must make a driving check to avoid flipping over.

If a creature attacks a vehicle, the vehicle's driver rolls an opposed driving check vs. the creature's effective Strength score. If the creature wins the roll, the vehicle flips over. A creature cannot attack a vehicle in this fashion unless it is at least as large as the vehicle. If the vehicle wins the roll, the creature must veer away from the vehicle.

If a vehicle attacks a creature that is too large to be overrun, use the procedure outlined above. If the vehicle wins the roll, the creature must move one square, just as though it had been overrun (but the attacking vehicle inflicts no damage).

If an attacker tries to ram an unattended vehicle, use the procedures outlined above. The unattended vehicle has a default driving skill of 5.

Miscellaneous War Machines

The following weapons do not fit into any of the previous categories, yet they could very easily be found

on the battlefield.

Battering Ram

In its simplest form, a battering ram consists of a sturdy beam that one or more creatures can pick up and swing against a portal or wall to batter it down. More complex rams have beams with reinforced heads and a frame to support the beam. Any long, heavy object (such as a log or bench) between five and 30 feet long can be used as a simple ram, provided there is at least five feet of free space behind the ram (to allow the crew to swing it). A minimum of one Man-sized creature is required of each 5 feet of ram, and a maximum of two Man-sized creatures is allowed per five feet of ram. A ram can affect only portals, structures, or large, stationary objects (see the Escalades section, below).

Creatures carrying or wielding a simple ram move and defend as though heavily encumbered, regardless of the ram's actual weight.

A ram suspended from a frame can be from 10 to 60 feet long. A suspended ram allows the crew to employ its strength more efficiently, inflicting more damage.

A ram crew can swing the ram once a round, during the very slow phase.

Bore

A bore, also known as a sow, is similar to a suspended battering ram, but has a head similar to a pointed screw. The screw head is very effective against stonework. Otherwise, it functions as a suspended ram.

Cauldron

The most common form of this weapon is a huge kettle placed in a frame that allows it to tip and spill its contents on unfortunate opponents below. The same effect can be obtained by suspending a barrel, bucket, or bladder from a beam and tipping or splitting the container so that its contents spill out.

Unless otherwise noted, the contents of a cauldron pour down in a stream one square wide. When it hits the ground, it forms a puddle three squares wide and three squares long, centered on the point of impact. If there is a wall or similar barrier that keeps the pool from spreading out, the pool is five squares long and two squares wide, with the long side lying along the barrier.

The amount of damage a cauldron inflicts varies with the type of material in it:

- Flaming oil burns for two rounds, inflicting 2d6 points of damage on the first round and 1d6 points of damage on the second round;
- Boiling oil must be heated for at least one hour before use or it is treated exactly like flaming oil (once heated its temperature can be maintained as long as fuel is available). Boiling oil burns for two rounds, inflicting 4d6 points of damage the first round and 1d6 points of damage on the second round;
- Boiling water is much cheaper than boiling oil. It must be heated for 30 minutes before use. Boiling water inflicts 2d4 points of damage when it strikes a creature and 1d4 points of damage the round thereafter as it soaks into fur or clothing and continues to scald. Creatures entering the area of effect on the second round take no damage;
- Molten lead must be heated at least four hours before use, and the volume of hot liquid is generally small. Molten lead forms a puddle two squares wide and two squares long, with one square directly under the cauldron and spreading away from the cauldron to the left or right as the attacker chooses. Molten lead sears its targets for three rounds, inflicting 4d6 points of damage the first round, 3d6 points of damage the second round, and 2d6 points of damage the third round.

Chapter Eight

Gallery Shed

A gallery shed is a low structure built to protect a ram, bore, or team of sappers (see the Escalades section below). It has a peaked roof of heavy planks, it is supported by thick wooden walls, and it is usually wheeled and covered with wet hides to make it flame resistant. Gallery sheds are usually 15 to 60 feet long and five to 20 feet wide. The shed protects as many map squares as it covers. For example, a 10- by 50-foot shed protects 20 squares. Creatures within are completely hidden from view and protected from missile and melee attacks lunched from outside the shed. Creatures within the shed, however, cannot attack except to operate their ram or bore to make sapping attacks.

If the shed has no wheels, it takes one Man-sized

creature to carry it for each map square it covers. The 10- by 50-foot shed from the previous example would require 20 Man-sized creatures to carry it. Creatures carrying the shed move as though severely encumbered regardless of its weight. If the shed is wheeled, it can be pushed along as though the crew were heavily encumbered, but it cannot negotiate rough terrain or even moderate slopes.

Greek Fire Projector

Greek fire is an alchemical mixture that readily bursts into flame and burns furiously. A Greek fire projector is a metal tube about six inches wide and five feet long. When uncapped, it acts like a flame thrower, spraying a line of flame one square wide and four squares long. The line begins at the projector's mouth and extends directly away. Creatures within the area immediately suffer 3d10 points of damage unless they roll a successful saving throw vs. breath weapon for half of that. Targets suffer an additional 1d10 points of damage during the next two rounds, regardless of the initial saving throw's result.

Mantlet/Abatis

A mantlet is something like an oversized shield. It is typically made of heavy planks and is six feet high and 10 feet wide. A single figure armed with a bow or crossbow can fire through an opening in the mantlet and claim 90% cover. Additional figures firing from behind the mantlet can claim 50% cover.

A mantlet weighs 100 pounds and requires at least two Man-sized creatures to carry it. Creatures carrying a mantlet move as though heavily encumbered (due to the mantlet's bulk) even if they can handle the weight. Mantlets usually are fitted with props so the troops carrying it can set it down and use it without being encumbered.

An abatis is similar to a mantlet, but lower and thicker. It is used to

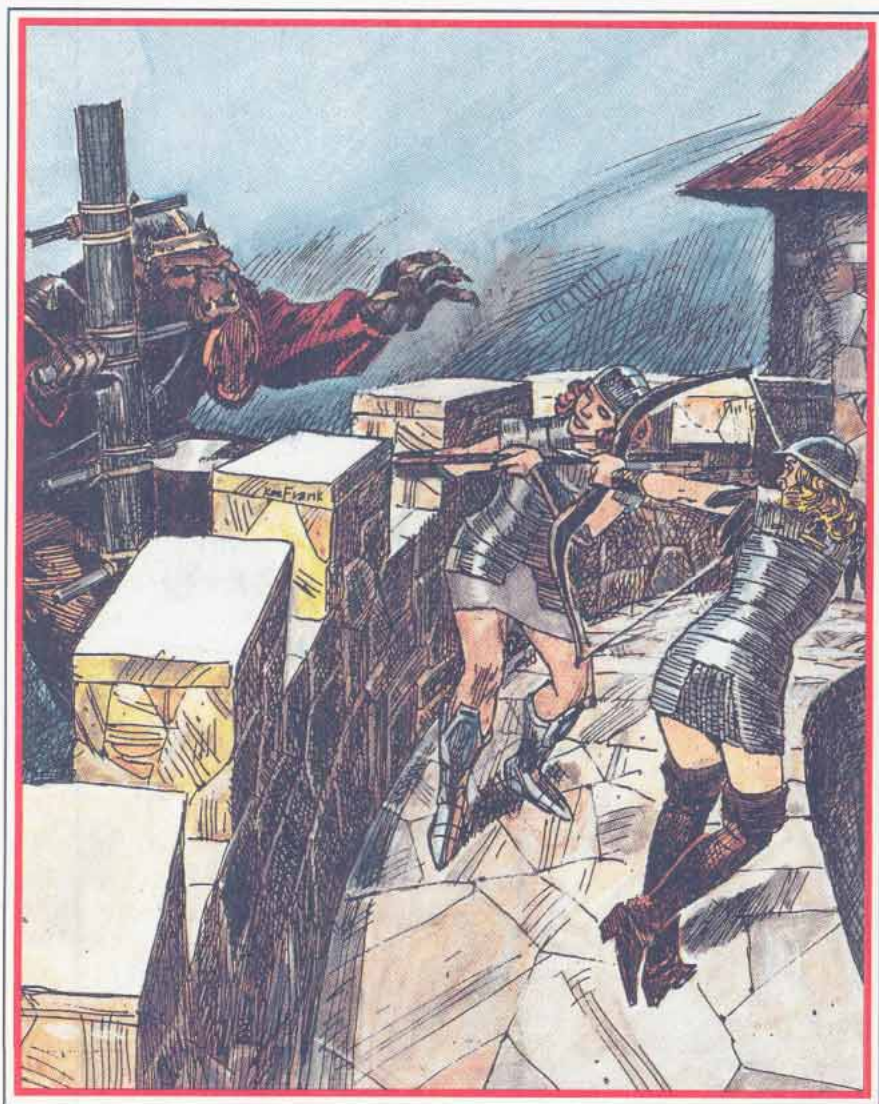

Siege Warfare



plug breeches in walls and to provide a semi-mobile barrier against foes. An abatis provides 50% cover to creatures behind it. Large-sized and smaller creatures cannot cross an abatis until it is destroyed. Giants and other Huge, bipedal creatures can cross an abatis at a cost of two movement points.

Ram Catcher

This is a large hook or fork on a long pole. Typically, it can catch and hold a ram or bore working directly below. The ram remains held, unable to attack, until the attackers break the ram catcher or kill the crew. The ram catcher is too small to be attacked by bombardment engines, but it is susceptible to attacks from slashing weapons. It has an Armor Class of 2 and 30 hit points.

Rocks

One of the most simple and effective ways to defend a wall or fortification is to hurl chunks of rock or masonry down on the attackers. The character hurling the rock makes a normal attack roll. The damage inflicted varies with the size of the rock and the distance it falls:

	Size		
	Small	Medium	Large
Knockdown Die	1d6	1d8	1d12
Distance Fallen			
<i>Short</i>	1d4	2d4	3d4
<i>Medium</i>	1d8	2d8	2d8
<i>Long</i>	1d10	2d10	3d10

Small rocks weigh less than four pounds. Medium rocks weigh more than four but less than eight pounds. Large rocks weigh eight pounds or more.

A short fall is 10 to 30 feet. A medium fall is 31 to 60 feet; the standard -2 modifier for missiles at medium range applies. A long fall is 61 feet or more; the standard -5 modifier for missiles at long range applies. Dexterity bonuses apply to the attack roll, but Strength bonuses do not (nor do Strength bonuses apply to the damage roll). Rocks are dropped on the attacker's base initiative phase.

Critical Hits and Knockdown Dice

A dropped rock inflicts Small, Medium, or Large blunt critical hits, depending on its size. All rocks add +1 to the knockdown die at medium distances and +2 to the knockdown die at long distances.

Multiple Targets

If a rock is dropped on a group all scaling the wall by the same route, ladder, or rope, the attacker makes a normal attack roll against the lead climber. Every creature below the leader must roll a successful saving throw vs. breath weapon to avoid being hit as well. The other climbers receive a +3 bonus to the save if the initial attack misses.

Siege Tower

This construction is also called a belfry. It consists of a framework mounted on wheels and covered with thick planks and a layer of hides soaked in water (to make the structure flame resistant). The whole tower is about 40 feet high. Inside, a siege tower has three stories: The ground floor is about 15 feet square. Creatures on this floor are protected as if they were in a gallery shed (see above). The second story is 30 feet from the ground. This story is equipped either with three arrow slits where troops armed with bows or crossbows can fire out with 90% cover, or a 10- to 15-foot drawbridge that can be lowered to provide quick access to the top of a wall. While the drawbridge is up, troops on the second story have 100% cover.

The third story is a partially enclosed deck about 10 feet square. Creatures on the deck have the same benefits as creatures behind a mantlet.

Six Man-sized creatures working within the bottom story can push a siege tower as though they were severely encumbered. Six more Man-sized creatures can push from behind the tower and the team of 12 can move as though heavily encumbered. Like a wheeled gallery shed, a siege tower cannot cross rough terrain or moderate slopes.

Miscellaneous War Machine Costs and Weights

Machine	Cost	Weight
Bore	500	100-600
Cauldron	50	150
Gallery Shed	250-500	400-4,900
Greek Fire Projector	500	75
Mantlet	15	100
Ram Catcher	25	25
Ram, Simple	50	50-300
Ram, Suspended	400	100-600
Siege Tower	800	2,000

Chapter Eight



Escalades Technically, an escalade is an attempt to storm a castle or fort by scaling the walls, usually with ladders. Rules for doing so are included here, but this section also includes rules for other types of actions that can take place during a **PLAYER'S OPTION** combat scenario, including combat between war machines.

The Approach of a Castle

The area around a castle usually provides clear lines of fire out to the maximum range of the castle's defensive weapons. For example, a castle equipped with light ballistae offers a clear line of fire out to 330 yards. The encounter range is always the same as the maximum missile range.

Footing around a castle varies with the terrain. A castle built on a plain has good footing. Mountain castles are surrounded by rocky slopes ($\frac{2}{3}$ or $\frac{1}{2}$ movement when going uphill), forest castles tend to be surrounded by masses of stumps where trees have been cut to provide clear lines of fire ($\frac{1}{2}$ movement).

Cover is generally not available to creatures attacking a castle once they enter maximum missile range, regardless of the quality of the footing.

A castle's walls present an obvious obstacle to attackers. In addition, castles often are surrounded by ditches or moats, usually from 10 to 20 feet deep.

Walls

One way to capture a castle or fortress is to climb the walls and overpower the defenders inside. This sort of undertaking is very dangerous, but its simplicity and speed makes it an obvious choice for small bands of heroes.

There are four basic types of castle walls in the AD&D game:

Wooden Palisades: These walls usually are made from sharpened logs about six inches thick. They typically are 10 to 15 feet tall. Defenders cannot fight from atop a palisade unless it is provided with a catwalk or hoardings (see below).

Stone: These walls are made of a single layer of stone or brick and are otherwise similar to palisades.

Curtain Walls: These walls are built of two layers of dressed stone with dirt and rubble packed in between. Curtain walls generally are thick enough to provide a fighting platform and are usually battlemented (see

below) to provide extra cover. Curtain walls are usually 30 to 60 feet high and can be from 10 to 30 feet thick.

Earth ramparts: These walls are mounds of dirt, usually carefully packed and braced. Unlike the other three types of walls, which are vertical, a rampart slopes upward at a steep angle. Defenders can fight from atop a rampart, but a stone wall, palisade, or catwalk often is added at the top to provide extra cover. Ramparts are usually 20 to 40 feet high and 40 to 80 feet thick.

Wall Defenses

A simple wall offers no cover to characters standing on it. Castle designers, however, had several ways to rectify the problem:

Battlement: This is a barrier about six feet high with alternating solid parts (merlons) and openings (embrasures). A battlement gives Man-sized creatures standing behind it 50% cover while actively defending the wall against attacks coming from below the battlement. The best cover an active defender can claim from attacks coming from the battlement's level or higher (for example, from attackers atop a siege tower) is 25%. A wall less than 10 feet thick requires a catwalk to make a battlement useful.

Catwalk: This is a narrow ledge that allows defenders to hide behind the wall. It grants 25% cover against attacks coming from below.

Embrasure Shutter: These heavy wooden shutters can be added to a battlement to increase the cover value to 75% against all attacks.

Hoarding: This wooden construction is similar to a catwalk, but it is built on the outside of the wall. It gives 90% cover to creatures attacking opponents at the base of the wall, and 75% cover otherwise. A hoarding made of stone is called a machicolation.

Splay: This is an angled area at the base of a wall. It helps support the wall, and makes it difficult for siege engines to attack the wall directly. If the defenders drop rocks from atop a wall fitted with a splay, the weapons scatter if they miss. Use the bombardment engine scatter diagram, but treat a roll of 5, 6, or 7 as a roll of 2. The rock bounces one square in the indicated direction. War machines are automatically struck and creatures must roll a successful saving throw vs. breath weapon or be struck, regardless of Armor Class.

Scaling Walls

It is possible for most characters to climb a castle's walls. See the *Player's Handbook*, Chapter 14, for basic climbing rules. Treat palisades as rough surfaces, stone

Siege Warfare



and curtain walls as very smooth surfaces, and ramparts as sloping walls (see *PHB*, Table 27). Note that climbing movement is measured in *feet* per round. Characters scaling a wall suffer a number of restrictions and penalties:

- A climber loses all Armor Class bonuses from a shield and Dexterity;
- A climber suffers a –2 penalty to attack, damage, and saving throw rolls;
- Attacks directed at a climber from the ground gain the standard +2 bonus for rear attacks. Attacks directed at a climber from atop the wall gain the standard +1 bonus for an attacker on higher ground;
- A climber struck for any amount of damage must succeed with an immediate climbing check or fall to the ground. If an attack also causes a knockdown chance or a forced retreat, the climber must make a successful saving throw roll vs. death or fall to the ground;
- A climber cannot employ a two-handed weapon.

Ladders

This is the best way for an unskilled climber to get up a wall. Carrying a ladder requires two Man-sized creatures per 10 feet of length. The carriers move as though heavily encumbered. A ladder can be put in position against a wall in the End-of-Round step of any round when it is carried to the base of the wall. A ladder must be at least as long as the wall is tall, plus five feet. A character can climb four feet of ladder per movement point each round.

Defenders atop a wall can use an attack to push a ladder away. If the ladder is not braced or loaded with climbers, the attempt always succeeds. Otherwise, the ladder falls if the defender makes a successful open doors roll. Trying to push a ladder away provokes attacks of opportunity if the defender is threatened.

When a climber reaches the top of a wall, he can step onto the wall during the round's resolution phase if there is an empty square in front of him (this could provoke an attack of opportunity). If there is no empty square, the climber must slay a defender or force a retreat and create an empty square before stepping from the ladder.

Grappling Hooks

To set a grappling hook, the wielder makes an attack roll vs. Armor Class 5, adjusted for range. It takes a full

round to hurl the hook and set it firmly or to recover the grapple after a miss.

A character climbing by means of a rope and grapple moves at the rope and wall rate and receives a bonus to his climbing chance (see *PHB*, Chapter 14).

A defender can cut the rope attached to a grapple by attacking it with a slashing weapon. The rope has an Armor Class of 5 and 5 hit points. A length of light chain can be attached to the grapple to make cutting more difficult. A chain reduces the grapple's maximum range in half. The chain has an Armor Class of 0 and 20 hit points.

War Machine vs. War Machine

A siege is a slow-moving process that can take months to resolve—not the best subject for a heroic role-playing game. However, an artillery duel or an attempt to storm a castle's walls, supported and opposed by war machines, provides lots of action for battle.

The table on the next page gives attack and defense values for all the common war machines listed in this chapter. Defensive values for some common structures are also included. Note that statistics for true fortifications are not included here—it takes more than a few combat rounds to bring down a castle wall. Rules for true sieges are given in the next section.

Fires

Wooden constructions, including most war machines (but not cannons) can be set ablaze by Greek fire, flaming oil, incendiary missiles, and the like.

Unprotected wood catches fire whenever struck by a fire attack. Wood protected by wet hides or continual soaking catches fire only on a 1–3 on 1d20. Green or freshly wet wood catches fire on a roll of 1–11 on 1d20.

The structure takes normal damage from the attack the first round. On the next round, the attacker rolls 1d20 for each point of damage inflicted in the first round; on a roll of 10 or more, one additional point is inflicted. If defenders spend the whole round fighting the fire there is more damage only on a roll of 15 or more. If no damage is inflicted, the fire goes out. The process is repeated each round until the construction loses all its structural points or the fire goes out.

Door, Common: This is a regular door made of heavy planks.

Door, Reinforced: This is a typical dungeon or castle door strengthened with metal bands and studs.

Chapter Eight

War Engine Attack and Defense Values

Weapon	Range M/S/M/L	THACO	Attack Value	ROF	Crew	Defense Value
<i>Bombardment Engines</i>						
Ballista, Light	-/11/22/33	12	—	1/8	1	4
Ballista, Medium	1/11/22/33	14	1d3	1/12	2	8
Ballista, Heavy	2/12/24/36	17	1d4+2	1/16	4	12
Bombard	18/-/-/40*	17	1d6	1/15	3	20
Bombard, Great	36/-/-/80*	19	3d12	1/18	5	30
Cannon, Light	-/15/45/90	12	1d6	1/15	3	20
Cannon, Medium	-/20/60/120	14	2d12	1/18	4	25
Cannon, Heavy	-/30/90/180	17	3d12	1/30	6	30
Catapult, Light	15/-/-/32*	14	1d2	1/8	1	10
Catapult, Medium	15/-/-/32*	15	1d3+1	1/12	3	12
Catapult, Heavy	18/-/-/36*	16	2d4	1/16	5	15
Trebuchet	24/-/-/48*	17	4d4	1/16	8	20
<i>Vehicles</i>						
Chariot, Light	-/-/-/-	—	—	—	—	8
Chariot, Medium	-/-/-/-	—	—	—	—	10
Chariot, Heavy	-/-/-/-	—	—	—	—	12
Howdah	-/-/-/-	—	—	—	—	8-12
Wagon	-/-/-/-	—	—	—	—	8-24
Wagon, War	-/-/-/-	—	—	—	—	10-30
<i>Misc. War Machines</i>						
Bore	-/0/-/-	—	1d4 ¹	1	‡	12
Cauldron	-/0/-/-	—	†	1/20 ²	2	12
Gallery Shed	-/-/-/-	—	—	—	—	20
Greek Fire Projector	-/0/-/-	—	††	1/16	2	8
Mantlet/Abatis	-/-/-/-	—	—	—	—	12
Ram Catcher	-/0/-/-	—	1d2 ³	—	2	—
Ram, Simple	-/0/-/-	—	1d2 ¹	1	‡	6
Ram, Suspended	-/0/-/-	—	1d4 ¹	1	‡	12
Siege Tower	-/-/-/-	—	—	—	—	24
<i>Other</i>						
Door, Common	-/-/-/-	—	—	—	—	8
Door, Reinforced	-/-/-/-	—	—	—	—	16
Gate/Portcullis	-/-/-/-	—	—	—	—	32-64
Ladder	-/-/-/-	—	—	—	—	4
Wall, Brick	-/-/-/-	—	—	—	—	25
Wall, Thick Wood	-/-/-/-	—	—	—	—	15
Wall, Light Wood	-/-/-/-	—	—	—	—	10
Rock, Small	-/0/-/-	—	0/0/1	1	1	—
Rock, Medium	-/0/-/-	—	0/1/1d2	1	1	—
Rock, Large	-/0/-/-	—	1/1d2/1d4	1	1	—

* Indicates that the usual -5 modifier for long range shots does not apply.

† The material loaded into a cauldron determines damage. Boiling water inflicts no damage on structures. Boiling and flaming oil inflicts 1d4 points of damage to wooden structures on each of the two rounds it burns; if the structure catches fire during the first round, the extra damage is added during the second round. Molten lead inflicts 1d4+1 points of damage to wooden structures each round it sears.

†† Greek fire inflicts 2d4 points of damage to wooden structures each round it burns. If the structure catches fire during the first round, the extra damage is added during the second round.

‡ Simple rams require a crew of at least one Man-sized creature per 5' of length; the maximum crew is two Man-sized creatures per 5' of length. Suspended rams and bores require a crew of at least two Man-sized

creatures per 10' of length; the maximum crew is four Man-sized creatures per 10' of length.

¹ Per two Man-sized crew members. Bores add +1 to each die of damage if the target is stone. A simple ram crewed by a single Man-sized creature inflicts 1 point of damage.

² This is the time required to reposition and reload the cauldron. Time required to heat the contents is not included.

³ Per two Man-sized crew members. There must be at least two crew operating the ram catcher for every 10' of ram or no damage is inflicted. If the ram is protected by a gallery shed, there must be at least four crew members per 10' of ram.

⁴ Indirect fire engines usually cannot target portals, as the missiles tend to strike the wall containing the portal instead.

Siege Warfare



Gate/Portcullis: This refers to large portals for admitting vehicles and mounted troops. A gate is double valved and made from heavy planks or metal bars. A portcullis is a metal grillwork. Drawbridges also fall into this category.

Ladder: A typical ladder is made from a pair of half-inch rails with rungs about the same size lashed on.

Walls: Values given are for a section 10' square.

Brick: This includes walls made from fired brick, tile, adobe, or soft stone about six inches thick. Hard stone such as granite has twice the structural value.

Thick Wood: This includes walls made from rough hewn logs or heavy timbers.

Thin Wood: This includes walls made from ordinary planks, wattle and daub, and similar lightweight materials.

Rocks: The first number indicates structural damage inflicted when the rock is dropped a short distance. The second number indicates a medium drop, and the third number indicates a long drop. Structures and war machines have an Armor Class of 10 when attacked by rocks.

Sapping

Teams of four Man-sized creatures can inflict 1d2 points of structural damage each round if armed with picks, crowbars, or weapons that can serve as picks or crowbars. Teams of less than four creatures also can inflict structural damage, but there is a one-round delay for every creature missing. For example, a team of three humans could inflict 1d2 points of structural damage every two rounds. Sapping is a no-move action that occupies a creature for the entire round.

Two Small or four Tiny creatures count as one Man-sized sapper; one Large creature counts as two Man-sized sappers, one Huge creature counts as three Man-sized sappers, and so on. Burrowing creatures inflict triple damage dice. For example, a single umber hulk (a Large burrowing creature) inflicts 3d2 points of damage every two rounds.

Petards

A petard is an explosive charge placed against a wall or portal in an attempt to blow it open. Generally gunpowder or *smoke powder* is the explosive. Every 10 charges of powder inflicts 1d4 points of structural damage to the target.

Creatures Inside Destroyed Targets

Defenders inside a structure that is destroyed (loses all its structural points) must roll successful saving throws vs. death or be killed in the collapse. Success indicates 2d6 points of damage.

Magical Attacks

The following spells and magical items can be useful during an escalade:

Bigby's Clenched Fist

A blow from this spell inflicts 1d4 points of structural damage. The disembodied hand is a Man-sized target.

Dig

This spell allows the caster to dig through earth ramparts at the rate given in the spell description. If a hole dug through a rampart collapses, the area above it becomes damaged (see the Sieges section, below).

Disintegrate

Because this spell obliterates a 10' cube of nonliving matter when it strikes, most war machines and portals are effectively destroyed when struck. If the DM decides a target is not destroyed, it still suffers 2d10 points of structural damage—and has a 10' hole in it.

Earthquake

Buildings suffer 5d12 points of structural damage from this spell. The spell also caves in mines and tunnels and can cause the ground to crack open and swallow up war machines as though they were Large creatures. Siege towers have a 50% chance to fall over even if they do not fall into a crack.

Fireball

This spell inflicts 1d2 points of structural damage against wooden targets (including those protected by wet hides) for every two dice of damage it normally inflicts; round fractions down. For example, a *fireball* from a 5th-level caster inflicts 2d2 points of structural damage. A *fireball* can set wooden constructions afire.

Horn of Blasting

A blast from this item inflicts 4d4 points of structural damage against stone or metal targets and 6d4 points of structural damage against wooden targets.

Chapter Eight



Incendiary Cloud

This spell does not harm structures or war machines directly, but it can set fire to wooden constructions during the fourth round of its existence. Roll for a fire once for each level of the caster.

Lightning Bolt

This spell damages wooden constructions just as a *fireball* does. It inflicts 1d2 points of structural damage against stone or metal targets for every three dice of damage it would normally inflict; round fractions down. For example, a *lightning bolt* from a 7th-level caster would inflict 3d2 points of damage against a mantlet (a wooden target) and 2d2 points of damage against a portcullis (a metal target). A *lightning bolt* can set wooden constructions afire just as a *fireball* can.

Potion of Fire Breath

The tongue of flame from this potion can damage wooden constructions. It inflicts 1d2 points of structural damage for each die of damage it normally inflicts. For example, a single draught inflicts 1d2 points of structural damage. It also can set wood constructions afire.

Mattock of the Titans

This item can be used to bore through ramparts or walls at the listed rates, similar to a *dig* spell, except that it can also bore through stone.

Maul of the Titans

When employed against small constructions or war machines, this item inflicts 2d8 points of structural damage.

Move Earth

This spell can collapse ramparts (or sections of ramparts) up to 240 yards long and up to 60 feet thick. A rampart collapsed in this manner is treated as damaged; if less than a third of its original volume remains, it is considered destroyed (see the Sieges section, below). A rampart can be made resistant to *move earth* spells by facing it with brick or stone or bracing it internally with timbers or stone. A rampart reinforced in this manner resists a *move earth* spell on a roll of 10 or higher on 1d20. If the rampart is faced *and* internally braced, it is immune to *move earth* spells.

Ring of the Ram

This item inflicts 1d4 points of structural damage per charge expended.

Ring of Shooting Stars

This item's *ball lightning* effect inflicts structural damage as a *lightning bolt* spell does. If multiple balls are discharged against the same target in a single round, total the normal damage dice before calculating the structural damage dice. For example, if the wearer creates two balls of lightning (5d4 points of damage each) and directs them both at a single target, the balls would inflict 5d2 points of structural damage against a wooden target or 3d2 points of structural damage against a stone or metal target.

Transmute Rock to Mud

This spell effects only "natural" stone. Stone which has been created or protected by magic is unaffected, as is stone which has been artificially shaped on all four sides. For example, the walls in a simple tunnel driven through solid rock are subject to this spell, but if the tunnel were lined with brick or stones that had been worked into blocks, a *transmute rock to mud* spell could not harm them. This spell still is very useful in a siege, however, as virtually all castles must be built upon bedrock in order to support the weight of the walls. It is possible to use a *transmute rock to mud* spell to undermine a wall by attacking the bedrock underneath, provided that the spell has enough area to reach under the wall and that the mud can flow out and leave a cavity under the wall. In some cases it might be necessary to employ sappers or a *dig* spell to get at the bedrock and provide a place for the mud to go. If these conditions are met, the wall still remains unaffected if the defender rolls a 10 or more on 1d20.

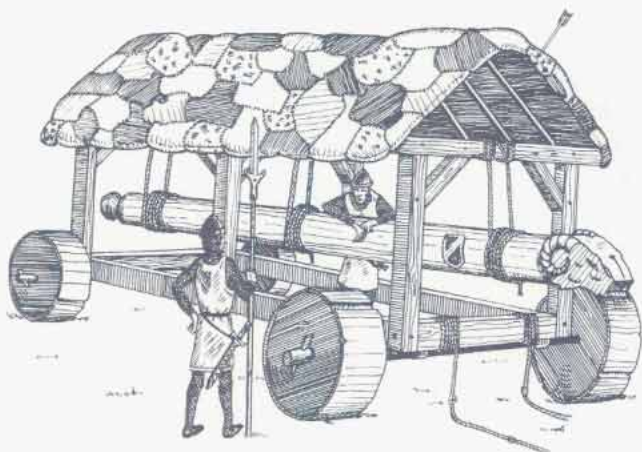

Siege Warfare



Reduction

Attacker	Defending Wall Type				
	Hard Stone	Soft Stone	Earth	Thin Wood	Thick Wood
Ballista, Medium	—	3/Month	—	10/Day	5/Day
Ballista, Heavy	3/Month	4/Month	—	11/Day	6/Day
Bombard	5/Week	9/Week	7/3 Months	20/Immediate	16/Day
Bombard, Great	7/Week	11/Week	9/3 Months	20/Immediate	20/Day
Bore	9/Hour	11/Hour	—	12/Immediate	12/Day
Cannon, Light	5/Week	9/Week	7/3 Months	20/Hour	20/Hour
Cannon, Medium	6/Week	10/Week	8/3 Months	20/Immediate	20/Day
Cannon, Heavy	7/Week	11/Week	9/3 Months	20/Immediate	20/Day
Catapult, Light	2/Month	6/Month	4/3 Months	20/Day	13/Day
Catapult, Medium	3/Month	7/Month	5/3 Months	20/Immediate	14/Day
Catapult, Heavy	4/Month	8/Month	6/3 Months	20/Immediate	15/Day
Ram, Simple	7/Hour	9/Hour	—	20/Hour	20/Day
Ram, Suspended	8/Hour	10/Hour	—	20/Immediate	20/Hour
Mine	10*	10*	8*	10*	10*
Trebuchet	5/Month	9/Month	7/3 Months	20/Immediate	16/Day

*Each attempt to mine is a one-time attempt. See Mines for more information.

Reduction

This refers to any attempt to destroy a castle's walls. Use the table to resolve the attempt.

Attacker: The type of engine attacking the wall. This assumes one engine attacking each 30' section of wall.

Defending Wall Type: This refers to the wall types described in the Escalades section. Curtain walls are treated as hard or soft stone, depending on the materials used to construct them. Ramparts

Wall of Fire

This spell can set fire to wooden structures as mentioned in War Machine vs. War Machine, above, if it is placed against them. Roll for a fire once for each level of the caster. If a wooden construction passes through a wall of fire, it suffers 1d3 points of structural damage plus one point per caster level and can start a fire as noted above.

Wall of Iron

A plain iron wall created by this spell has five structural points per ¼ inch of thickness.

Wall of Stone

A plain stone wall created by this spell has two structural points per ¼ inch of thickness.

Warp Wood

Wooden bombardment engines and wheeled vehicles are disabled if affected by this spell. Doors and walls suffer 2d8 points of structural damage.

Sieges Sieges are ponderous affairs that involve a lot of waiting and general inactivity. The attacker's main goal is to batter down the defending walls so they can launch an escalade or to drive the defender out through starvation or thirst. The following system allows you to simulate the effects of an extended siege, handling months of operations with a single die roll.

are treated as earth. Palisades are treated as thick wood. Normal buildings, mantles, and abatises are treated as thin wood. Note that ramparts are difficult to batter down but fairly easy to climb.

Reduction Procedures

Cross reference the type of attacker with the type of defending wall. The number before the slash indicates the saving throw, rolled on 1d20, the wall needs to resist the attack. The time period after the slash indicates the amount of sustained attack there must be before the die is rolled; "immediate" indicates that the wall must save every time it is struck. For purposes of these rules, one "day" represents about 10 hours of sustained bombardment. If the crews are relieved (and they can see their targets) it is possible to perform two shifts of bombardment every 24 hours. If more than one engine is attacking the same section of wall, roll once for each engine. The saving throw numbers assume a wall of average strength and thickness for its type. If the wall is unusually well made (a dwarven fortress with exceptional stone, for example), the DM can allow a saving throw bonus of +1 or +2. Furthermore, an exceptionally thick wall gains a saving throw bonus of +1 for every 50% of extra thickness. A curtain wall 45 feet thick, for example, would gain a +1 saving throw bonus.

Saving Throw Failure

If a wall section fails its saving throw once, it becomes damaged. The center 10-foot section loses ⅓ of its

Chapter Eight

height and special cover such as hoardings, parapets, and splays are destroyed. The debris creates a crumbling slope that any character can attempt to climb. If a wall section fails its saving throw twice, it is destroyed. The center 10' section is breached and reduced to $\frac{1}{2}$ of its original height. The breach becomes a rocky slope as long as the wall's original thickness. In addition, the 10' section to either side of the breach becomes damaged. If the defenders have an abatis prepared they can move it into position immediately. An abatis saves as thin wood.

For example, an attacking army brings three heavy cannons to bear against a fortress with granite curtain walls 50' thick and 45' high. The walls save as hard stone and receive a +1 saving throw bonus for their thickness. The DM assigns them an additional +1 due to superior workmanship (a gang of storm giants working under a dwarven engineer built the castle).

The attackers aim all three of their cannons at one section of wall. At the end of one week, the defender rolls three saving throws. The rolls are 5, 9, and 20. All the rolls are successes and the attackers make no headway the first week. Assuming that the defenders do not sally forth to knock out the cannons, they continue their bombardment for another week.

At the end of the second week, the defender rolls three more saving throws. The rolls are 3, 4, and 11; two of the rolls are failures. The center of the 30' section of wall is reduced to a rocky slope 15' high, 10' wide, and 50' long. In addition, the 10' sections of wall to either side of the breach are damaged and reduced to sloping walls 30' high. Any special features on the damaged sections, such as hoardings, are destroyed.

Mines

Attackers who found a castle's walls too difficult to batter down often attempted to undermine them by digging a tunnel underneath the walls and collapsing it, either by burning out the supports or filling the mine with powder and blowing it up. The main factor in mining is the amount of time required to dig. The following table gives the volume, in cubic feet, that a team of 10 miners can excavate in a single eight-hour shift:

Race of Miner	Earth	Soft Stone	Hard Stone
Gnoll, halfling, human	150	100	50
Gnome, kobold	160	120	60
Goblin, orc	170	130	60
Dwarf, hobgoblin	180	140	70
Ogre	300	200	100
Hill giant	600	400	200
Fire giant, frost giant	600	400	200
Stone giant	1,000	700	350

If a creature is not listed, pick the most appropriate type from the table. For example, elves mine at the human rate. The mine tunnel must be a minimum of 5' square plus an additional 5' for each size class beyond Small. For example, humans, orcs, and dwarves require a shaft 10' square. Stone giants require a tunnel 20' square.

When the mine reaches the wall, a gallery must be dug out underneath. The gallery must be as long as the wall is thick, at least 10' wide, and at least 5' deep (more if the miners require a larger tunnel). Once the gallery is dug the supports can be fired and the 10' section of wall above the gallery must roll the listed saving throw or be destroyed; if the save fails, the adjoining 10' wall sections become damaged.

The gallery can be more than 10' wide, and an additional section of wall must make a saving throw for every extra 10' of gallery width. Smoke powder or gunpowder placed in the mine can reduce the wall's saving throw. Twenty charges of powder reduce one section's saving throw roll by -1.

Counter Mining

If the defenders suspect the attackers have begun a mine, they can attempt to dig their own tunnel and attack the miners. Given general knowledge of an approaching mine's position (such as which wall the mine is aimed at) a counter mine is successful on a roll of 10 or better on 1d20. This chance can fall to nothing (if the defenders are completely fooled about the mine's location) or be an automatic success (if the defenders know where the mine is through divination magic or reconnaissance). When a counter mine succeeds, the two parties must fight a melee to see who controls the tunnels. Miners usually wear no armor and can carry only small weapons, but troops sent in to guard the miners or launch a counterattack can be armed and armored normally.

Siege Warfare



Investment

Another and generally more reliable method for capturing a castle or fort is to simply surround it and wait for the garrison to starve (assuming that the castle does not have resident priests who can keep the troops fed). The DM must decide in advance how much food is stored inside the castle. Generally, castles have no more than a year's worth of supplies on hand, and they usually have much less, perhaps several weeks' to a few months' worth.

A garrison's morale rating drops by 1 when it runs out of food. Each week thereafter, roll 1d4 for every 10 creatures in the garrison; on a roll of 4, single-Hit-Die creatures in the group expire and other creatures lose 25% of their hit points. Do not roll for player characters and important NPCs; instead, they are allowed a saving throw vs. wands with a -5 penalty to avoid the hit point loss.

The garrison also checks morale each week without food. Failure indicates that the troops open the gates to the attackers. If prevented from opening the gates, the troops attempt to leave the castle any way they can. If the morale check succeeds, the garrison holds out another week. Repeat the procedure until all the defenders starve, their morale breaks, or relief arrives.

Most castles have adequate sources of water, usually a well inside the walls. If a garrison is deprived of water, use the procedure given above for food but check for casualties, hit point losses, and morale every three days.

Mass Combat Occasionally, battles will arise that are just too large to play out with the **PLAYER'S OPTION** combat system. For example, it can take a long time to resolve a battle when 40 goblins attack the PCs as they negotiate with a dwarven lord and his 15 bodyguards.

You can use the mass combat rules whenever you feel they are necessary. Generally, if there are more creatures in the battle than will fit on your map, it's a good time to use the mass combat rules. It's usually best to leave PCs and important NPCs in place on the map and use the normal combat system to resolve their actions. Use the mass combat rules to determine the outcome of the larger battle raging around the PCs.

Mass Combat Procedures

Keep paper and pencil handy to keep track of the troops on both sides.

Start by dividing the opposing forces into groups of a

convenient size; groups of 5, 10, or 20 usually work the best. If there is an odd number of troops, make one group shorthanded. For example, a group of 35 creatures could be divided into three groups of 10 and one group of five or seven groups of five. It is best to keep groups of similar creatures together.

Assign each group an Armor Class based on the most prevalent AC in the group. For example, if a group of 20 halflings included three leaders in chain mail and 17 archers in leather armor, the group has an Armor Class of 8. If there is a tie for the most prevalent armor type, use the worst one. Assign each group a THACO based on the most prevalent THACO in the group, as above.

Once you have assigned an Armor Class and THACO to each group, you are ready to begin. You may choose to roll for surprise, allowing one group to attack unopposed, but after this combat is considered simultaneous. Assign one side of the combat to be the attackers, and one side to defend. Line up attacking groups against defending groups on a one-to-one basis. Each defending group must be attacked once before any defending group can be attacked twice. For example, a force of 60 orcs divided into six groups of 10 are attacking 40 dwarves divided into four groups of 10. Two groups of dwarves are attacked once, and two groups are attacked twice. The orcs can't attack one group six times. Note that in some cases only part of an attacking force can get into a battle. A force of 20 dwarves guarding a cave mouth might hold out against hundreds of orcs because only 20 of them can attack at a time.

The attacking group makes a normal attack roll. If the roll succeeds, they will inflict one Hit Die on the defenders for each creature in the attacking group, ignoring critical hits; however, do not remove any casualties yet.

Now, reverse the process, having the defenders return the attack, using the same procedure. When both sides have made all of their attack rolls, mark off enough casualties in wounded groups to account for all the Hit Dice inflicted, leaving only one wounded defender. For example, if a group of 10 orcs successfully attacks 10 3rd-level dwarves, three dwarves are killed and one loses a single Hit Die.

Repeat this procedure until one side is killed or breaks morale. Apply subsequent hits to wounded creatures first.

To save time toward the end of a combat, you can reorganize survivors into new groups.

Creatures "killed" in a mass combat are allowed a saving throw vs. death if they receive some form of

Chapter Eight



healing immediately after the battle. These figures are assumed to be hovering at death's door (see Chapter One) and can be saved. If there are a lot of casualties, roll the saving throws in groups of 5, 10, or 20.

An Example of Mass Combat

The dwarven leader and bodyguards from the example at the beginning of this section are talking to a group of six PCs when 40 goblins attack. The 15 bodyguards are 4th-level fighters with battle axe specialization (adjusted THACO 16), wearing *chain mail +1* and carrying shields (AC 3). The goblins have a THACO of 20 and an Armor Class of 6. They are armed with short swords and short bows.

The DM decides to divide the combatants into groups of five, so there are eight groups of goblins and three groups of dwarves. The DM also decides that all the bodyguards will join the mass combat, leaving the PCs and two groups of goblins to fight a normal PLAYER'S OPTION combat system battle. The goblins gain surprise, and loose arrows. The ten goblins fighting the PCs attack individually. The remaining six groups attack the bodyguards, two groups of goblins against each group of dwarves.

The goblins fire two volleys of arrows from 10 yards away. They are at short range and receive a +1 to their attack rolls because of surprise. Each group of dwarves receives four volleys of arrows (two groups of goblins each firing two volleys). Against the first group, the attack rolls are: 3, 17, 18, and 18; three hits. The first group of dwarves suffers 15 dice of damage; three dwarves are killed and one suffers three dice of damage. The attack rolls against the second group are 6, 17, 13, and 20; two hits. The second group suffers 10 dice of damage, killing two dwarves and inflicting two dice of damage on a third. The attack rolls against the third group are 3, 19, 4, and 14; one hit. One dwarf is killed and a second dwarf suffers one die of damage. There are no return attacks from the PCs and dwarves, because they were surprised.

The next round, the PCs and the dwarven leader fight a normal battle against their 10 foes. They make short work of the goblins, killing seven of them.

In the mass combat, the dwarves are now in the thick of the fight, charging at the goblins. The dwarves have a +2 bonus for the charge and an additional +1 because they are dwarves attacking goblins. The goblins are still firing their bows, and loose a volley of arrows as the dwarves charge. They receive a +1 bonus to their attack rolls because their opponents are charging.

The dwarves complete their charge. Each group of dwarves attacks one group of goblins, while the remaining three groups are not attacked. Their attack rolls are 16, 14, and 13; three hits. The first group contains two dwarves who inflict two dice of damage and kill two goblins. The second group contains three dwarves, and they kill three goblins. The final group contains four dwarves, who kill four goblins.

Each group of dwarves is attacked twice. The rolls against the first group are 3 and 18; one hit. The first group suffers 5 dice of damage; the wounded dwarf (who had already suffered three dice of damage) is killed and another dwarf is killed as well, wiping the group out. The rolls against the second group are 5 and 11; both misses. The rolls against the third group are 20 and 14; one hit. The wounded dwarf is killed and a second dwarf suffers two dice of damage.

The goblins wisely decide to withhold their second volley of arrows, and the dwarves get no attacks of opportunity.

Because there are only six dwarves left, the DM decides a morale check is in order, and the dwarves pass it. The DM also decides to re-combine the survivors into a single group of six. The goblin casualties result in 21 goblins remaining, which the DM divides into three groups of five and one group of six. The DM also decides that the group of six goblins leaves the mass combat to attack the PCs and dwarven leader, leaving three groups of goblins in the mass combat. (There are now nine goblins in the normal combat.)

During the next round, the PCs continue to do well, slaying seven more goblins. The two survivors fail a morale check and flee the field.

In the mass combat, the dwarves get two attacks this round, since they are specialists. The dwarves first attack roll is a 17, and six HD worth of goblins would be killed. This is enough to wipe out an entire group of goblins, but the sixth Hit Die will be wasted. The second attack is made against a second group of five goblins, and the roll is a 10; still good enough to hit the goblins' Armor Class of 6. Five more goblins will die, and the last Hit Die goes to waste.

The three groups of goblins attack, rolling 20, 12, and 4; one hit. The attack kills two wounded dwarves (who each were two HD down) and wounds another for one die of damage.

There are now five goblins facing the six PCs, the dwarven leader, and the four surviving guards. Finding themselves outnumbered, the goblins check morale and pass, not wanting to flee from their hated dwarven enemies.

Siege Warfare



The DM decides that the remainder of the battle can be handled using the normal rules, and the mass combat ends. The PCs and dwarves win handily. The 11 fallen dwarves receive magical healing and first aid as soon as the battle ends. Each rolls a saving throw vs. death to see if they can be revived. The rolls are incredibly bad, and only four dwarves survive. The PCs also revive one goblin for interrogation.

Proficiencies

The following proficiencies are applicable to warfare and the operation of war equipment. They are acquired the same way standard *PHB* proficiencies are.

Artillerist (1 Slot)
Group: Warrior

Charisma/Leadership

A character with this proficiency can direct the siting and operation of a bombardment engine. The maximum number of engines the character can control is equal to $\frac{1}{2}$ of the character's Charisma/Leadership score, provided that the engines are no farther apart than the character can sprint in a single round.

Vehicle Handling (1 Slot)
Group: Warrior

Dexterity/Dodge

This proficiency allows the character to control a wagon or chariot under difficult circumstances. The character can roll against this proficiency when a driving check is normally required.



Chapter Nine: Monsters



Monsters are the meat and drink of a fantasy campaign. The ability to defeat fearsome beasts is what sets great heroes apart from ordinary mortals. This chapter contains information on using monsters in PLAYER'S OPTION games.

There are three parts to this chapter. The first part, *Creatures in Battle*, discusses how monsters generally behave on the battlefield, using basic AD&D game information such as alignment, intelligence, and morale as a guide.

The second part, *Creature Types*, discusses the physical characteristics of monsters, including tactics and combat options that are especially applicable to particular types of monsters and how to determine what happens when a monster suffers a critical hit.

The third part, *Attack and Armor Types*, discusses the natural weaponry and protection available to monsters and how it functions in the PLAYER'S OPTION game.

Does This Belong in My Campaign?

The amount of material from this chapter you need to use depends on how much of the optional material from the previous chapters you are using. The first two sections should prove helpful to anyone using the PLAYER'S OPTION combat system from Chapter One. The last section deals primarily with optional material from the rest of this book.

Monsters



Creatures in Battle

All creatures do not fight in the same manner. A creature's instincts, natural weaponry, bravery, and culture all have an impact on the way it fights. A great wyrm red dragon is not only vastly more powerful than a kobold, its titanic intellect and vast experience makes it a more complex and unpredictable opponent than a mere kobold could ever be.

Intelligence

Creatures tend to fight as cleverly as they can, and a creature's intelligence is what determines how clever it can be:

Non- (0)

The creature just reacts to what its senses tell it. It is not capable of assessing the dangers it faces or the rewards it stands to gain. In a fight, a nonintelligent creature turns its attention to the most immediate threat. When badly hurt, a nonintelligent creature usually flees, but some creatures just don't know when they're hurt and fight on, ignorant of any danger. Nonintelligent creatures' combat actions usually are limited to attack or charge. If they flee, they run or sprint rather than withdraw. They do not employ any of the special battle tactics or attack options presented in Chapter One.

Animal (1)

The creature has a limited ability to assess risks and rewards. Generally, it responds only to very basic motivations and does not attack unless it is trained to, it is hungry, or it is defending something it values (such as food, offspring, a mate, or hunting territory). In a fight, an animal intelligence creature relies on its instincts. It attacks the most accessible opponent, the opponent that is most likely to be edible, or the opponent that scared it into attacking. The creature has some grasp of tactics, enough to know that flank attacks are better than frontal attacks and that rear attacks are better than flank attacks. The creature also instinctively understands the value of not being detected prior to its attacks.

Animal intelligence creatures usually flee if badly injured, but can fight to the death if trapped or cornered. An animal intelligence creature's combat actions can include attack, charge, guard (such as a cat waiting at a mouse hole), run, and sprint. Like nonintelligent creatures, they do not use battle tactics or attack options.

Semi- (2-4)

The creature has some ability to assess risks and rewards and is smart enough to delay an attack until a good opportunity presents itself. It is capable of learning something about its opponents' abilities. A lion or tiger, for example, knows enough to stay downwind of creatures that depend on scent and to stay behind creatures that depend on sight. With experience, the creature probably can learn to recognize missile and melee weapons and to direct attacks at lightly armed characters. If the creature has encountered missile weapons, it learns to recognize the value of cover. Otherwise it is limited to attacking, charging, guarding, running, and sprinting.

Low (5-7)

The creature relies more on experience and reasoning than instincts. It is generally aware of risks and rewards. It can make simple plans and can employ any attack option that it is equipped to use. For example, a low intelligence creature can employ missile weapons, but only if they are available. Most battle options are still beyond the creature's grasp, but it can make unarmed attacks, ride a mount, and maybe join a spear hedge or shield wall (see Chapter One).

Average-Very (8-12)

The creature might occasionally act from impulse, but generally relies on reasoning and observation to make decisions, and it can think beyond the obvious. The creature has a good appreciation of risks and rewards, but this is limited by its experience. It is capable of planning and organizing its actions and coordinating them with others. The creature can use any of the attack options, battle tactics, and combat options presented in Chapter One.

High-Exceptional (13-16)

The creature generally is not impulsive. In battle, it thinks ahead and considers how its current actions might affect its options in the future. The creature is very flexible, and can alter its tactics to fit an unforeseen situation. The creature can use any of the attack options, battle tactics, and combat options presented in Chapter One.

Genius-Supra Genius (17-20)

The creature is very insightful and almost never impulsive. It plans for the future and always carefully measures risks against rewards. Any scheme or subterfuge it

Chapter Nine



employs is apt to be hard to detect and very deadly.

Godlike (21+)

The creature can make correct deductions from incomplete information. It invariably knows the most appropriate action to take in any situation. (Though it might not always take it; godlike beings are hard to understand.) To reflect the creature's superior intellect, the DM might decide to make the PCs declare their actions before deciding what the creature does in a given combat round.

Alignment

A creature's beliefs and expectations can influence the way it fights, especially if it has at least average intelligence.

Chaotic

The creature tends to think of itself. It does not respond well to leadership unless intimidated or persuaded to

follow orders. Its tactics are usually intended to improve its individual effectiveness and survival, not the group's.

Chaotic creatures are apt to seek quick and dramatic results and combat, and are likely to employ called shots, offensive disarms, and shield rushes.

Neutral

The creature is as likely to consider the needs of the group as much as itself, so long as it can serve one without compromising the other. The creature responds moderately well to leadership, so long as it does not feel its needs are being subordinated to the group's. The creature has no great desire for individual glory.

Neutral creatures are apt to seek ways to restrict an opponent's options and to counter opposing actions, and are likely to employ parries, blocks, pull/trips, and defensive disarms.

Lawful

The creature tends to think of its group. The creature responds well to leadership, providing it is not inept, ineffective, or unnecessarily harsh. The creature generally functions as a cog in a larger machine, promoting a common goal it shares with its companions.

Lawful creatures are apt to choose tactics that rely on the group, such as shield walls, pike hedges, and massed overbearing attacks.

Morale

A creature's morale score measures its ferocity, perseverance, and courage. Though most frequently used to decide if a creature runs away or surrenders during a fight, morale also can serve as guideline for deciding the creature's general willingness to fight.

Unreliable-Unsteady (2-7)

The creature is most likely to deal with a threat by running away or hiding unless it has been trained for war or it has been cornered. If forced to fight, the creature does not purposefully do anything that exposes it to increased danger.

Average-Steady (8-12)

The creature is not so skittish as to flee at the first sign of a threat. If it does not wish to fight, it is likely to bluff or stand its ground before taking flight. The creature is not aggressive and is unlikely to make an unprovoked attack unless it is hungry or otherwise stands to gain

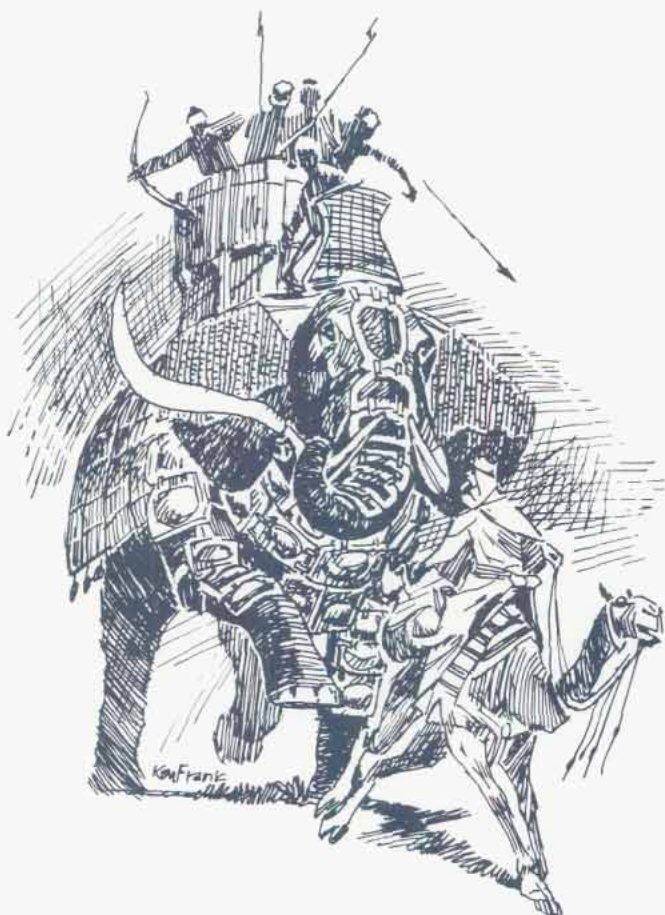

Monsters



from a fight. It is unlikely to make a frontal attack when outnumbered or outsized; if sufficiently motivated, the creature might wait for an opportunity to attack when it has an advantage over an otherwise superior group. Once a fight begins, the creature is willing to try almost anything that will improve its chances for victory, provided the risk does not exceed the potential reward.

Elite-Champion (13–16)

The creature is aggressive and generally tries to bluff its way out of fights it does not want. If the bluff fails, the creature is more likely to fight than run away. If faced with a superior force, it almost always looks for ways to even the odds before attacking. After a fight begins, the creature is willing to undertake considerable risks to help insure a victory.

Fanatic-Fearless (17+)

The creature is very aggressive. It does not bluff, preferring to attack when threatened. Once engaged in a fight, it seldom retreats. It is willing to take almost any risk to gain a victory.

Creature Types

A creature's physical characteristics also play a role in how it acts on the battlefield. If you are using Critical Hits System II from Chapter Seven, a monster's body type also determines what critical hits chart to use and what kinds of special damage can affect it.

Many basic types of creatures are described below, but you must use your own judgement and common sense when deciding a monster's type. Study the creature's statistics and description. If there is a picture, study that, too.

Humanoid

Humanoid creatures have two arms, two legs, and a head. The creature walks upright and generally uses tools and weapons. In most respects, the creature functions just like a player character, and is subject to all forms or critical hits and their special effects.

Human

The creature is Man-sized or smaller: humans, dwarves, elves, orcs, kobolds, hobgoblins, and thri-kreen are examples of human type creatures.

Critical Hits: Use the humanoid charts. If the creature has multiple arms or legs, the limbs actually involved in

the combat or closest to the attack are the most likely to be struck. Roll 1d6; a roll of 1–5 indicates that the active limb is struck, and a roll of 6 indicates the inactive limb is struck. If the creature is employing all its limbs, there is an equal chance for any limb to be struck. For example, an unarmed thri-kreen is fighting with all four claws and its opponent rolls a left arm critical. The two arms on the thri-kreen's left side are equally likely to be hit (roll 1d6 to determine which one). However, if the thri-kreen was using a weapon in one right hand, a shield in one left hand, and holding equipment in its remaining two hands, a left arm critical would most likely strike the shield arm.

Combat: Human types use attack options, battle tactics, and combat options as their intelligence ratings allow.

Ogre

The creature is larger than Man-sized, but not Huge: ogres, gnolls, bugbears, minotaurs, and quaggoths are examples of ogre type creatures.

Critical Hits: Use the humanoid charts.

Combat: Ogre types use attack options, battle tactics, and combat options as their intelligence ratings allow. They often employ tactics that exploit their superior size and reach, such as moving back out of melee range to force an opponent to close again while the creature guards.

Giant

The creature is Huge or larger: the various races of giants, giant-kin, titans, and some genies are examples of giant type creatures.

Critical Hits: Use the humanoid charts, but most opponents are forced to attack low (see Chapter Six).

Combat: Most giant types are fond of overrunning opponents, especially if they are two or more size classes larger (see Chapter One); a giant is likely to create a great deal of havoc when overrunning an entire formation of dwarves. Overrunning can be a dangerous tactic, however, and intelligent or experienced giants usually only try it early in a battle, when they have enough hit points to withstand the attacks of opportunity they are likely to provoke.

Humanoid Flyer

The creature can be any size, but has wings sprouting from its back: pixies, harpies, gargoyles, and pit fiends are examples of humanoid flyer type creatures.

Critical Hits: Use the humanoid charts. Arm hits can

Chapter Nine



strike the wings instead; for frontal attacks roll 1d6; 1–4 means an arm hit, 5–6 a wing hit). Reverse the odds for rear attacks. Arm hits from flank attacks have equal chances of hitting an arm or a wing.

Combat: A flyer's tactics usually emphasize mobility. If the creature has a ranged attack, it stays out of reach and attacks from a distance. In melee, the creature tends to swoop down for flank or rear attacks, then flies out of reach (using the withdraw option at half its flying speed).

Troll/Ape

The creature can be any size, but relies on natural weaponry: trolls, gorillas, and umber hulks are examples of troll/ape type creatures.

Critical Hits: Use the humanoid charts; however, a troll/ape's long arms can be used for locomotion if necessary. Reduce movement penalties from leg hits by one step: a no-move result limits the creature to a $\frac{1}{2}$ move, a $\frac{1}{2}$ -move effect reduces the creature to a $\frac{3}{4}$ move, and a $\frac{3}{4}$ effect is ignored. Trolls and other creatures that regenerate ignore grazes. Points regenerated count as magical healing for reducing bleeding effects. For example, a troll suffers major bleeding for only two rounds before it is reduced to minor bleeding (because it regenerates 6 hit points in that time). After two more rounds, the minor bleeding stops.

Combat: These creatures are fond of overruns (if their size allows) and wrestling attacks (they can bite while wrestling). Their powerful claws are treated as weapons one size larger than normal (see below).

Animal

Animals are creatures with four limbs of some kind and sometimes a tail. They employ natural weaponry and usually walk on four legs, fly, or swim. An animal's size has no effect on its type.

Avian

The creature has two forelimbs adapted for flying (sometimes for swimming) and two hind limbs for walking or roosting: birds, bats, rocs, and perytons are examples of avian type creatures.

Critical Hits: Use the animal charts; treat foreleg hits as wing hits.

Combat: Avians tend to swoop to the attack, then break away, just as humanoid flyers do. Avians attacking from a dive are considered to be charging and inflict double damage with their claws.

Quadruped

This is the most common animal type; examples range from house cats to elephants.

Critical Hits: Use the animal charts. If the animal has no tail, reroll any tail hit.

Combat: Large quadrupeds frequently charge and overrun their opponents. Smaller quadrupeds prefer to attack from surprise.

Serpent

The creature has a head and a long, legless body. Snakes, nagas, and eels are examples of serpent type creatures.

Critical Hits: Use the animal chart; most leg hits are treated as tail hits.

Combat: Many serpents can employ a constriction attack. Treat constriction attacks as wrestling attacks, except that there is no attack of opportunity and the attack must hit the opponent's normal Armor Class. A creature trapped in the serpent's coils is considered grappled and locked (see Chapter Five) and can use the normal wrestling procedure to get free.

Fish/Whale

The creature has a long, streamlined body with flippers or fins for direction control.

Critical Hits: Use the animal charts. Foreleg hits (location rolls of 1 or 2) can affect pectoral fins or flippers. Rolls of 3–5 affect the tail. Movement penalties from fin or flipper hits apply only if the animal changes direction or makes a melee attack during the round. The animal relies on its tail for movement and suffers movement penalties from tail criticals with severities of 9 or more.

Combat: These creatures often employ avian tactics, using their superior swimming speed to deliver quick attacks and then move out of reach.

Monster

Monsters come in all shapes and sizes. The basic monster critical hit charts assume four limbs, a head, and a tail; however, it is often necessary to use two different charts to assign a hit location.

Amorphous

The creature has a fluid body with no obvious limbs; the creature often can alter its shape freely and can form limbs or appendages as needed. Slimes, oozes, jellies, and gelatinous cubes are examples of amor-



Chapter Nine

phous type creatures.

Critical Hits: Amorphous creatures are immune to critical hits.

Combat: Amorphous creatures threaten everything adjacent to them. Fortunately, most of them are nonintelligent and cannot tactically exploit this ability. Amorphous creatures have no flank or rear spaces.

Plant/Fungi

The creature has a fibrous body with no internal skeleton and few or no internal organs. The creature often has vines or branches instead of arms and roots or tendrils instead of legs. Myconids, treants, and shambling mounds are examples of plant/fungi type monsters.

Critical Hits: Use the humanoid critical chart. Abdomen and torso hits affect the trunk or stem. If the creature has no head, head hits affect the trunk instead. Arm hits affect the creature's branches or grasping appendages. Leg hits affect roots (if the roots are exposed) or the trunk. The creature ignores crush results, and all bleeding is automatically reduced by one step.

Combat: Plant/fungi creatures can be very difficult to detect when lurking in normal foliage. When resolving overbearing attempts, the creature gets the bonus for having more than four legs (it's pretty difficult to push a treant down). A plant creature with grasping vines (such as a choke creeper) can make wrestling attacks without provoking an attack of opportunity; such attacks are resolved against the creature's normal Armor Class,

not AC 10. A creature caught in a grasping tendril is considered grappled and locked and can use the normal wrestling procedures to get free.

Dragon

The creature has a scaly body, a head, two or four legs, and a pair of wings sprouting from its back. Dragons, pseudo-dragons, wyverns, and ki-rin are examples of dragon type creatures.

Critical Hits: If the dragon is the same size or smaller than the attacker, use the monster charts. If the dragon has only two legs, foreleg hits strike the wings. If the dragon has four legs, foreleg hits from frontal attacks strike the wings on a roll of 5 or 6 on 1d6. Reverse the odds for rear attacks (wings are struck on a roll 1–4). Foreleg hits from flank attacks have equal chances of hitting an arm or a wing.

If the dragon is one or two sizes larger than the attacker, facing determines the chart to use. Frontal attacks use the humanoid charts, treating foreleg hits as wing hits; leg hits strike the forelegs. Flank attacks use the monster chart, treating foreleg hits as wing hits. Rear attacks use the humanoid chart, treating foreleg hits as wing hits and head hits as tail hits. If the dragon is three or more size classes larger than the attacker, it is immune to special effects from critical hits, though it still suffers double or triple damage.

Combat: Dragons' tactics emphasize mobility. They tend to soften up the opposition with their breath weapons and special attacks before closing to conduct melee. Very large dragons like to overrun spellcasters and other physically weak characters before engaging more formidable characters in physical combat.

Radial

The creature's body is essentially circular, with a central head and torso surrounded by limbs. Octopi, xorns, grell, and beholders are examples of radial type creatures.

Critical Hits: Use the monster charts, treating head hits as torso hits. Any foreleg hit strikes one of the limbs the creature is currently employing in combat. Any tail or hind leg hit strikes a limb not involved in combat. If the creature is employing all its limbs in combat, any leg or tail hit is treated as a foreleg hit. If the creature's limbs have no joints (an octopus's tentacle, for example), the creature ignores movement penalties from knee and hip hits.

Combat: A radial creature with sensory organs on its flank or rear negate the usual bonuses for flank or rear



Monsters



attacks. If the creature also has limbs in its flank or rear sides it threatens those squares, as well. For example, a zorn threatens every square adjacent to it with its three arms and three eyes. An intelligent radial creature might try to grab its opponent's weapons with one or two of its limbs while attacking normally with the rest. Such grab attempts do not provoke attacks of opportunity as long as the creature is making more normal attacks than grab attacks.

Insect/Arachnid

The creature has a chitinous body divided into two or more segments and multiple limbs. Giant insects, giant spiders, giant scorpions, and giant crayfish are examples of insect/arachnid type creatures.

Critical Hits: Use the monster charts. If the creature has no tail, treat tail hits as abdomen hits. Foreleg hits affect the creature's claws or fighting limbs. Hind leg hits affect one of the creature's other limbs. The effected limb is the one closest to the attacker; if several limbs are equidistant, roll randomly to see which limb is effected. The creature's movement is unaffected by damage to the legs as long as it has at least two undamaged legs on each side of its body. For example, a giant spider can suffer knee hits to two of its left legs and suffer no movement penalties. If it suffers damage to a third leg on the left side, however, its movement is affected. All bleeding results are automatically reduced by one step.

Worm

The creature is similar to a snake. It has a long, sinuous body and may or may not have limbs. Giant slugs, giant centipedes, and purple worms are examples of worm type creatures.

Critical Hits: Use the monster charts. Ignore the effects of leg hits unless the creature has hands or claws it can use in combat; in such cases, a forelimb hit (a roll of 1 or 2) strikes the fighting limb. All other leg hits are treated as tail hits.

Combat: Very large worm type creatures often can swallow victims whole. If the creature scores a critical hit, the victim takes double damage and is swallowed whole instead of suffering a special effect.

Centaur

The creature has an animal (usually quadruped) body and a humanoid forepart with a head, torso, abdomen and arms. Centaurs, wemics, and driders are examples of centaur type creatures.

Critical Hits: Use the humanoid charts for frontal attacks. Leg hits affect the creature's animal forelegs and arm hits affect the creature's humanoid arms. Use the monster chart for flank and rear attacks. If the creature has no tail, treat tail hits as abdomen hits.

Combat: Centaur type creatures armed with missiles function as unmounted archers. Some centaurs types might use a weapon to parry, block, or disarm while attacking with their forelimbs.

Merman

The creature has a fish or snake body and humanoid or animal foreparts. Mermen, sea lions, and yuan-ti are examples of merman type creatures.

Critical Hits: Use the humanoid or animal chart for frontal attacks, re-rolling leg hits. Use the monster chart for flank and rear attacks. Foreleg hits strike the creature's arms or forelimbs. Rolls of 3–5 strike the tail. The animal relies on its tail for movement and suffers movement penalties from tail criticals with severities of 9 or more.

Lizard Man/Lycanthrope

The creature has a generally humanoid body shape but also has a tail. Lizard men and lycanthropes in hybrid form are examples of lizard man/lycanthrope type creatures.

Critical Hits: Use the humanoid chart for frontal attacks. Use the monster chart for flank and rear attacks. Forelimb hits strike the creature's arms.

Combat: These creatures generally function as humanoids in combat. Many of them also can bite while attacking with a weapon; bite attacks are made on the creature's base initiative phase and can be made simultaneously with a weapon attack.

Other

The creature defies easy classification. This type includes all creatures that lack large limbs and well-defined body areas, and creatures that are too small to present well-defined target areas. Normal insects, crawling claws, and urchins fall into this category.

Critical Hits: Use the monster chart. Treat all critical hits as abdomen hits.

Combat: These creatures usually employ specialized attack forms based on their unique physical characteristics. Creatures with ranged attacks usually use them in favor of melee attacks.

Chapter Nine

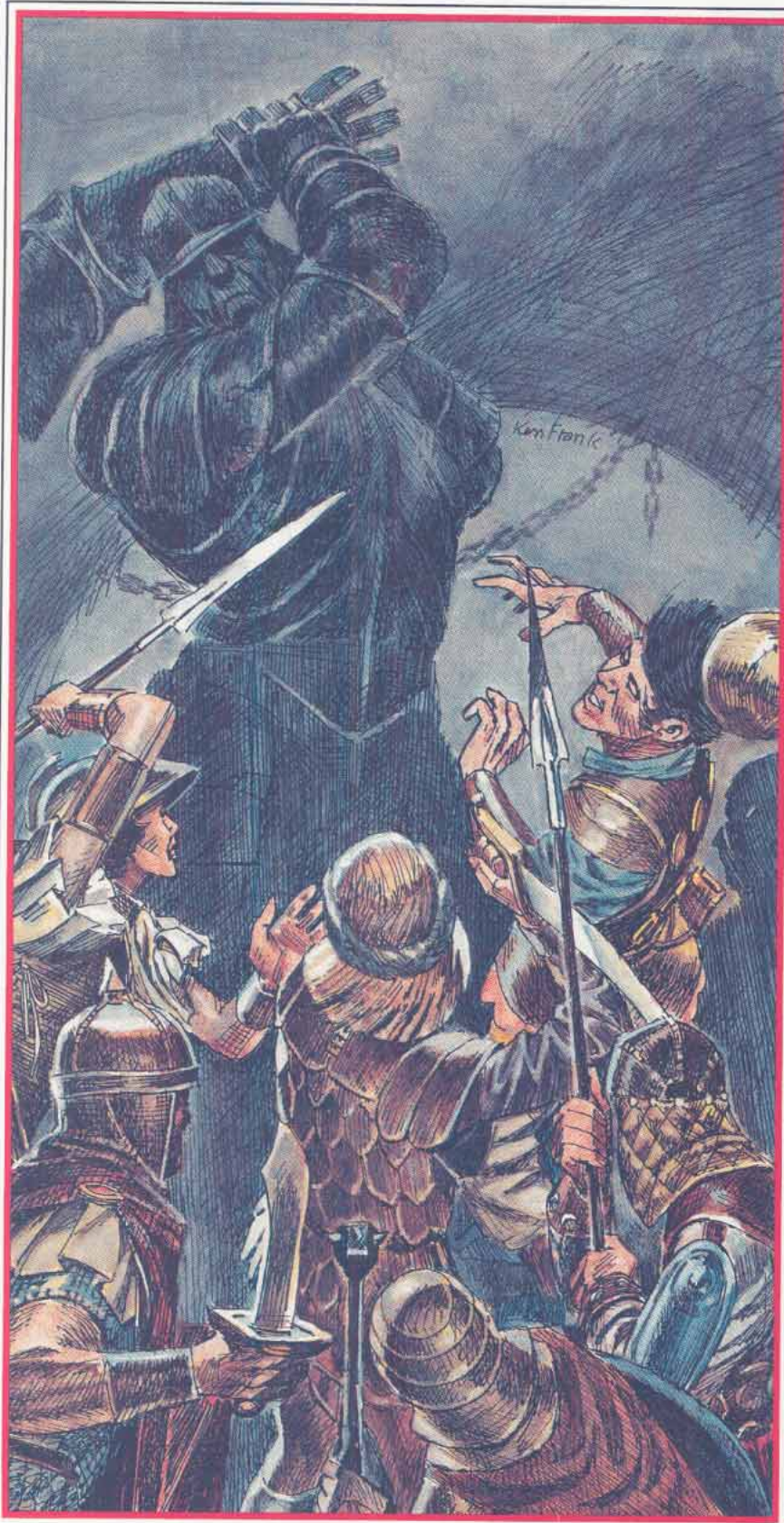

Undead

The creature is dead; it can be an animated or transformed corpse, such as a skeleton, ghoul or vampire, or a physical manifestation of a dead creature's spirit, such as a ghost, wraith, or spectre.

Critical Hits: Use the chart appropriate for the creature's body type; most undead are humanoid. Undead are immune to most critical hits. They completely ignore grazed, struck, and injured results. They suffer only the movement penalties for crushed, shattered, and destroyed results (they ignore attack penalties and hit point reductions). Undead ignore bleeding effects. Incorporeal undead ignore critical hits altogether, but still suffer double damage.

Combat: Most undead eagerly enter melee combat. Mindless undead simply attack. Intelligent undead hope to make full use of their touch-delivered special attacks.

Golem

The creature is an artificial construct or magically animated object. The various golems and most animated objects are examples of golem type creatures.

Critical Hits: Use the chart appropriate for the creature's body type; most golems are humanoid. Golems are hard to hurt; reduce all severity rolls by two (treat results of 0 or less as no effect). They completely ignore grazed, struck, and injured results. They are immune to bleeding. They suffer only the movement penalties for crushed, shattered, and destroyed results (they ignore attack penalties and hit point reductions).

Combat: Most golems are mindless. If left on their own, they move directly into melee, attacking whatever creatures they can reach. Golems under another creature's direction might employ more sophis-

Monsters



ticated tactics, depending on the directing creature's ability to formulate plans and communicate them effectively.

Attack and Armor Types

help it resist attacks just as magical armor or a high Dexterity score does.

A monster's claws and teeth can inflict critical hits just as a normal weapon can. A monster's natural defenses also

Attacks

To determine the type and severity of a critical hit inflicted by a monster, consult the table below:

Form	Type	Size
Bite	P/S*	Same as Creature
Butt	B	Same as Creature
Claw	S	Creature -1**
Fist	B	Creature -1
Horn	P	Same as Creature
Hoof	B	Creature -1
Tail	B	Same as Creature
Sting	P	Creature -1
Wing	B	Same as Creature

Form: What the creature uses to deliver the attack.

Type: The kind of attack the creatures delivers. The three categories are the same as the categories for weapons—piercing (P), bludgeoning (B), and slashing (S).

Size: How large the weapon is for purposes of determining severity. Creature -1 means the attack is treated as one size class lower than the creature. For example, a claw attack from a bulette is treated as a Medium weapon for purposes of critical severity.

*Treat as a slashing attack unless the target is immune to slashing weapons or only the creature's fangs are large enough to inflict damage. For example, snake and spider bites are piercing attacks.

**Claw attacks from troll/ape type creatures are treated as the same size class as the creature for severity purposes.

Armor

A creature subjected to an attack that ignores armor, such as an overbearing attempt, a short-range shot from a crossbow, or a shot from a bombardment engine, might be entitled to an adjustment to its effective Armor Class of 10 due to Dexterity or magic.

Divide a creature's land movement rate by 9 or its flying or swimming movement rate by 12 to get its effective Dexterity bonus against such attacks. Drop fractions. If the creature is entitled to multiple Dexterity bonuses, it gets only the best one. For example, a light horse, MV 24, is entitled to a -2 Armor Class adjustment.

Any creature with an Armor Class of less than 0 is entitled to a magical Armor Class adjustment equal to its negative Armor Class. For example, a great wyrm red dragon has an Armor Class of -11. Its effective AC against a short-range crossbow shot or wrestling attack is -3 (there is a -11 magical adjustment and a -2 Dexterity adjustment).

For example, an aarakocra is a human-type creature. It uses the humanoid critical hit charts. Arm hits with a severity of 8 or more also make flying impossible and force a crash landing if the aarakocra is in flight. An aarakocra attacks with two claws, which are treated as small slashing weapons. The creature has an effective -3 Dexterity adjustment to Armor Class due to its flying speed.

A beholder is a radial type creature. It uses the monster critical hit charts. Generally, opponents must attack the creature's central body and must make called shots to affect the creature's eyestalks and central eye. However, foreleg/wing and hind leg critical hits strike the creature's eyestalks and head critical hits affect the creature's central eye. The creature's bite is treated as a size M slashing and piercing attack.

An adult copper dragon is a dragon-type creature. Frontal and rear attacks use the humanoid critical hit tables; flank attacks use the monster critical hit table. Because the dragon is Gargantuan, it is immune to special effects from critical hits inflicted by size M and smaller attacks. The dragon's bite is treated as a Gargantuan slashing/piercing attack. The dragon's claws and kicks are treated as Huge slashing attacks. The dragon's tail slap and wing buffets are treated as Gargantuan blunt attacks. The dragon has a combined magical and Dexterity adjustment to its AC of -5, -2 due to its flying movement rate and -3 due to its standard Armor Class.



Index



- A**
- Abatis166
 - Ability bonuses with weapons146
 - Aborting an action23
 - Action phase17
 - base18
 - effects of moving on27
 - encumbrance's effect on18
 - in dueling51
 - movement's effect on21–22
 - of combat17
 - of magical items27
 - of movement18
 - of psionics24
 - of spells24
 - of unarmed attacks27
 - of weapons17
 - weapon speed's effect on18
 - AD&D Rules, standard and optional29
 - Adze129
 - Aerial combat66–67
 - Air walk*69
 - Alertness78
 - Alignment of creatures180
 - Ambidexterity78
 - Ambush78
 - Ancient cultures' weapons118–119
 - Ankus129
 - Apparatus of Kwalish*69
 - Approach of a castle168
 - Archery from horseback41
 - Armor127
 - weapon types vs.31
 - Armor Class,
 - benefits due to a shield wall39
 - bonus due to
 - sitting or lying prone30
 - by shield type72
 - effects of parrying on27
 - effects of running or sprinting on27
 - water's effect on66
 - while climbing66
 - Armor damage due to critical hits106
 - Armor, descriptions146
 - proficiency72
 - tables128
 - creatures' types187
 - Artillerist177
 - Assistance in wrestling88
 - Astral combat67
 - Attack options42
 - with unarmed attacks93
 - Attack penalties from critical hits106
 - Attack types for creatures187
 - Attacking20, 24
 - Attacks of opportunity13
 - and missile fire25
 - and retreats28
 - and withdrawing27
 - during overruns22
 - free adjustment's effect on20
 - limits to13
 - vs. grabs44
 - vs. overbears44
 - vs. sapping46
 - vs. unarmed attacks27, 47, 83
 - Attacks per round75
 - with specialization75
 - Axe, battle129
 - stone129
 - two handed145

B

 - Backward kick98
 - Back-and-breast armor147
 - Badianis as battlefields58
 - Bagh nakh129
 - Ballista154
 - Banded mail147
 - Barding150
 - Barred weapons71–72
 - Base initiative18
 - Battering ram165
 - Battle axe129
 - Battle maps7
 - Battle tactics39
 - Battlefields57
 - effects of magic on68
 - setup16
 - Battlements168
 - Belaying pin129
 - Belfry167
 - Bigby's clenched fist*171
 - Bleeding105
 - Blink*68
 - Blocking42
 - as an unarmed attack93
 - in dueling53
 - Blowgun129
 - Bo stick134
 - Bogs in a battlefield64
 - Bolas134
 - Bombard154
 - Bombardment engines153
 - Bone armor150
 - Boomerang134
 - Boots of speed69
 - Boots of striding and springing*69
 - Bore165
 - Bottle134
 - Bow134
 - Bow specialization74
 - Brandistock134
 - Brawling83
 - Breaking free of wrestling holds88
 - Brigandine armor147
 - Broad weapon groups71
 - Broken bones104
 - Broken topography in a battlefield64
 - Bronze Age weapons118
 - Bronze plate mail147
 - Buckler shield147
 - Buildings as battlefields57
 - Burning materials169

C

 - Called shot42
 - as an unarmed attack93
 - location in critical hits103
 - Caltrop134
 - Camouflage79
 - Cannon154, 160
 - Cap147
 - Carrying capacities for beasts163
 - Casting spells20, 24
 - from chariots162
 - from wagons164
 - Castles as battlefields57
 - Catapult155
 - Catwalks168
 - Cauldron165
 - Caves as battlefields57, 59
 - Cestus135
 - in pummeling84
 - Chain135
 - Chain barding150
 - Chain hauberk147
 - Chain mail armor147
 - Chain-lamellar armor147
 - Chakram135
 - Characters and morale29
 - Charging24–25
 - vs. a spear or pike hedge39
 - as a result of running or sprinting27
 - mounted40
 - vs. guarding25, 26
 - Chanot160
 - Chjikin135
 - Choosing a combat action23
 - Classes and weapon proficiencies71
 - Clear figures10–11
 - Clear ground in a battlefield64
 - Clear lines of fire58
 - Clear terrain in a battlefield64
 - Climbing66
 - Climbing check66
 - Climbing walls168
 - Close attack in dueling54
 - Close order7
 - as part of a shield wall39
 - as part of a spear or pike hedge39
 - Close-faced helm147
 - Club135
 - great135
 - war145
 - Combat, action phases17
 - adjustments for a spear or pike hedge39
 - against flying creatures66
 - astral67
 - bonus due to higher ground31
 - bonus for mounted charge40
 - dueling51
 - effects of encumbrance15
 - ethereal68
 - five basic steps of16–17
 - from chariots162
 - from wagons164
 - heroic frays54
 - in unusual conditions65
 - local fighting styles78
 - martial arts95
 - rear and flank attacks30
 - subdual attacks94
 - unarmed27
 - unarmed attack options93
 - vs. a shield wall39
 - vs. sitting or prone creatures30
 - water's effects on65
 - while climbing66
 - Combat actions19–20
 - aborting23
 - choosing23
 - effect on action phase17
 - effects on movement20
 - in conjunction with movement22
 - Combat on other planes67
 - Combat round10
 - Combined scale10
 - Common materials118
 - Concealment30
 - on the battlefield58
 - Constitution bonus to fatigue28
 - Cord armor147
 - Cost of weapons117
 - Counter mining174
 - Cover30
 - on the battlefield58
 - Covering20, 25
 - Creature size, in shield walls39
 - knockdown number32
 - and two-handed weapons49
 - Creature types181–186
 - Creatures in battle179
 - Critical events18
 - in dueling51
 - Critical hits32, 101
 - charts102
 - effects105
 - from covering25
 - from pummeling84
 - from wrestling87, 88
 - resulting from a called shot43
 - with a *sword of sharpness or vorpal sword*69
 - with direct fire engines160
 - with indirect fire engines157
 - with rocks166
 - Crossbow135
 - specialization74
 - Crossbow of accuracy*69
 - Crusades' weapons120–123
 - Crushed, shattered, or destroyed limbs104
 - Crushing blow98
 - Curtain walls168

D

 - Dagger135
 - Damage31
 - of weapons129
 - Dark Ages' weapons120–121
 - Darkness's effects on visibility65
 - Darkness, 15' radius*168
 - Dart136

Index

Death	31
Defensive disarm	43
Deserts as battlefields	59
Destroyed limbs	104
Destroyed targets	171
<i>Dig</i>	171
Direct fire engines	159
Dirty fighting	79
Disarming	43
as an unarmed attack	93
in dueling	53, 54
<i>Disintegrate</i>	171
Doors	169
Driving checks	164
Dueling	51
with unarmed attacks	93
Dueling plot	51–52
Dungeons as battlefields	57
Duration of spells	10
Dying	31

E

Earth rampsarts	168
<i>Earthquake</i>	171
Embrasure shutters	168
Encounter range	16, 57
in astral combat	67
in ethereal combat	68
Encumbrance	14–15
effects on combat	15
effects on initiative and action phase	18
fatigue's effects on	28
in ethereal combat	68
End of the combat round	28
Endurance	79
<i>Enlarge</i>	68
Equipment groups	117
Escalades	168
Escarments	64
Ethereal combat	68
Exceptional abilities	
effects on movement	14
Exhausted characters	28
Expertise	74
in martial arts	96
in pummeling	85
in wrestling	89
Extreme range	75–76

F

Facing, and shield use	72
during movement	22
free adjustment	20, 22
front, flank, and rear	7
multiple figures in the same square	7
Failing a morale check	29
Familiarity	73
in martial arts	95
in pummeling	84
in wrestling	89
Farmland as battlefields	59
Fatigue	17, 28
and force marching	29
effects of running or sprinting on	27
Fatigued characters	28
Fainting in dueling	54
Field plate armor	148
Fields as battlefields	59
Fighting, while climbing	66
flying creatures	66
in unusual conditions	65
Fighting style specializations	76
Fighting styles	49
Figures, clear	10–11
facing of	7
grappled	10, 12
threatened	10–11
Fine balance	79
Firearms	126–127, 136
from horseback	41
in missile-weapon fighting style	50
specialization	75
<i>Fireball</i>	171

Fires	169
Firing into a melee	31
Firing missiles	20, 25
at mounts	41
at sitting or prone creatures	30
from chariots	162
from horseback	41
from wagons	164
in ethereal combat	68
into a melee	31
into the water	65
rocks	167
vs. a shield wall	39
Flail	137
Flaming projectiles with direct fire engines	160
Flaming projectiles with indirect fire engines	156
Flank attacks	30
Flat topography in a battlefield	64
Flying kick	98
Fog's effects on visibility	65
<i>Fog cloud</i>	68
Footing, effects on movement	30
on the battlefield	58
Footman's mace	139
Footman's pick	141
Force marching's effects on fatigue	29
Forest, heavy, as battlefields	59
Forest, light, as battlefields	60
Fork	137
Formal morale checks	29
Fortifications as battlefields	57
Free adjustment during a no-move action	20, 22
Fresh characters	28
Full plate armor	148
Full-move actions	20

G

Gaff/hook	138
Gallery shed	166
Gallic armor	148
Gargantuan creatures, number per square	7
Gates	171
Generating a battlefield	62
Grab	44
Grand mastery	76
Grappled figures	10, 12
Grappling	138
as overbearing	91
as wrestling	87
Grappling hooks	169
Gray areas	32
Grazes	104
Great club	135
Great helm	148
Greek fire	169
projector	166
Ground cover in a battlefield	64
Guarding	20, 26
in a spear or pike hedge	39
vs. charging	25
Gunsen	138

H

Half-move actions	20
Half-plate armor	148
<i>Hallucinatory terrain</i>	68
Hammer	89, 138
sledge	143
Hand or throwing axe	138
Harpoon	138
<i>Haste</i>	68
Hatchet	138
Hazards on the battlefield	58
Helm, great	148
leather	148
open-faced	149
Heroic frays	54
Hexes on maps	7
Hide armor	148
High attacks in critical hits	103
High mastery	75
Higher ground	31
Hills as battlefields	60
Hilly topography in a battlefield	64

Hoardings	168
Holds in wrestling	87
Holy symbol	138
Hoplite armor	148
<i>Horn of blasting</i>	171
Horse archery specialization	78
Horseman's mace	139
Horseman's pick	141
Horses performing overruns	22
Howdah	162
Huge creatures, number per square	7
Hundred Years' War's weapons	122–123

I

Impaired lines of fire	58
Improved mail armor	148
Incendiary cloud	172
Indirect fire engines	155
Informal morale checks	29
Initiative	17
base	18
during covering	25
effects of moving on	27
encumbrance's effect on	18
in aerial combat	66
in dueling	51
movement's effect on	21–22
of combat actions	17
of magical items	27
of movement	18
of psionics	24
of spells	24
of unarmed attacks	27
of weapons	17
weapon speed's effect on	18
Injuries	104
Instant stand	98
Intelligence's bonus proficiency slots	71
Intelligence of creatures	179
Investment	175
<i>Invisibility</i>	68
Iron will	79

J

Javelin	138
Jitte	138
<i>Jump</i>	68
Jungle as battlefields	59

K

Kama	138
Kau sin ke	138
Kawanaga	138
Kicking in pummeling	85
Kits and barred weapons	72
Kneeling	30
Knife	138
throwing	144
Knockdown die	31
Knockdowns	31
and pummeling	84
as a result of retreats	28
due to critical hits	106
due to unhorsing	49
from temporary damage	83
from wrestling	88
in overbearing	91
of weapons	129
with direct fire engines	160
with indirect fire engines	156
with rocks	167
Kusan-gama	138

L

Ladders	169, 171
Lamellar armor	148
Lamellar shirt	148
Lance	139
bonus for a mounted charge	40
Lantern	139
Large creatures, number per square	7
Large shield	150
Lasso	139
Leadership	80

Index

- Leather armor148
 Leather helm148
 Leather scale barding150
 Light scale armor148
Lightning bolt172
 Lines of fire30, 58
 against a shield wall39
 Local fighting styles78
 Location of critical hits103
 Locks in wrestling87, 88
 Long spear143
 Lorica hamata armor148
 Lorica segmenta armor148
 Low attacks in critical hits103
 Lying down30
- M**
- Mace, footman's139
 horseman's139
 Mace-axe139
 Machete139
 Magic on the battlefield68
 Magical attacks, structural171
 Magical items, on the battlefield
 use during combat27
 Magical weapons18
 Mahout162
 Mail and plate armor149
 Mail coif149
 Major bleeding105
 Mancatcher140
 Manipulate89
 Mantlet166
 Man-sized creatures, number per square7
 Maps, as battlefields
 battle7
 generating a battlefield62
 movement on22
 using hexes7
 Marsh as battlefields60
 Martial arts27, 95
 talents97
 weapons96
 Mass combat175
 Master weapons list
 tables130–133
 Mastery75
 in martial arts96
 in pummeling85
 in wrestling90
 Materials on the battlefield58
Mattock of the titans172
 Maul140
Maul of the titans172
 Medium shield149
 Melee combatsee *Combat*
 Melee scale8
 Melee weapon specialization74
 Middle Eastern weapons124–126
 Mines174
 Minor bleeding105
 Miscellaneous war machines165
 Missile deflection98
 Missile fire20, 25
 accidental firing due to knockdown32
 against sitting or prone creatures30
 at mounts41
 effects of cover and concealment on30
 from chariots162
 from horseback41
 from wagons164
 in ethereal combat68
 into a melee31
 rocks167
 vs. a shield wall39
 water's effects on65
 Missile range of weapons129
 Missile scale9
 in astral combat67
 Missile weapon specialization74
 Missile- or thrown-weapon fighting style
 specialization78
 Monster types181–186
 Monsters, and fatigue points28
- and unarmed attacks27
 base initiative18
 in battle179
 knockdown chances and immunities32
 range of attacks8
 resistance to critical hits103
 Strength formula14
 threatening squares of72
 with missile attacks25
 Moonlight's effects on visibility65
 Morale17, 29
 of creatures180
 Morningstar140
 Mountains as battlefields60
 Mounted attacks as overruns22
 Mounted charge40
 Mounts30
 unhorsing49
Move earth172
 Movement13
 and footing30
 climbing66
 combat actions' effects on20
 free adjustment20, 22
 in a shield wall39
 in a spear or pike hedge39
 in aenal combat66
 in conjunction with combat actions22
 in dueling53
 on the map22
 penalties due to critical hits106
 under water66
 Movement rate, effects on action phase18
 exceptional abilities' effect on14
 Moving26–27
 Multiple attacks with missile fire25
 Multiple figures and facing7
 Multiple loaded weapons50
- N**
- Natural attacks and knockdowns32
 Negative hit points31
 Net140
 New weapons72
 Nonproficiency72–73
 in martial arts95
 in pummeling84
 in wrestling89
 No-move actions20
 NPCs and morale29
 dueling51
 Number of creatures per square7
 Nunchaku140
- O**
- Obscurement*69
 Obstacles, in generating a battlefield
 on the battlefield58
 Offensive disarm43
 Oil140
 One- or two-handed weapons49
 One-handed weapons used two-handed49
 One-handed-weapon style specialization76
 Open-faced helm149
 Opposed rolls42, 83
 Optional AD&D rules29
 Oriental weapons124–126
 Outside as a battlefield57
 Outside attack in dueling54
 Overbearing27, 44, 91
 a mounted character49
 during overruns23
 Overruns22
 with chariots167
 with wagons164
- P**
- Padded armor149
 Padded barding150
 Palisades, wooden168
 Parang141
 Parrying20, 27
 in dueling53
 Petards171
- Pick141
 footman's141
 horseman's141
 Piercing vs. animals critical hit tables111
 Piercing vs. humanoids critical hit tables110
 Piercing vs. monsters critical hit tables112
 Pike hedge39
 Pilum141
 Pins91–92
 Plains as battlefields61
 Plate and chain barding150
 Plate mail armor149
 bronze147
 Point-blank range74
 Polearm141
 Ponds in a battlefield64
 Portcullises171
Potion of fire breath172
Potion of growth69
Potion of invulnerability69
 Press89
 Priest spells on the battlefield69
 Proficiencies177
 bonus slots due to high intelligence71
 Proficiency74
 in martial arts95
 in pummeling84
 in shield72
 in wrestling89
 Prone30
 Pry bar141
 Psionics's action phase24
 Pulling/Tripping45
 a mount or mounted character49
 as an unarmed attack93
 in dueling54
 Pummeling83–86
 Punching27
Pyrotechnics68
- Q**
- Quarterstaff141
 Quickness80
- R**
- Rain's effects on visibility65
 Ram catcher167
 Ramming164
 Ramparts, earth168
 Ram, battering165
 Range, of weapons8, 129
 of monsters' attacks8
 Ranged weapons and guarding26
 Rate of fire, from horseback41
 of weapons129
 specialization75
 with multiple loaded weapons50
 Rear attacks30
 Recovering from fatigue28
 Reduction173
 Renaissance's weapons122–126
 Resistance to critical hits103
 Retreats17, 28
 Riding proficiency and injured mounts41
 unhorsing49
 Ring mail armor149
Ring of shooting stars172
Ring of the ram172
 Riposte in dueling54
 Rocks167, 171
 Rod, three-piece144
 Roman weapons119–120
 Round, in combat10
 Rules, standard and optional29
 Running27
- S**
- Sai141
 Sang kauw141
 Sap142
 Sapping46
 in dueling54
 in pummeling85
 structural171

Index

Savage cultures' weapons 117–118

Saving throw bonuses due to cover and concealment 30

Saving throws for sieges 173

Scale, combined 10

 in a battlefield 63

 melee 8

 missile 9

 switching 10

Scale armor, light 148

Scale barding 150

 leather 150

Scale in astral combat 67

Scale mail armor 149

Scaling walls 168

Scimitar of speed 69

Scourge 142

Scythe 142

Severed limbs 104

Severely impaired lines of fire 58

Severity of critical hits 103

Shattered limbs 104

Shield, buckler 147

 damage due to critical hits 106

 large 150

 medium 149

 proficiency 72

 small 149

 specialization 76

 wall 39

Shields in weapon-and-shield fighting style 50

 trapping with 47

 types 72

 vs. rear and flank attacks 30

Shield-punch 46

 in dueling 53

Shield-rush 46

Ships as battlefields 61

Shocking grasp 69

Short sword of quickness 69

Shuriken 142

Shutters, embrasure 168

Sickle 142

Siege tower 167

Sieges 173

Single-weapon fighting style 49

Sitting 30

Size of weapons 129

Slam 88

Slashing vs. animals critical hit tables 114

Slashing vs. humanoids critical hit tables 113

Slashing vs. monsters critical hit tables 115

Sledge hammer 143

Sling 143

Slopes 64

Slow 69

Small creatures, number per square 7

Small shield 149

Smashing in dueling 54

Spade 143

Spear 143

 hedge 39

 long 143

Special combat conditions 29

Special talents 78

Special weapon maneuvers 47

Specialization 74

 and weapon groups 71

 in martial arts 96

 in pummeling 85

 in wrestling 89

Specific injuries 103

Speed of weapons 129

Spellcasting 20

 from chariots 162

 from wagons 164

Spells, action phase of 24

 casting during combat 24

 duration of 10

 on the battlefield 68

Splays 168

Splint mail armor 150

Spring 98

Sprinting 27

Staff sling 143

Standard AD&D rules 29

Starlight's effects on visibility 65

Status 17, 29

Steady hand 80

Stone age weapons 117

Stone axe 129

Stone walls 168

Streams in a battlefield 64

Streets as battlefields 62

Strength of monsters 14

Struck limbs 104

Studded leather armor 150

Styles of martial arts 95

Subdual attacks 93

Surprise 15–16

Swamps as battlefields 62

Swimming 66

Sword 143

Sword of sharpness 69

System I critical hits 101

System II critical hits 101

T

Take down 88

Taverns as battlefields 62

Temporary damage 83

Terrain types, badlands 58

 caves 59

 desert 59

 fields or farmland 59

 forest, heavy or jungle 59

 forest, light 60

 hills 60

 marsh 60

 mountains 60

 plains 61

 ships 61

 swamps 62

 town streets 62

 taverns 62

Thickets in a battlefield 64

Threatened creatures, firing or throwing missiles at 31

Threatened figures 10–11

Threatening, and guarding 26

 and missile fire 25

 and withdrawing 27

 in aerial combat 66

 in astral combat 67

 movement into 22

 vs. unarmed attacks 27

Threatening creatures, firing or throwing missiles at 31

Three-piece rod 144

Three-quarter plate armor 150

Throw 88

Throwing knife 144

Throwing missiles 20, 25

Throwing or hand axe 138

Thrown weapons 50

Thrown-weapon fighting style 50

 specialization 78

Tight weapon groups 71

Tools 118

Topography in a battlefield 63

Torch 145

Town streets as battlefields 62

Towns as battlefields 57

Trampling 22

Transmute rock to mud 172

Trap and break 47

Trapping 47

 in dueling 53

Trebuchet 155

Trident 145

Tripping 45

 a mount 49

 as an unarmed attack 93

 in dueling 54

Trouble sense 80

Two-handed axe 145

Two-handed-weapon fighting style 49

 specialization 77

Two-weapon fighting style 50

 specialization 77

Type of weapons 129

U

Unarmed attack 47

Unarmed combat 27

Unarmed fighting style 58

Unconscious creatures 3

 from pummeling 84

Unhorsing 49

 as an unarmed attack 93

Unseating a rider in aerial combat 67

Use a magical item 27

V

Vehicle handling 177

Vehicles 160

Vial 145

Visibility 65

Vision, in ethereal combat 68

 under water 65

Vorpal sword 69

W

Wagon 163

Wall defenses 168

Wall of fire 173

Wall of iron 173

Wall of stone 173

Walls 168–169

War club 145

War engines' attack and defense values 170

War machines 153

 costs and weights 167

 miscellaneous 165

 vs. other war machines 169

Warhammer 145

Warp wood 173

Water's effects on combat 65

Water in a battlefield 64

Weapon, descriptions 129

 expertise 74

 familiarity 73

 grand mastery 76

 group proficiency 71

 groups 71, 145

 maneuvers 47

 mastery 72, 75

 nonproficiency 72–73

 proficiency 74

 range 8

 restrictions in water 65

 specialization 74

 speed 18

 speed's effect on action phase 17

 vs. target size for critical hits 103

Weapons, and ability bonuses 146

 knockdown die 31

 magical 18

 martial arts 96

 names 117

 new 72

 tables 130–133

 trapping with 47

 used in a shield wall 39

 vs. armor types 31

Weapon-and-shield fighting style 50

 specialization 76

Weapon-specific styles 50

Weight of weapons 129

Whip 145

Wild swing in dueling 54

Withdrawing 27

Wizard spells on the battlefield 68

Wood armor 150

Wooden palisades 168

Woods, heavy, in a battlefield 64

 light, in a battlefield 64

Wounds, binding 31

Wrestler vs. wrestler 85

Wrestling 27, 47, 85

PLAYER'S OPTION™: Combat & Tactics

Advanced Dungeons & Dragons® Rulebook

Tired of your fighter doing nothing but trading swings with monsters? Are your dungeon denizens' tactics getting a little too routine? Need help setting up that siege of the evil overlord's castle? Then this is the book for you. This exciting expansion to the AD&D® game contains rules and systems that will make your battles more vibrant and realistic. There are new rules covering critical hits, tactical options, and combat maneuvers such as shield walls, disarms, and more! Complete weapons tables for all eras of play include lots of new weapons and revised characteristics for old ones. The *Combat & Tactics* system has been carefully designed to present sets of rules in easy-to-use modules that you pick and choose from and incorporate into your campaign. Regardless of which ones you do use, you'll find everything works with everything else.



U.S., CANADA, ASIA,
PACIFIC, & LATIN AMERICA
Wizards of the Coast, Inc.
P.O. Box 707
Renton, WA 98057-0707
+1-206-624-0933



EUROPEAN HEADQUARTERS
Wizards of the Coast, Belgium
P.B. 34
2300 Turnhout
Belgium
+32-14-44-30-44

Visit our website at www.tsr.com

Sug. Retail

\$20.00 US

\$26.00 CAN

©1995 TSR, Inc. All Rights Reserved. Printed in the U.S.A.

ADVANCED DUNGEONS & DRAGONS and AD&D

are registered trademarks owned by TSR, Inc.

PLAYER'S OPTION and the TSR logo are trademarks owned by TSR, Inc.

ISBN 0-7869-0096-2



52000>



9 780786 900961